



NOTICE DE MONTAGE ATTELAGE

OPEL ASTRA 3

N° CE : e11*94/20*5293*00



BOISNIER SAS

REF.: 06174

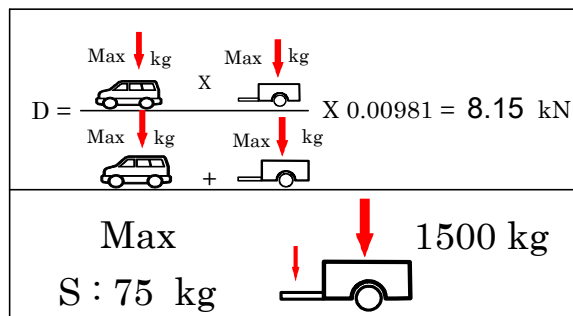

REF.: 06174

Démontage pare chocs :
Trous à réaliser :

NON
OUI

Découpe :

NON
NON

Découpe visible :





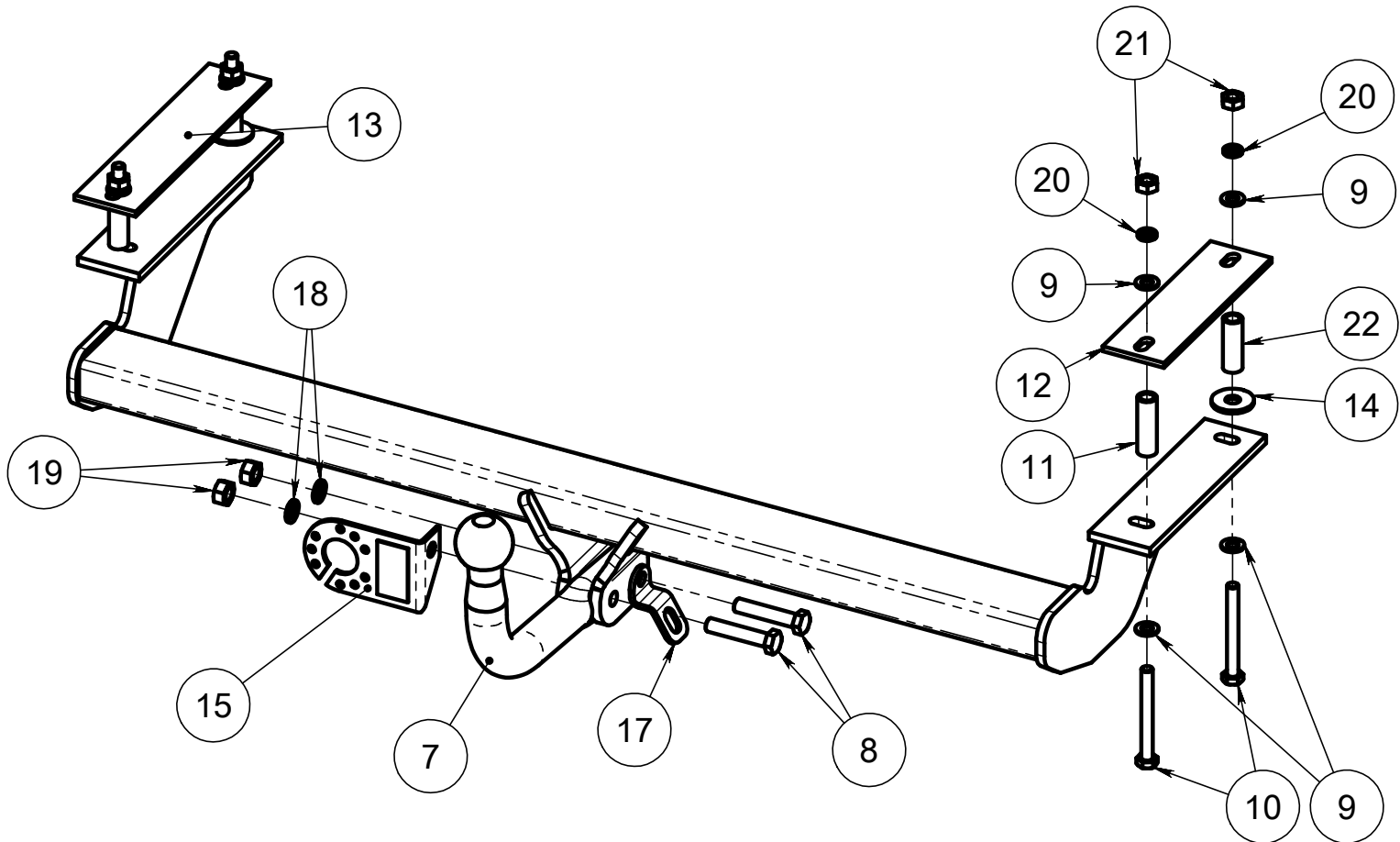





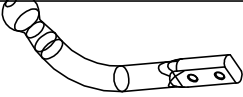
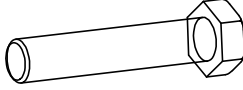
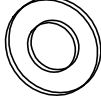
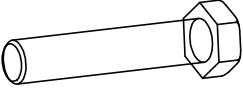

- Décrocher les silentblochs arrière du pot d'échappement.
- Déposer le carter central plastique dans le coffre (clips verticaux et horizontaux).
- A gauche, enlever la garniture prédécoupée collée sur le fond.
- Percer à Ø 17.5 les 4 trous pré-pointés (que sur la face supérieure des longerons).
- Positionner l'attelage et le fixer depuis les trous existants sous les longerons avec la visserie fournie conformément au schéma ci contre.
- Bloquer toute la visserie (voir tableau des couples de serrage).
- Passer et raccorder le faisceau électrique.
- Remonter le carter plastique.

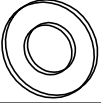
Visserie identique à côté droit

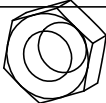

VISSERIE : Diamètre	8	10	12	14	16
Couple de serrage C.L 8.8	2.3	4.5	8.0	13.0	19.0
Couple de serrage C.L 10.9	3.2	6.5	11.0	17.5	27.0

REF.: 06174

Schéma	Rep.	Qté.	DESIGNATION	CODE
	7	1	COL DE CYGNE 260/22	001026
	8	2	vis DIN 931 M12x60 zn	700.00.12060
	9	8	rondelle 10,5x20x2 DIN125A	700.34.10520020
	10	4	vis DIN 931 M10x90 zn	700.00.10090
	11	2	Entretoise 12x17x55	950050
	12	1	RENFORT BRAS DROIT	0617490
	13	1	RENFORT BRAS GAUCHE	0617491
	14	2	rondelle 13x37x3 Din 9021	722.10.13037030
	15	1	SUPPORT PRISE PLIEE	PRISE PLIEE
	17	1	ANNEAU DE SECURITE	958000
	18	2	rondelle GROWER M12 DIN128A zn	700.20.12
	19	2	écrou H DIN 934 M12	700.22.12
	20	4	rondelle GROWER M10 DIN128A zn	700.20.10
	21	4	écrou H DIN 934 M10	700.22.10
	22	2	Entretoise 12x17x50	950048

