

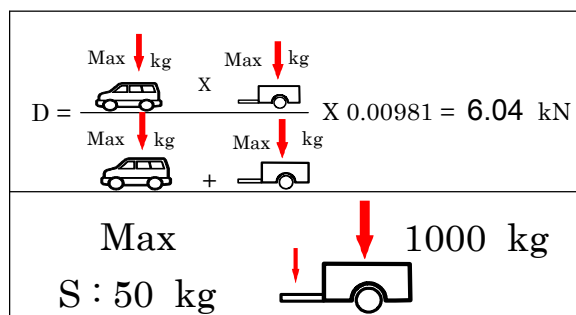

**BOISNIER SAS**

REF.: 06164



REF.: 06164

Démontage pare chocs :  
Trous à réaliser :

OUI
OUI

Découpe :

OUI
-----

Découpe visible :

--





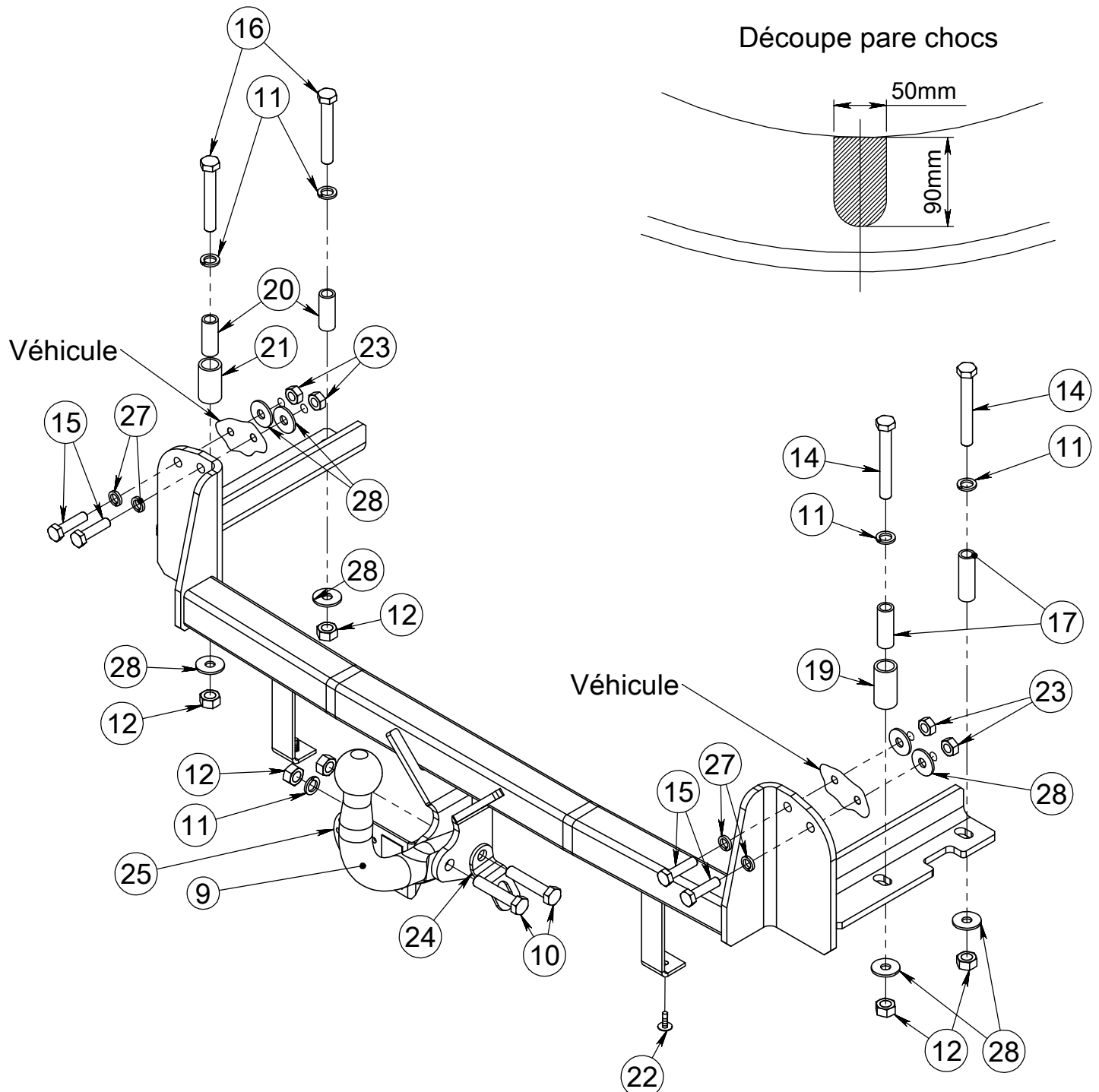
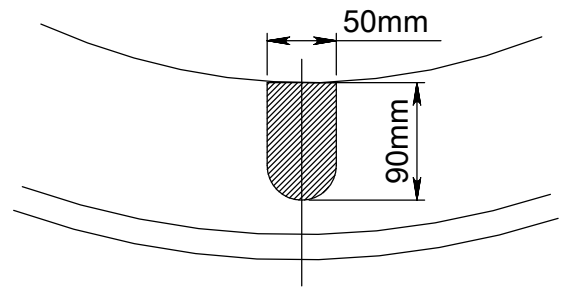





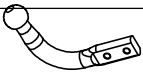
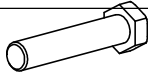



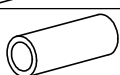

- Déposer le pare chocs (2 clips dessous, 4 écrous sous le joint, 4 écrous sabots des ailes + 2 vis extérieur des ailes)
- Déposer le renfort (ne sera pas remonté), 6 écrous autour des longerons.
- Déposer le tapis de coffre.
- Depuis le coffre percer à Ø 18.2 les trous déjà pointés (uniquement partie supérieure du longeron):  
Coté droit à 120mm du trou existant.  
Coté gauche à 170mm du trou existant.
- Présenter la ferrure et immobiliser avec la visserie fournie conformément au schéma ci contre et percer 4 trous sur la jupe arrière en contreperçant à Ø 11 au niveau des vis M10x40, puis mettre la visserie fournie.
- Découper le pare chocs selon schéma et remonter avec les clips plastique Ø 7.

Découpe pare chocs



OPEL CORSA 3  
DEPUIS 10/2000

REF.: 06164

Schéma	Rep.	Qté.	DESIGNATION	CODE
	9	1	COL DE CYGNE 200/22	001020
	10	2	vis DIN 931 M12x60 zn	700.00.12060
	11	6	rondelle GROWER M12 DIN128A zn	700.20.12
	12	6	écrou H DIN 934 M12	700.22.12
	14	2	vis DIN 931 M12x90 zn	700.00.12090
	15	4	vis EF DIN 933 M10x40 zn	700.03.10040
	16	2	vis DIN 931 M12x80 zn	700.00.12080
	17	1	Entretoise 12x17x47	950047
	18	1	Entretoise 12x17x55	950050
	19	1	Entretoise 18x24x47	950084
	20	2	Entretoise 12x17x42	950045
	21	1	Entretoise 18x24x42	950082
	22	2	CLIPS PLASTIQUE Ø 7	956000
	23	4	écrou H DIN 934 M10	700.22.10
	24	1	ANNEAU DE SECURITE	958000
	25	1	SUPPORT PRISE PLIEE	PRISE PLIEE
	27	4	rondelle GROWER M10 DIN128A zn	700.20.10
	28	8	rondelle 10,5x30x2,5 DIN9021	700.34.10530025

