



NOTICE DE MONTAGE ATTELAGE
CITROEN AX DEPUIS ORIGINE

N° CE : e11*94/20*1674*00



BOISNIER SAS

REF.: 01154

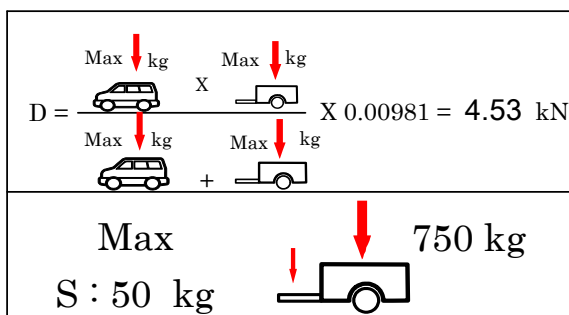

REF.: 01154

Démontage pare chocs :
Trous à réaliser :

NON
OUI

Découpe :
Découpe visible :

NON
NON



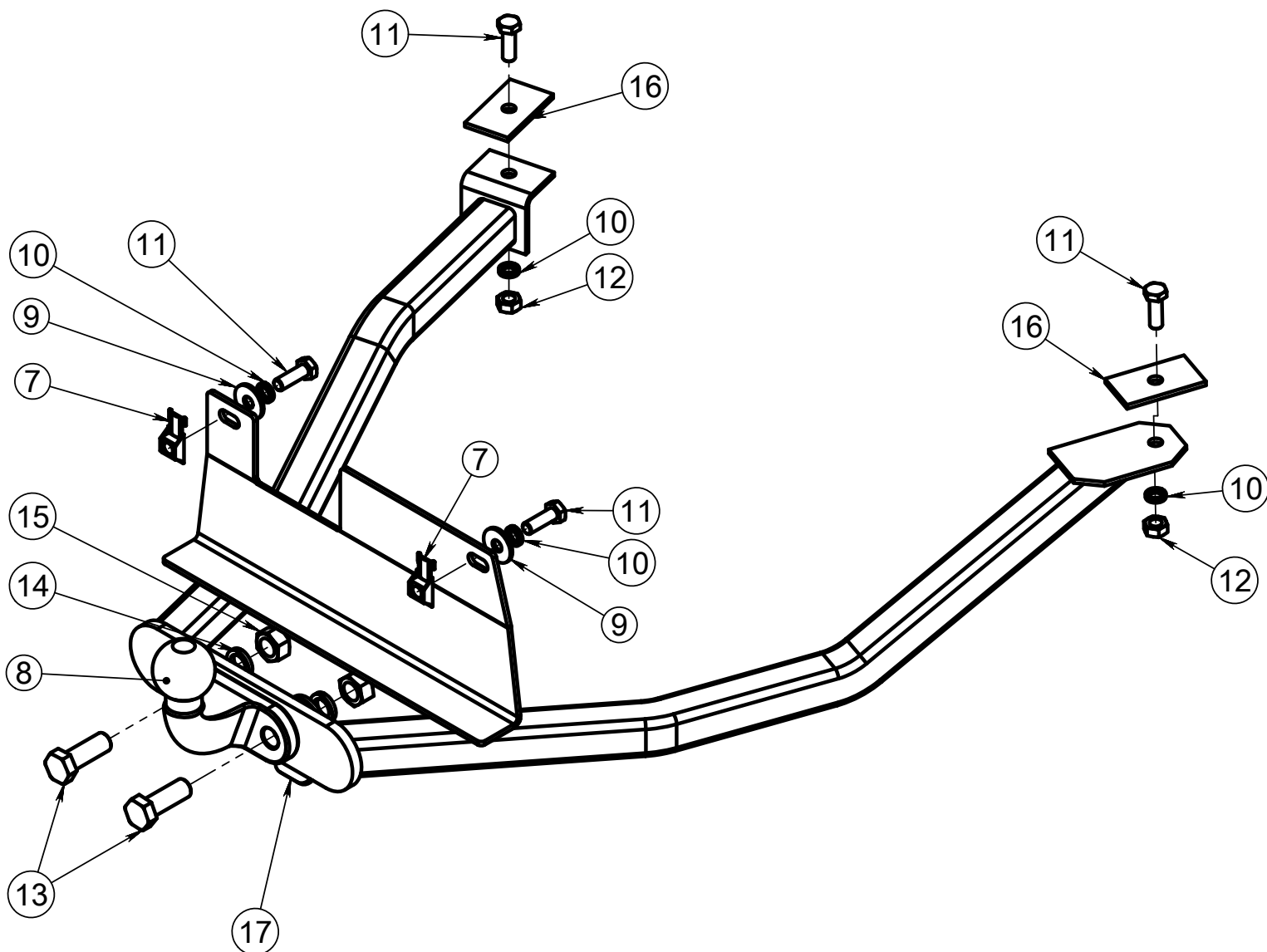





- Mettre en place les écrous cage sur la traverse arrière du véhicule dans les trous existants.
- Introduire la ferrure sous le véhicule et la fixer d'une part à l'aide des vis M10x30 et les écrous cages.
- D'autre part, percer dans le coffre des trous en correspondance au vis M10x30.
- Fixer alors les bras avec les vis M10x30 et les contreplaques.
- Bloquer toute la visserie (voir tableau des couples de serrage).

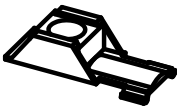
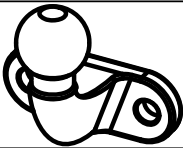

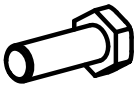
VISSERIE : Diamètre		8	10	12	14	16
Couple de serrage daN.m	C.L 8.8	2.3	4.5	8.0	13.0	19.0
	C.L 10.9	3.2	6.5	11.0	17.5	27.0

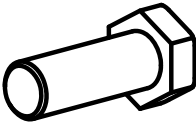
CITROEN AX DEPUIS ORIGINE

REF.: 01154

Schéma	Rep.	Qté.	DESIGNATION	CODE
	7	2	ECROU CAGE M10 44x23	775.00.04
	8	1	REZ 50	REZ 50
	9	2	rondelle 10,5x30x2,5 DIN9021	700.34.10530025
	10	4	rondelle GROWER M10 DIN128A zn	700.20.10
	11	4	vis EF DIN 933 M10x30 zn	700.03.10030
	12	2	écrou H DIN 934 M10	700.22.10
	13	2	vis EF DIN 933 M16x45 zn	700.03.16045
	14	2	rondelle GROWER M16 DIN128A zn	700.20.16
	15	2	écrou H DIN 934 M16	700.22.16
	16	2	Contreplaque D11 40x70x4 zn	952011
	17	1	ANNEAU DE SECURITE	800024

