

**Jaeger FLEX  
2in1**

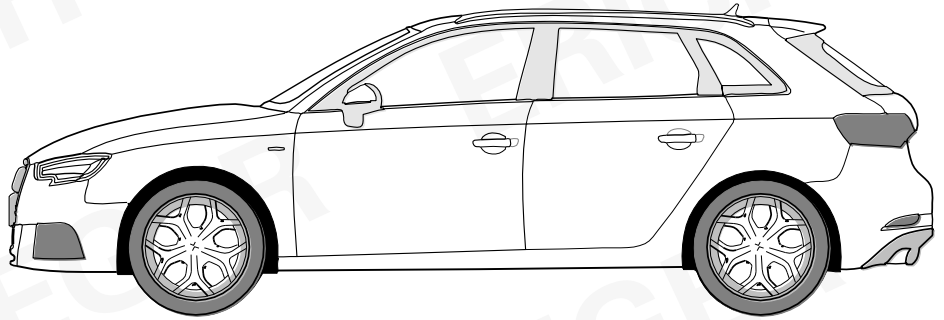

ERICH JAEGER



**AUDI A3**

**07/16 >>**

**748343**

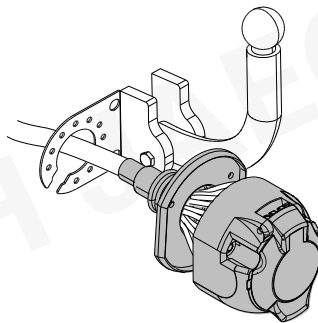

**13-PIN**

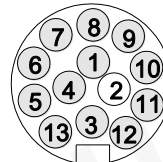

**ISO 11446**

- |  |   |
|--|---|
| <b>(D)</b> Einbauanleitung             | <b>(PL)</b> Instrukcja montażu                |
| <b>(GB)</b> Installation instructions  | <b>(TR)</b> Montaj talimatı                   |
| <b>(F)</b> Consignes de montage        | <b>(H)</b> Beépítési útmutató                 |
| <b>(NL)</b> Montagehandleiding         | <b>(HR)</b> Upute o ugradnji                  |
| <b>(DK)</b> Montagevejledning          | <b>(BUL)</b> Инструкция за монтаж             |
| <b>(N)</b> Monteringsinstruksjon       | <b>(RO)</b> Instrucțiuni de montaj            |
| <b>(S)</b> Installationsanvisning      | <b>(RU)</b> Инструкция по монтажу и установке |
| <b>(FIN)</b> Asennusohje               | <b>(LT)</b> Montavimo informacija             |
| <b>(I)</b> Istruzioni per il montaggio | <b>(LV)</b> Iemontēšanas pamācība             |
| <b>(E)</b> Instrucciones de montaje    | <b>(EST)</b> Paigaldusjuhend                  |
| <b>(P)</b> Instruções de montagem      | <b>(SLO)</b> Navodilo za vgradnjo             |
| <b>(GR)</b> Οδηγίες εγκατάστασης       | <b>(SK)</b> Montážny návod                    |
| <b>(CZ)</b> Návod k montáži            |   |



# KIT

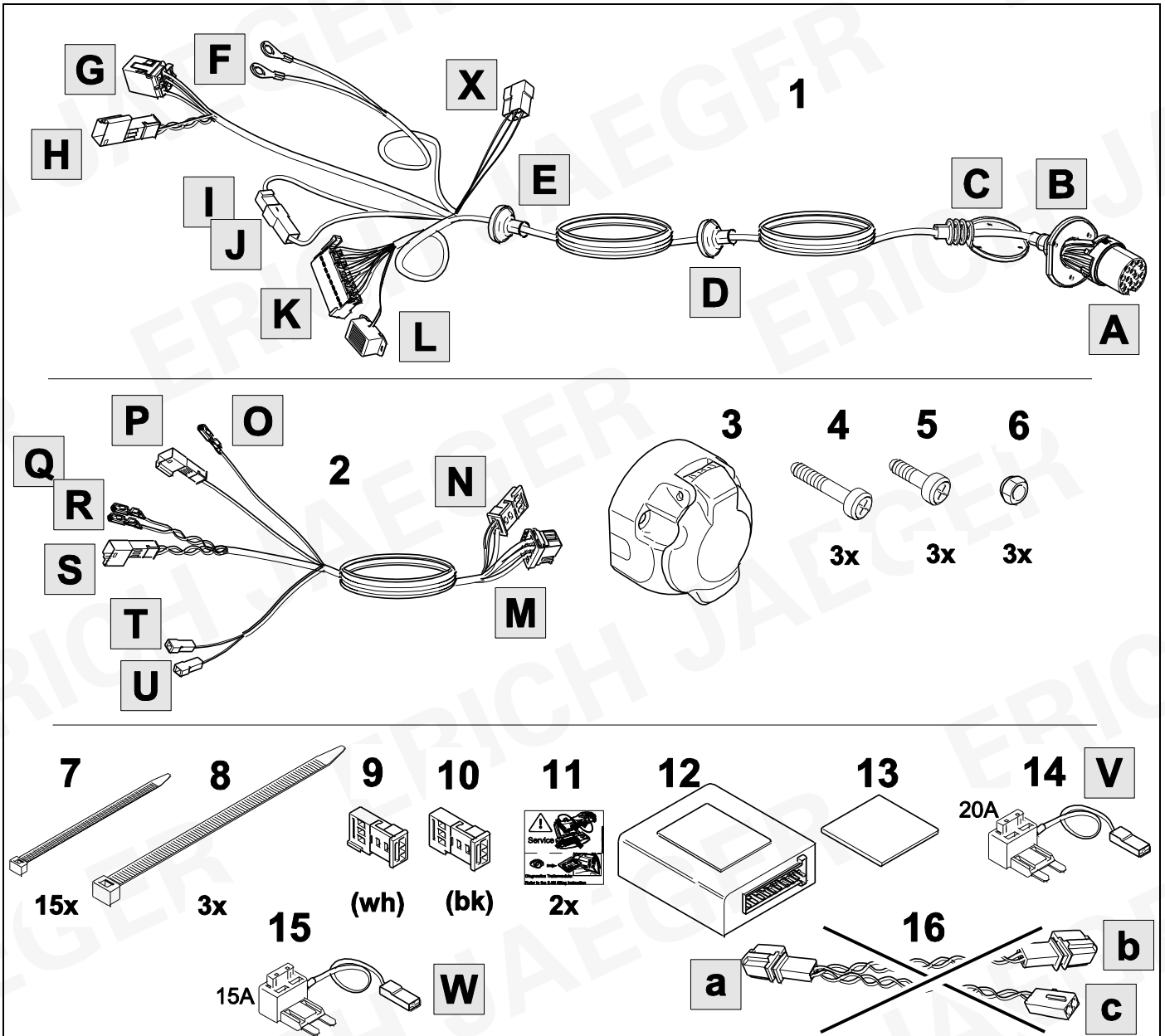

# TOOLS

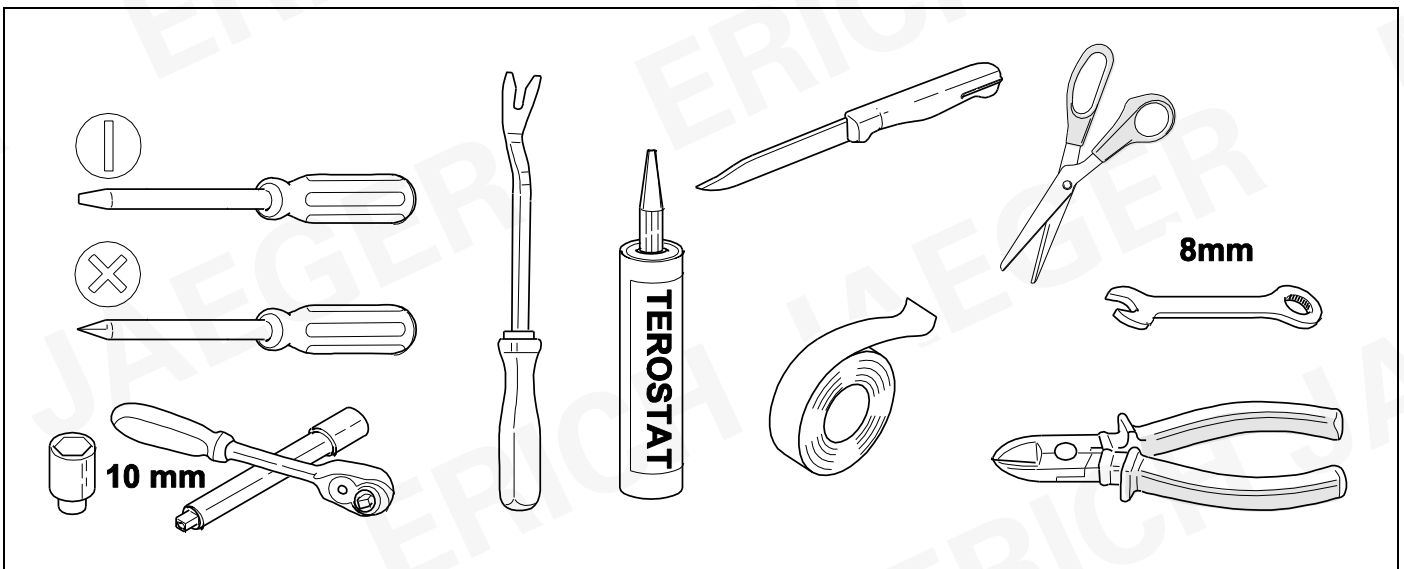

1

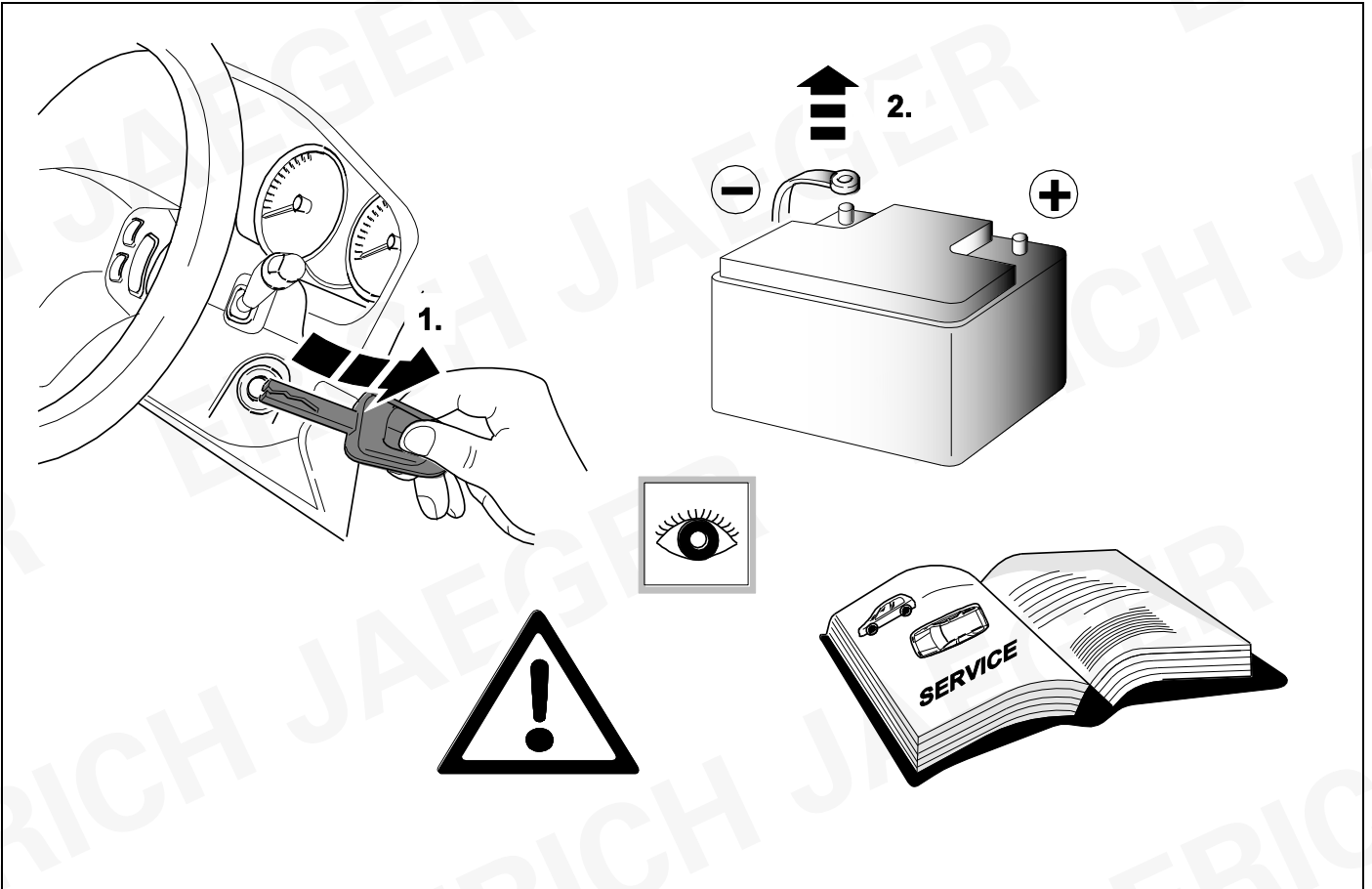

## 2 REMOVE

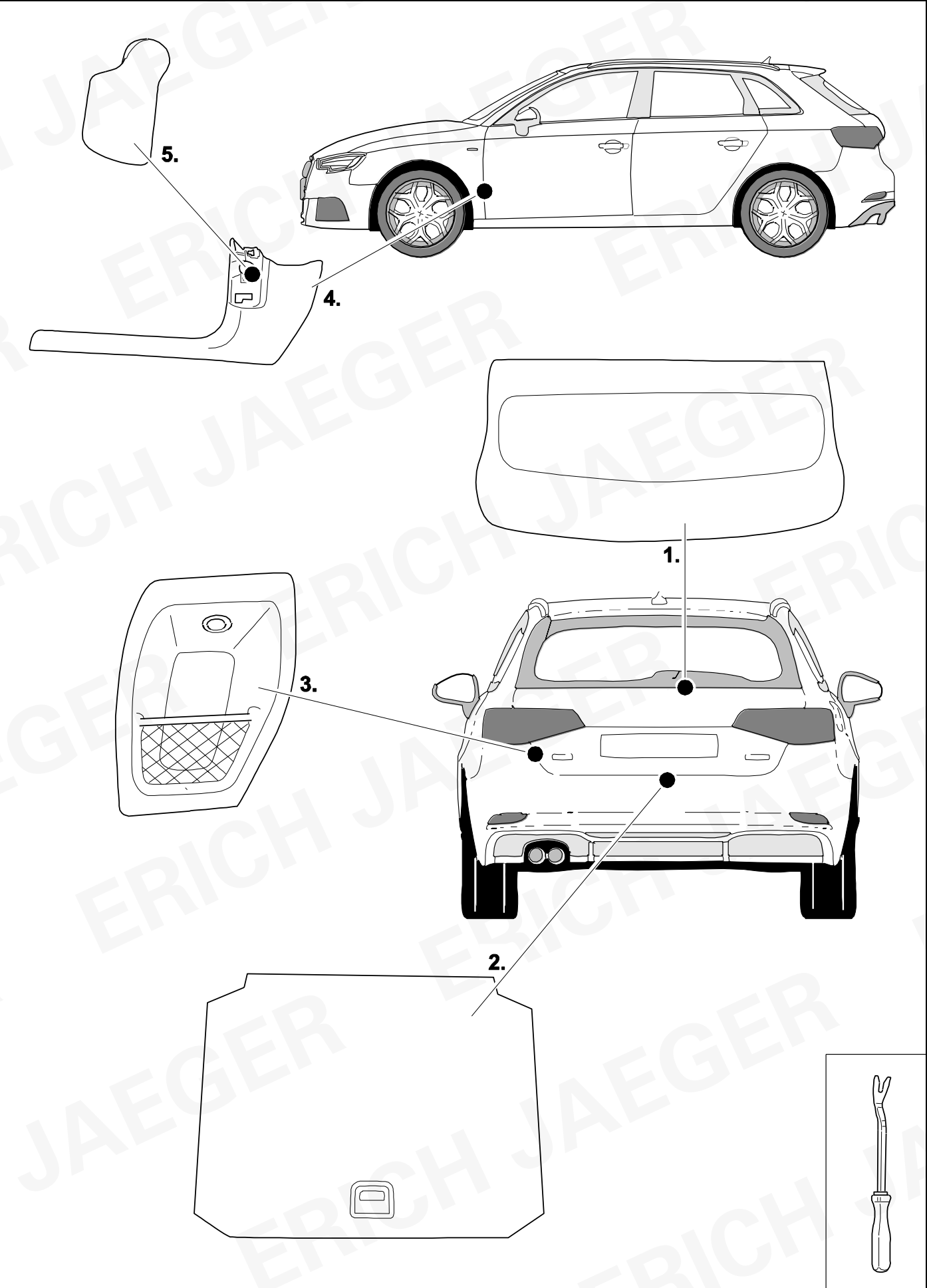

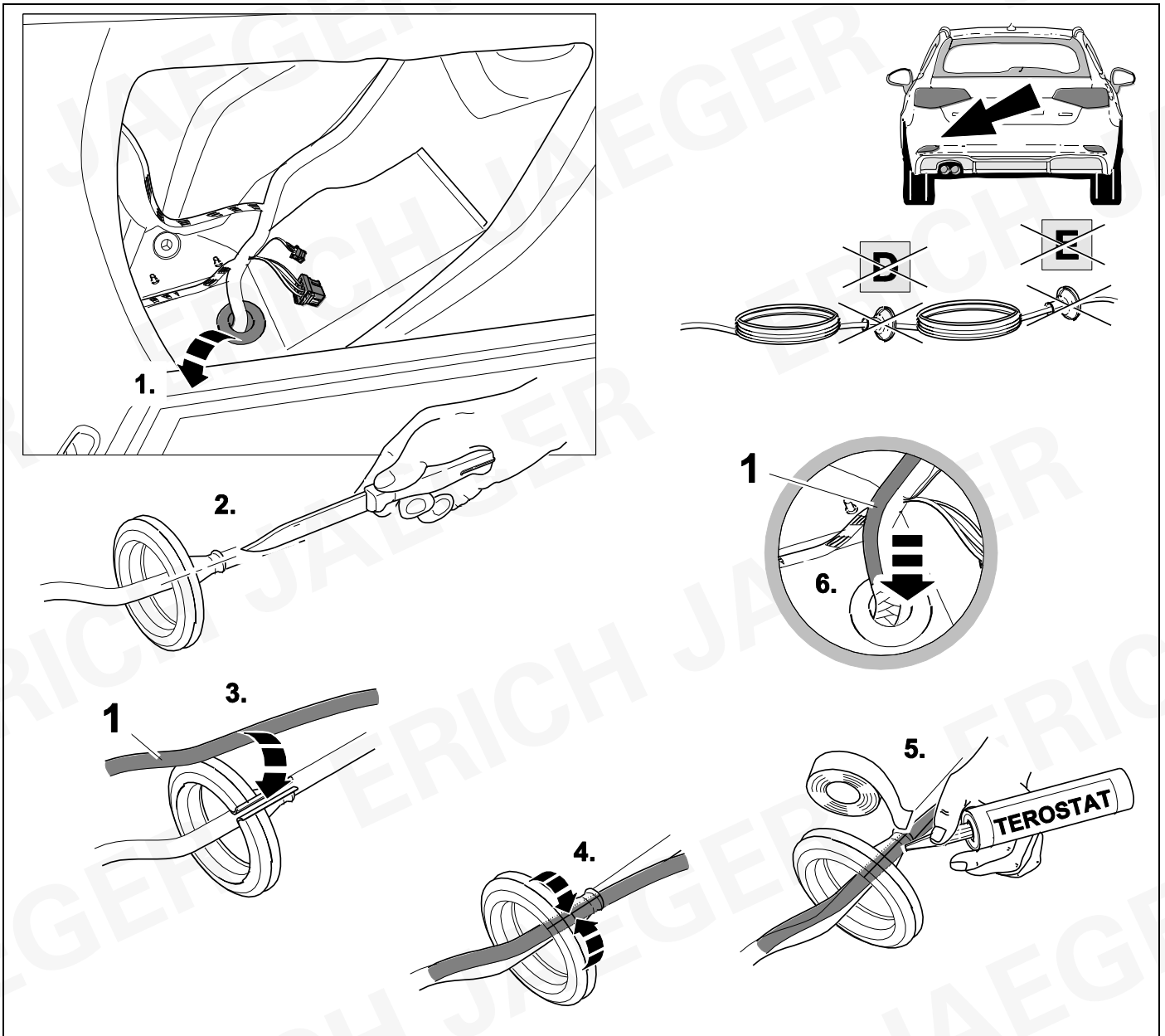

4

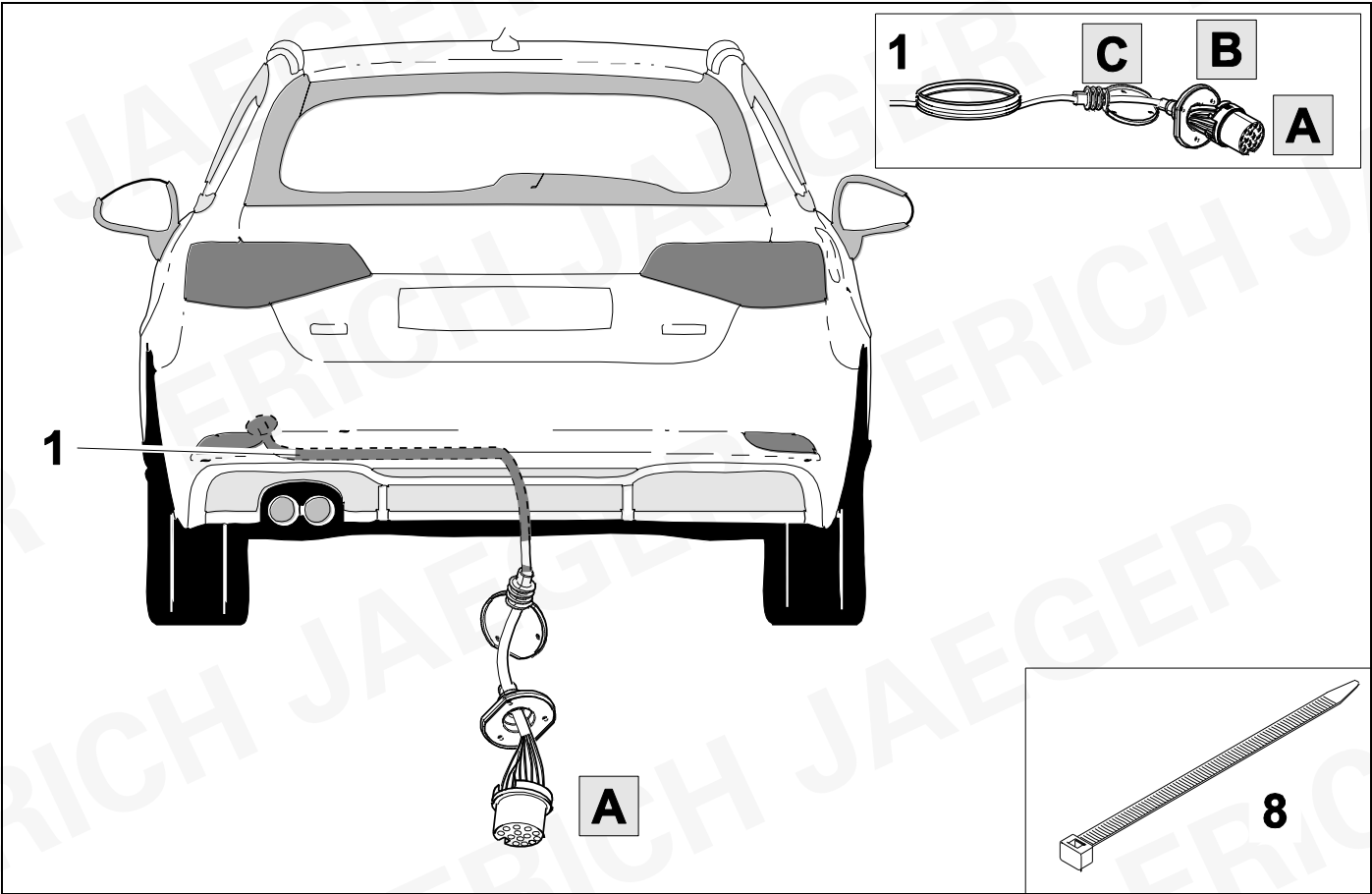

5

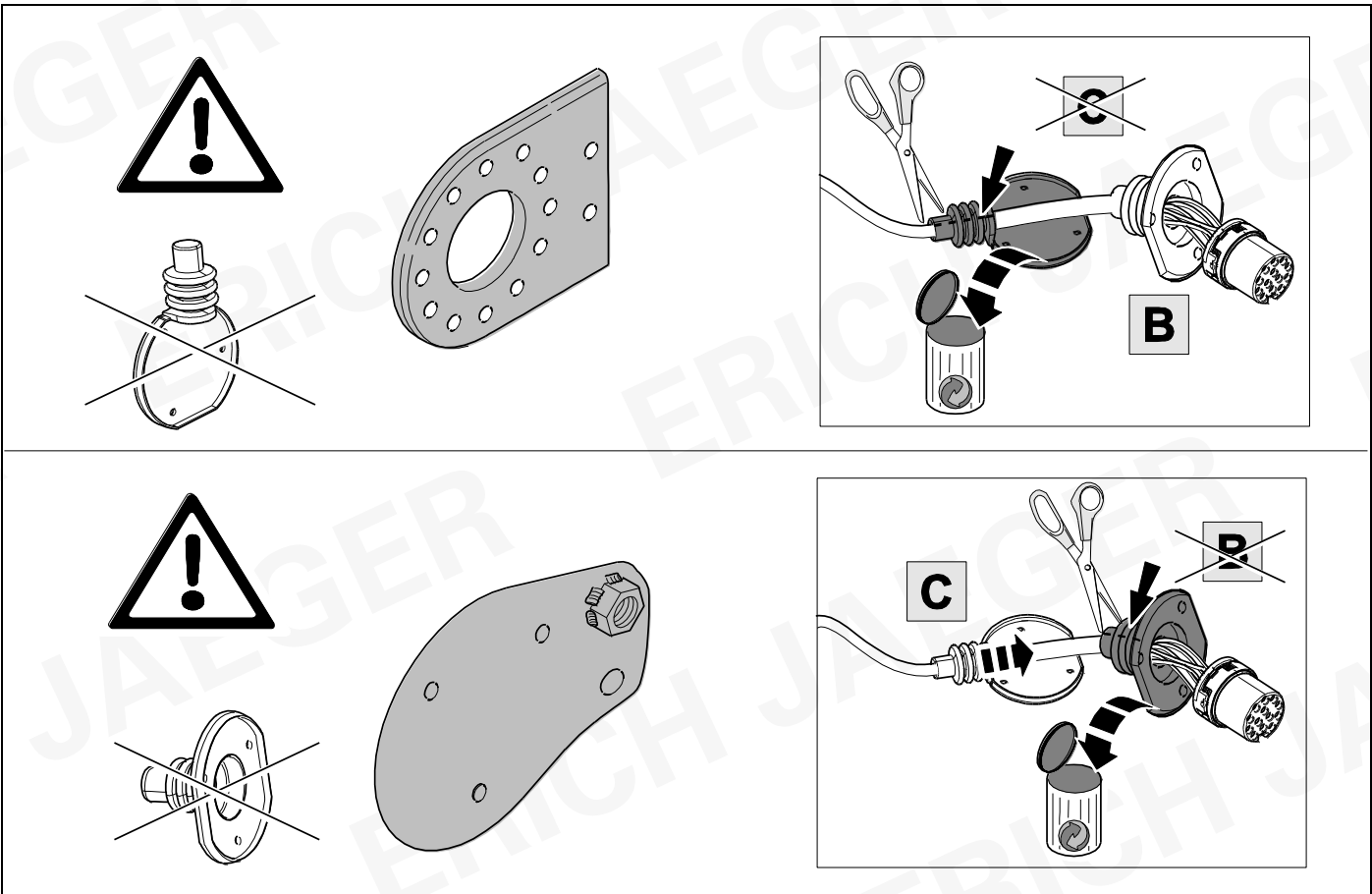

6



8

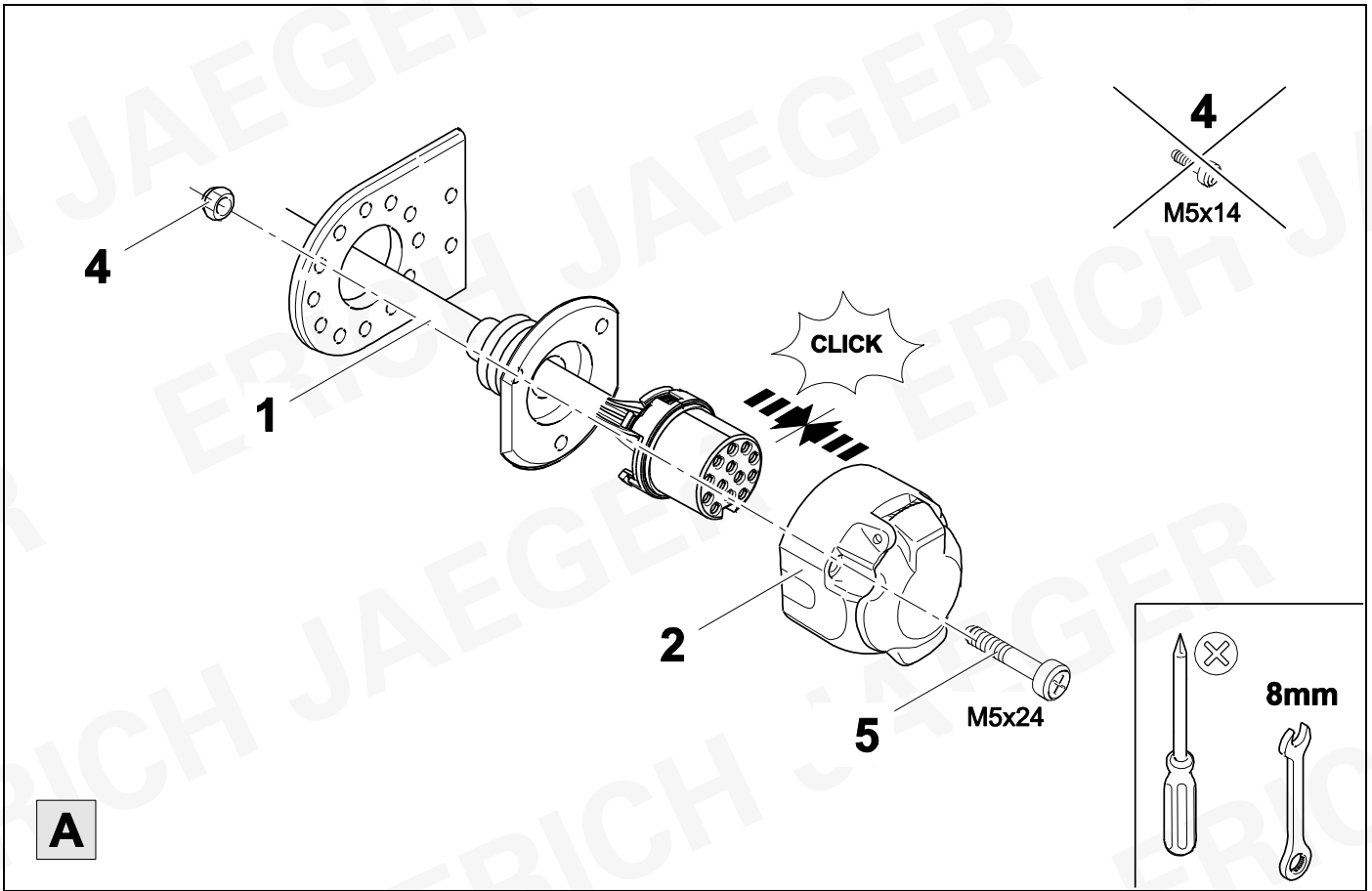

7



8

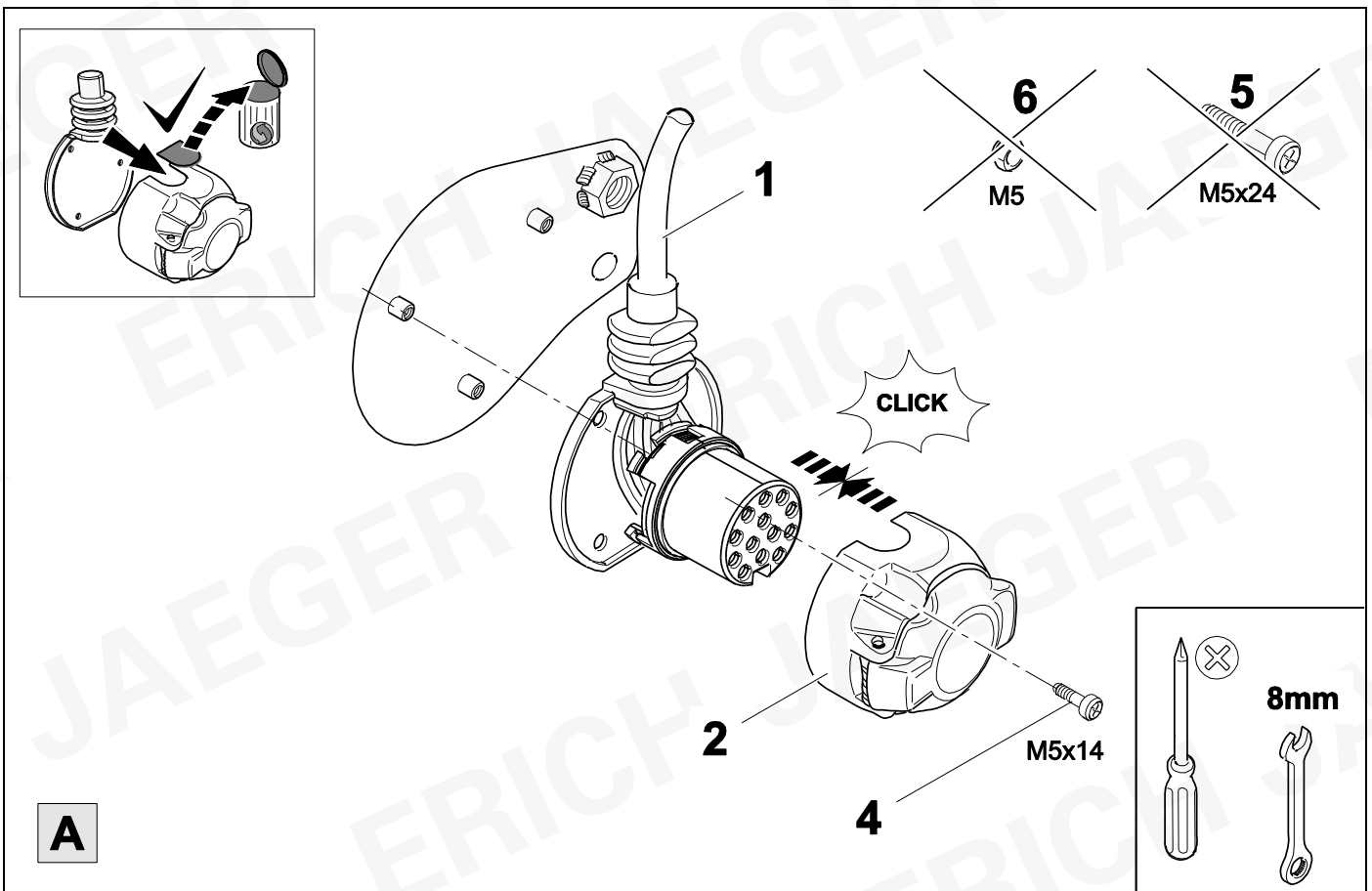

8



9

1	bk/wh		8	bu/rd	
2	gy		9	rd/bu	
3	wh/bn		10	ye	
4	bk/gn		11	bn/gn	
5	gy/rd		12	no	
6	bk/rd		13	bn	
7	gy/bk				

9	bk	wh	gy	gn	rd	bu	ye	bn	pu	or	no
<b>(D)</b>	schwarz	weiß	grau	grün	rot	blau	gelb	braun	violett	orange	nicht belegt
<b>(GB)</b>	black	white	grey	green	red	blue	yellow	brown	purple	orange	not occupied
<b>(F)</b>	noir	blanc	gris	vert	rouge	bleu	jaune	brun	violet	orange	inutilisé
<b>(NL)</b>	zwart	wit	grijs	groen	rood	blauw	geel	bruin	violet	oranje	niet aangesloten
<b>(DK)</b>	sort	hvid	grå	grøn	rød	blå	gul	brun	violet	orange	ikke anvendt
<b>(N)</b>	svart	hvit	grå	grønn	rød	blå	gul	brun	fiolett	oransje	ikke i bruk
<b>(S)</b>	svart	vit	grå	grön	röd	blå	gul	brun	violett	orange	ej använd
<b>(FIN)</b>	musta	valkoinen	harmaa	vihreä	punainen	sininen	keltainen	ruskea	violetti	oranssi	ei varattu
<b>(I)</b>	nero	bianco	grigio	verde	rosso	blu	giallo	marrone	viola	arancione	libero
<b>(E)</b>	negro	blanco	gris	verde	rojo	azul	amarillo	marrón	violeta	anaranja-do	no ocupado
<b>(P)</b>	preto	branco	cinzento	verde	vermelho	azul	amarelo	castanho	violeta	laranja	não ocupado
<b>(GR)</b>	μαύρος	λευκός	Γκρι	πράσινος	κόκκινος	μπλε	κίτρινος	καφέ	Μωβ	πορτοκαλί	δεν είναι κατ'επιτημένος
<b>(PL)</b>	czarny	biały	szary	zielony	czerwony	niebiesko	żółty	brazowy	fioletowy	pomarańczowy	wolny
<b>(CZ)</b>	černý	bílý	šedý	zelený	červený	modrý	žlutý	hnědý	fialový	oranžový	neobsazen
<b>(TR)</b>	siyah	beyaz	gri	yeşil	kırmızı	mavi	sarı	kahverengi	mor	portakal rengi	boş
<b>(H)</b>	fekete	fehér	szürke	zöld	piros	kék	sárga	barna	ibolyakék	narancssárga	nem foglalt
<b>(HR)</b>	crno	bijelo	sivo	zeleno	crveno	plavo	zuto	smeđe	ljubičasto	narandžasto	nije zauzeto
<b>(BUL)</b>	черен	бял	сив	зелен	червен	син	жълт	кафяв	виолетов	оранжев	свободно
<b>(RO)</b>	negru	alb	gri	verde	roșu	albastru	galben	maro	violet	portocaliu	liber
<b>(RU)</b>	черный	белый	серый	зеленый	красный	голубой	жёлтый	коричневый	пурпурный	оранжевый	свободно
<b>(LT)</b>	juoda	balta	pilka	žalia	raudona	mėlyna	geltona	ruda	purpurinė	oranžinė	laisva
<b>(LV)</b>	melna	balta	pelēka	zaļa	sarkana	zila	dzeltena	brūna	purpur-sarkana	oranža	brīvs
<b>(EST)</b>	must	valge	hall	roheline	punane	sinine	kollane	pruun	purpur-punane	oraanž	vaba
<b>(SLO)</b>	črna	bela	siva	zelena	rdeča	modra	rumena	smeđ	vijoličast	oranžen	ni zasedeno
<b>(SK)</b>	čierny	biely	šedý	zelený	červený	modrý	žltý	hnědý	fialový	pomaraňový	neobsadený



10

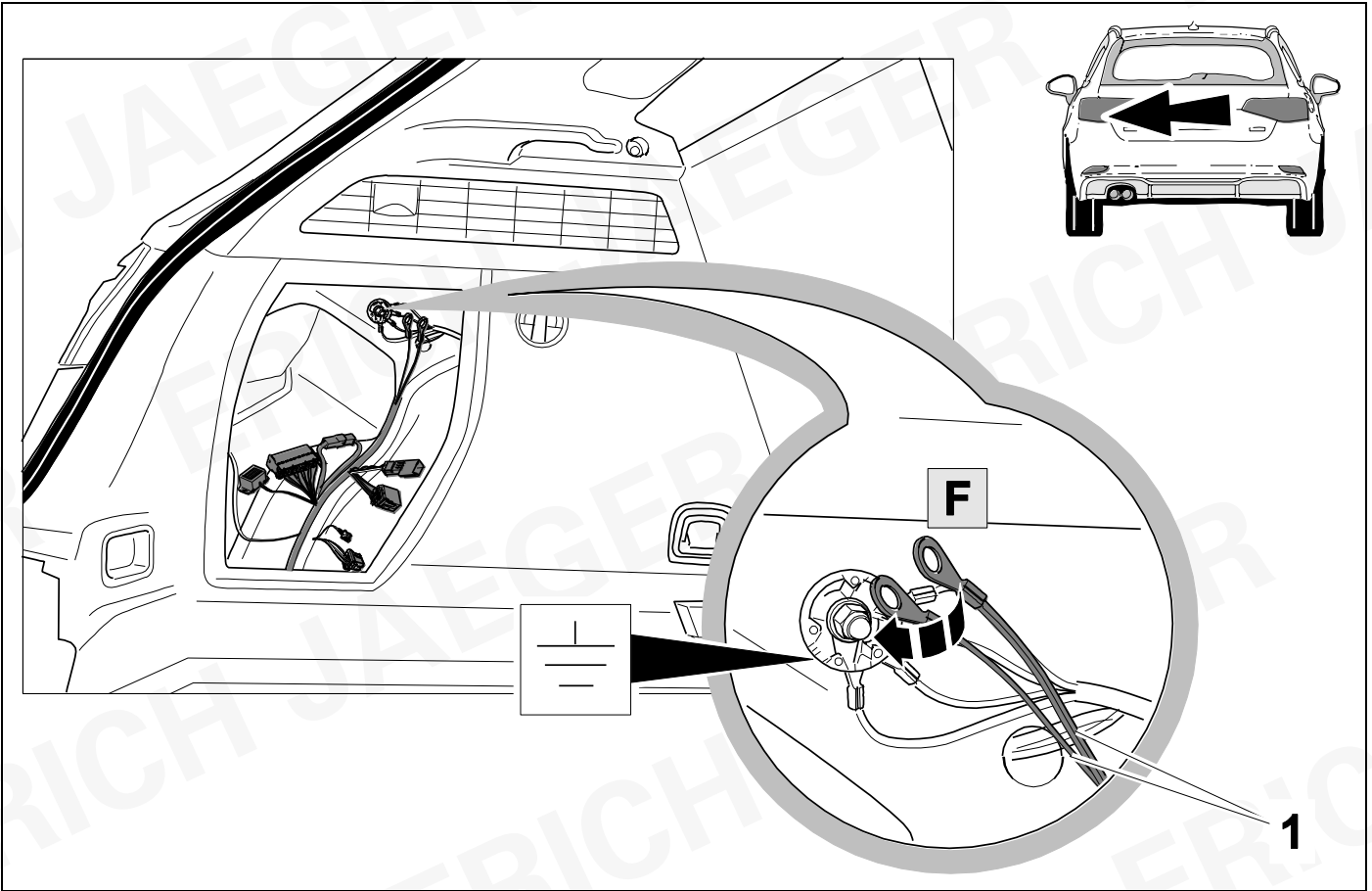

11



**Fahrzeuge mit Anhängervorbereitung**  
**Vehicles with trailer preparation**

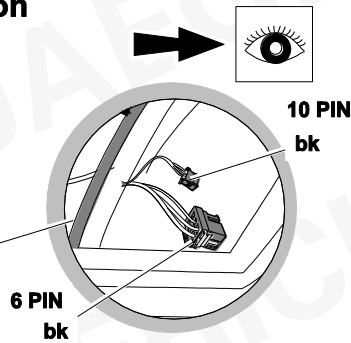
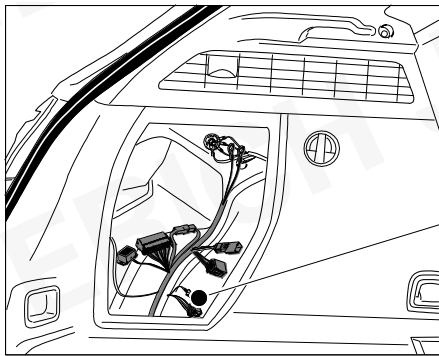

**OPTION 1**

12 ⇒ 17

35 ⇒ 47

**Fahrzeuge ohne Anhängervorbereitung**  
**Vehicles without trailer preparation**

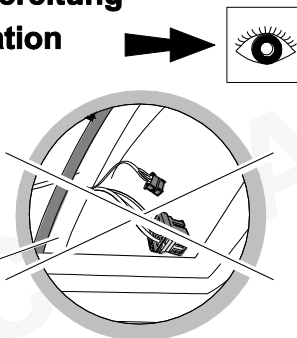
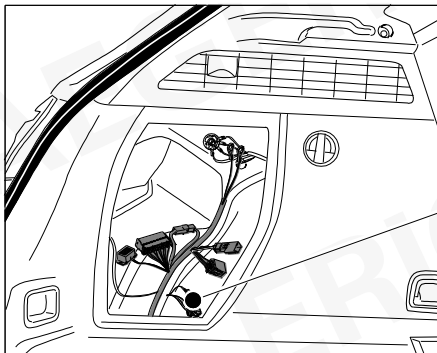

**OPTION 2**

18 ⇒ 47

12

OPTION 1

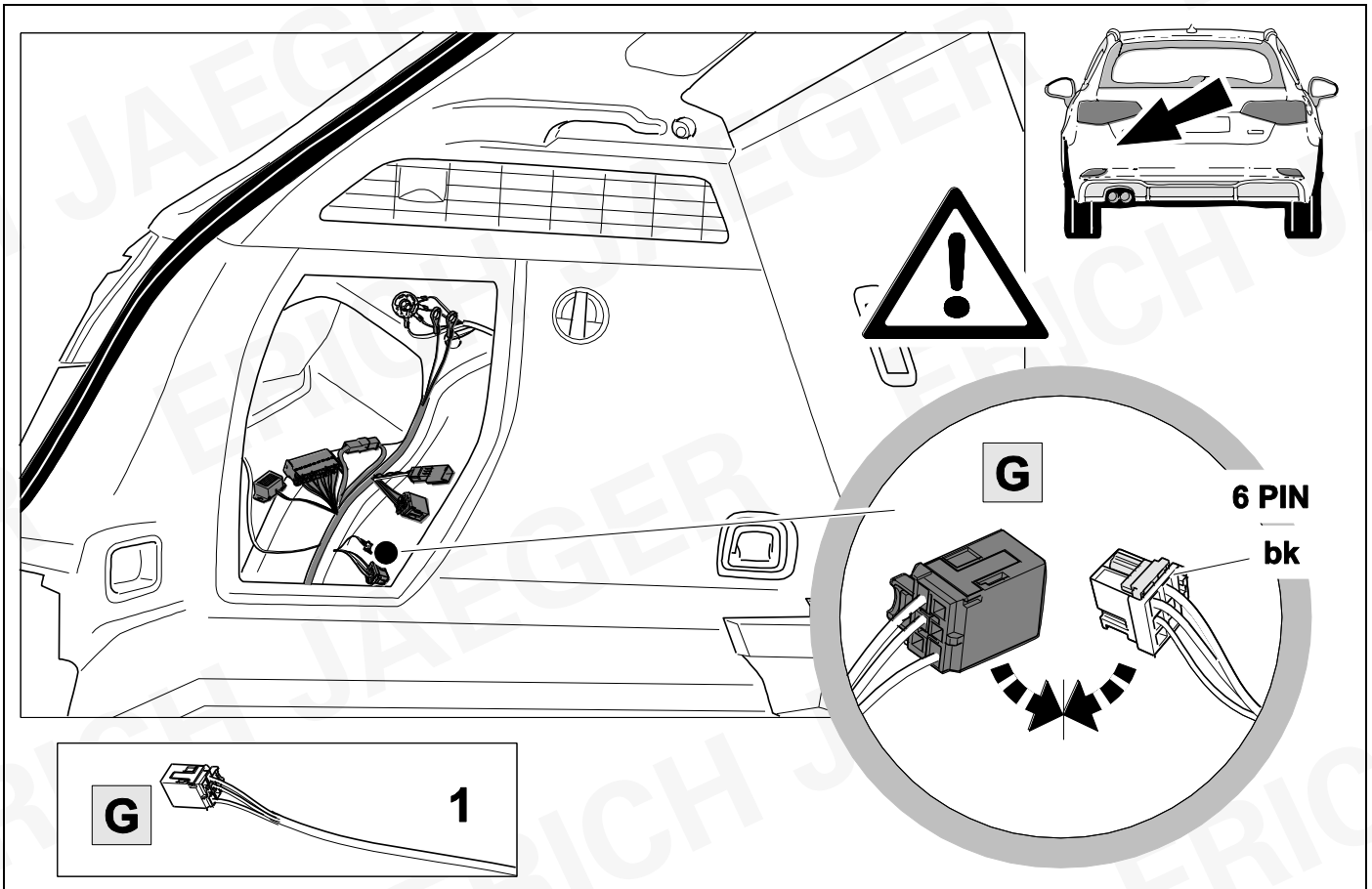

13

OPTION 1

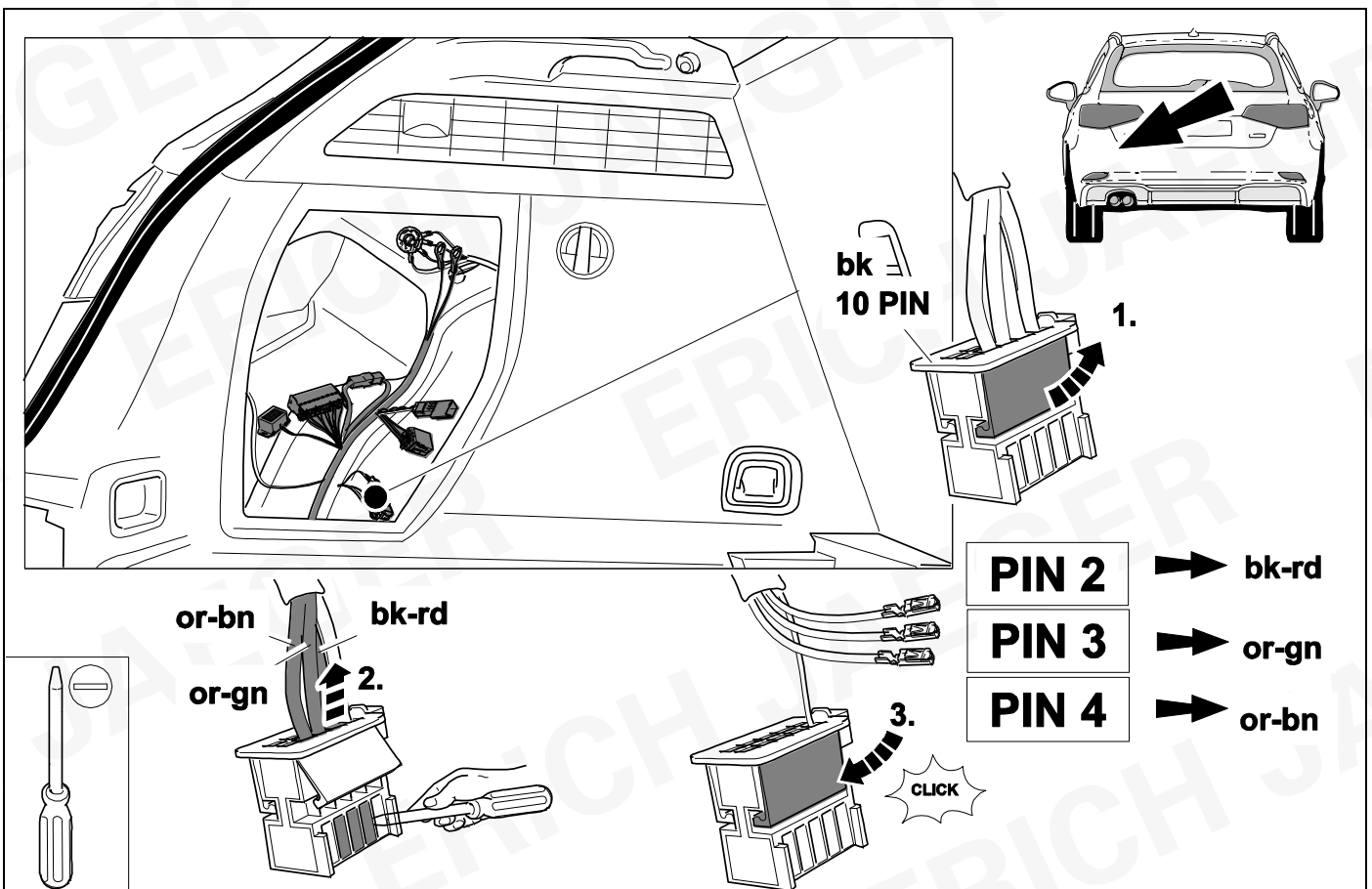

14



9

OPTION 1

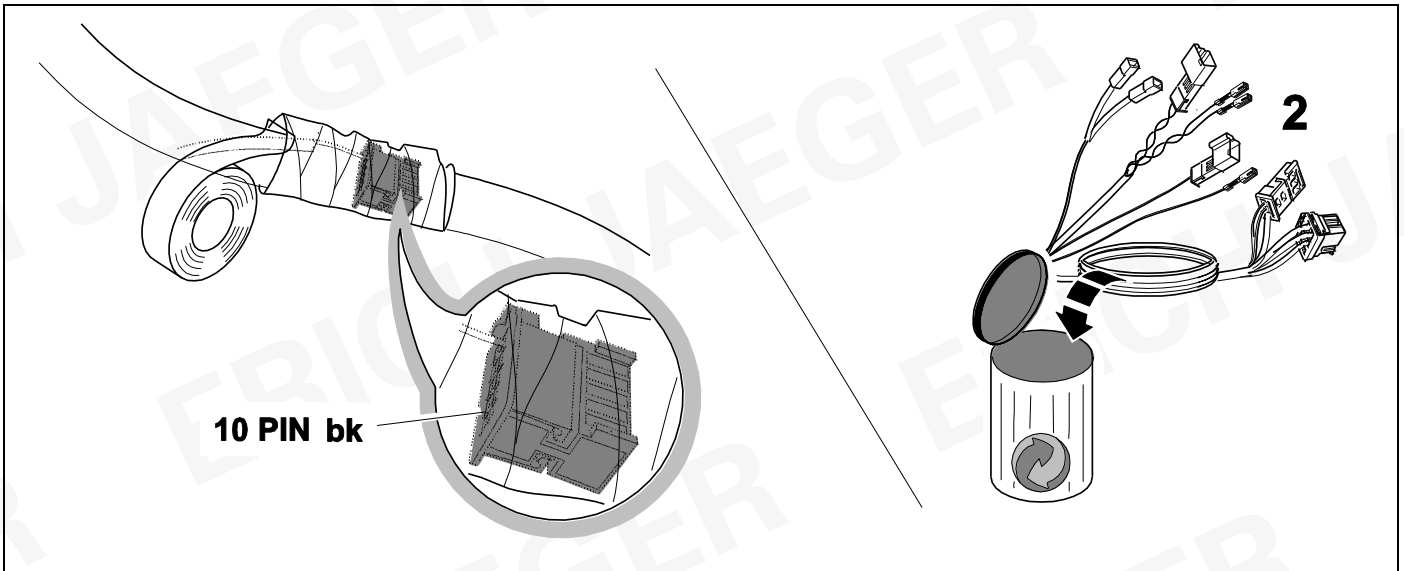

15



9

OPTION 1

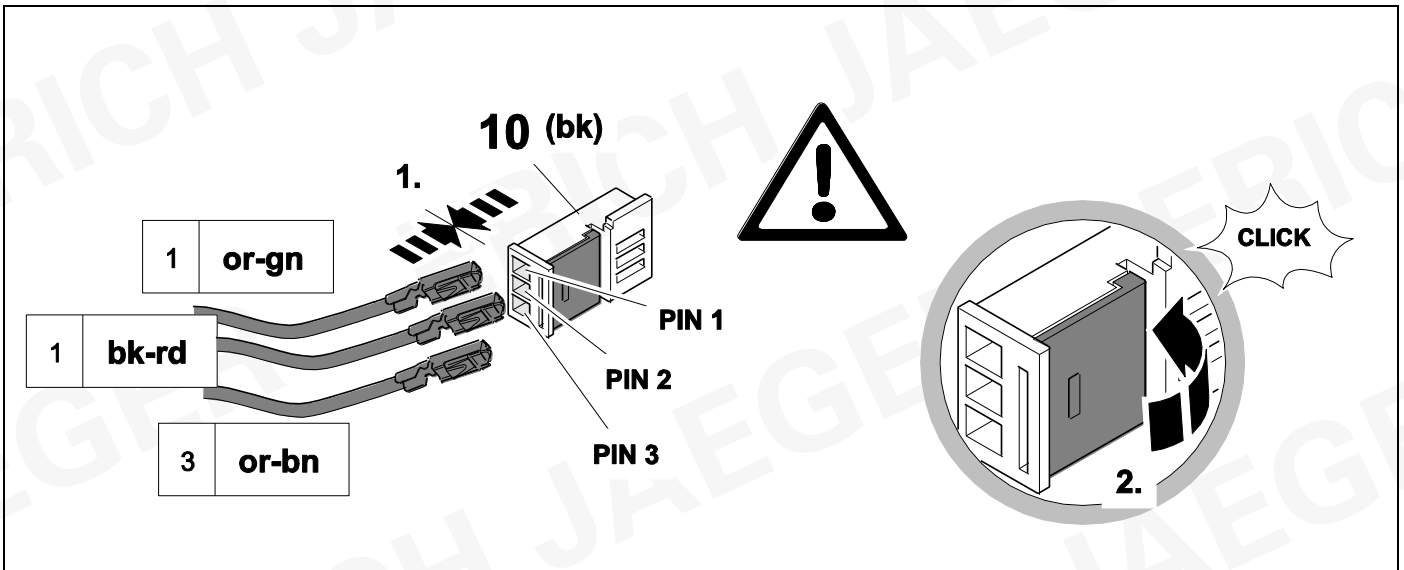

16



9

OPTION 1

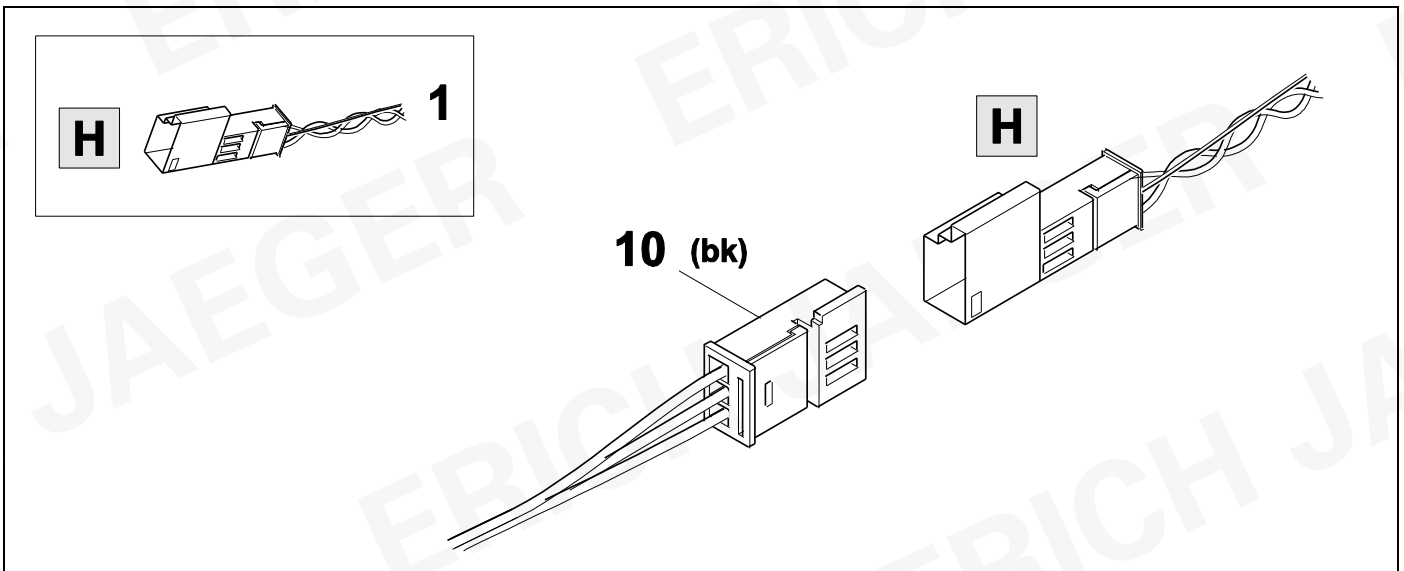

17

OPTION 1

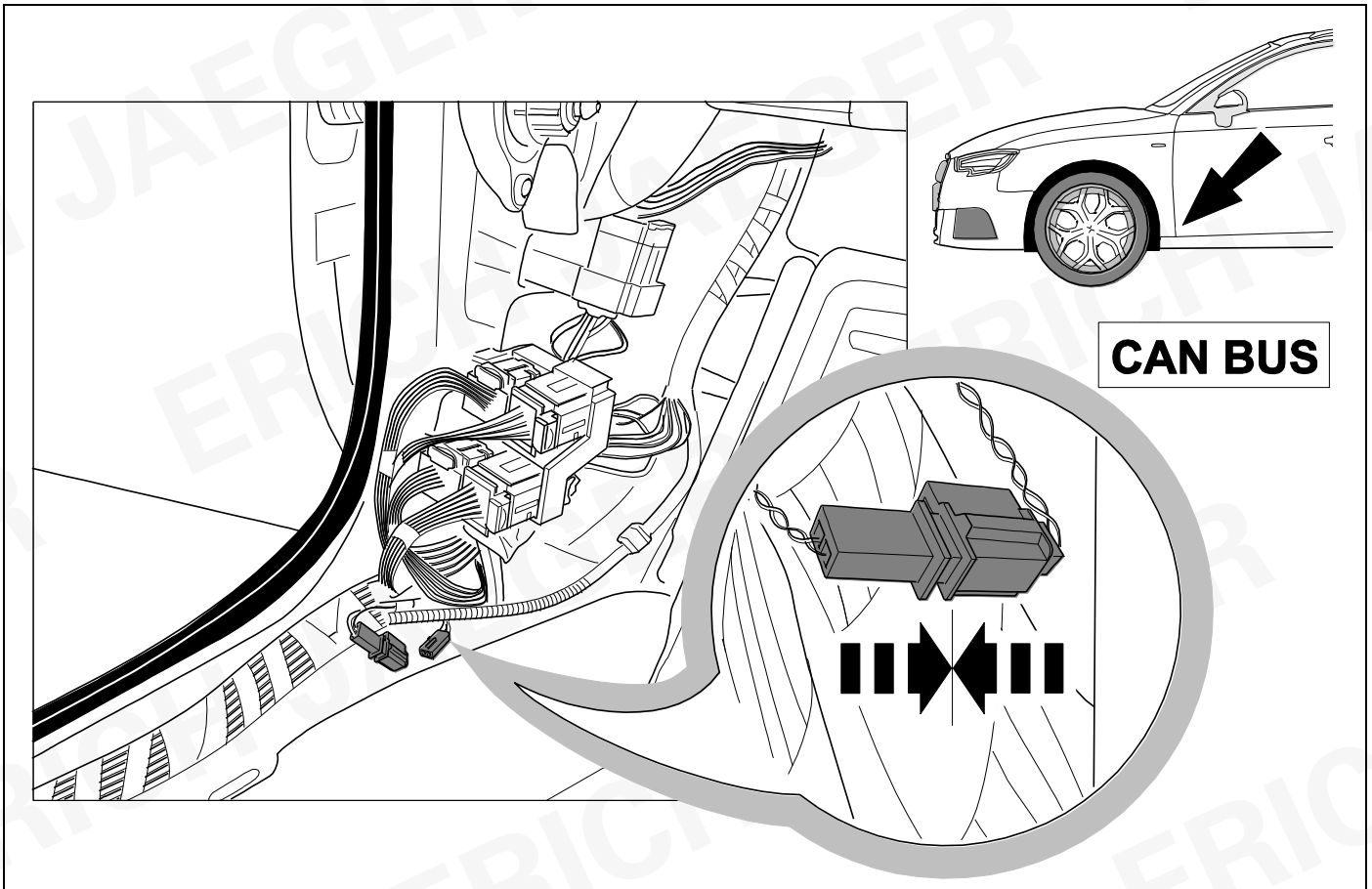

18



42

OPTION 1

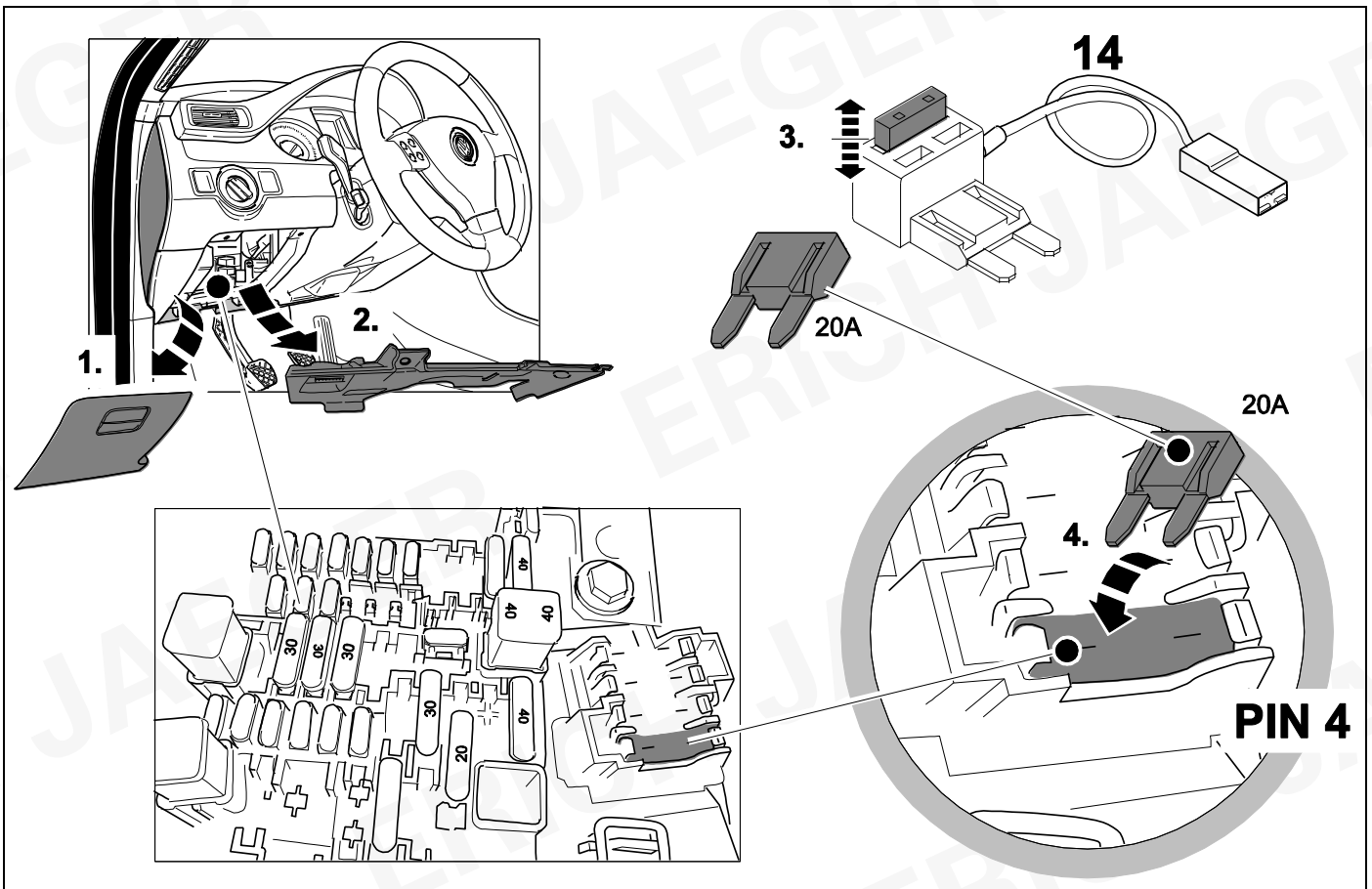

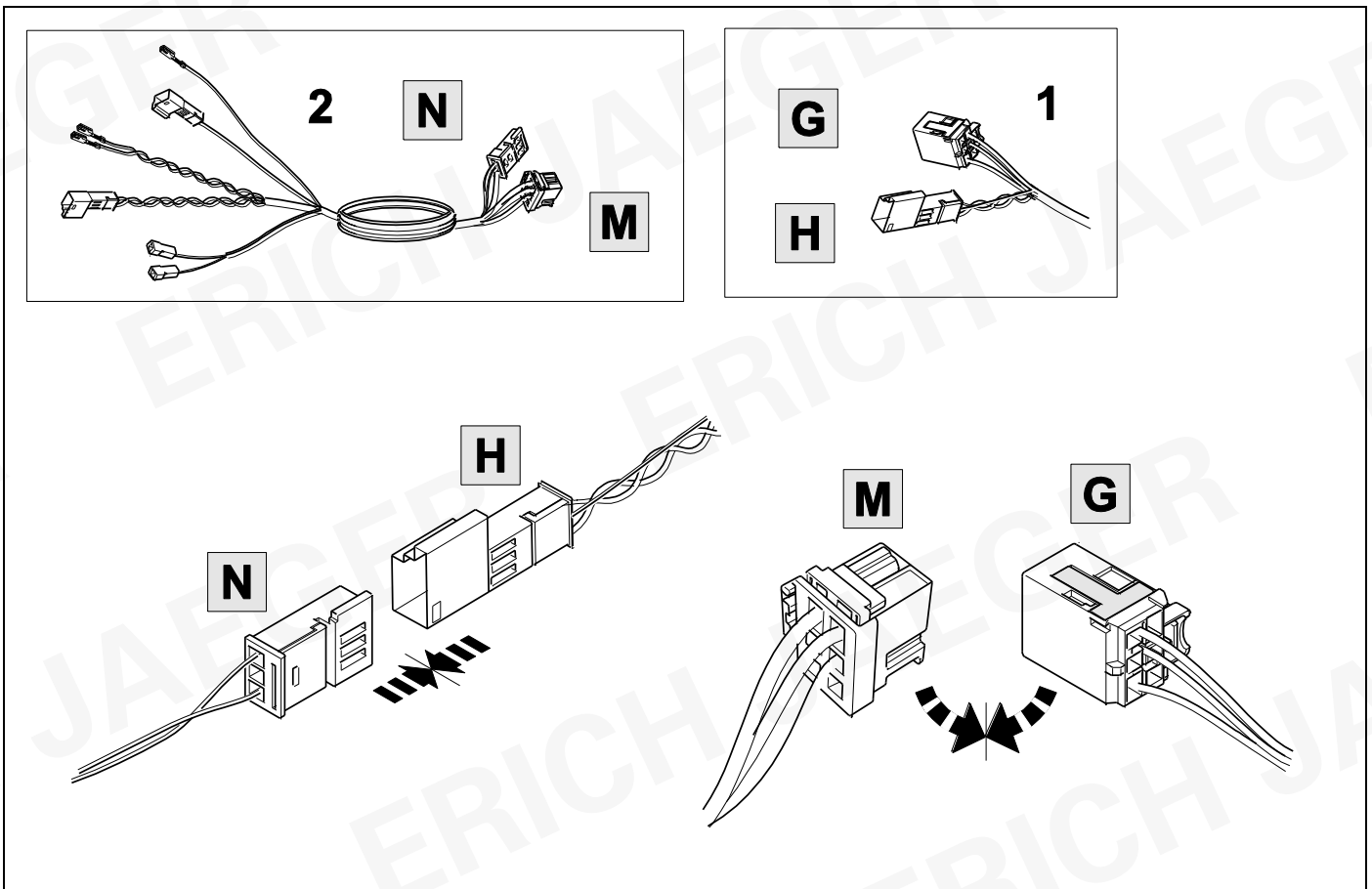
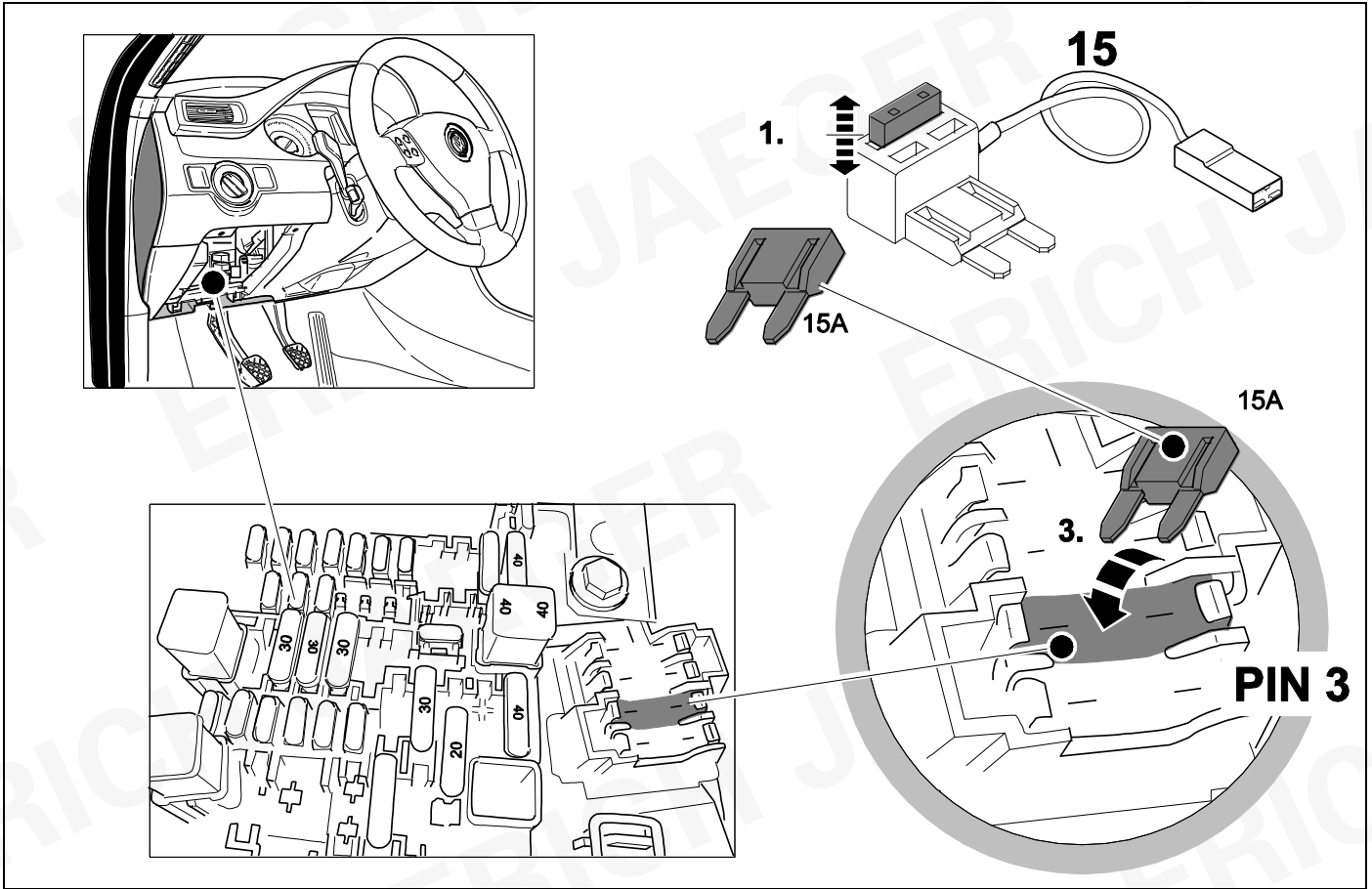

21

OPTION 2

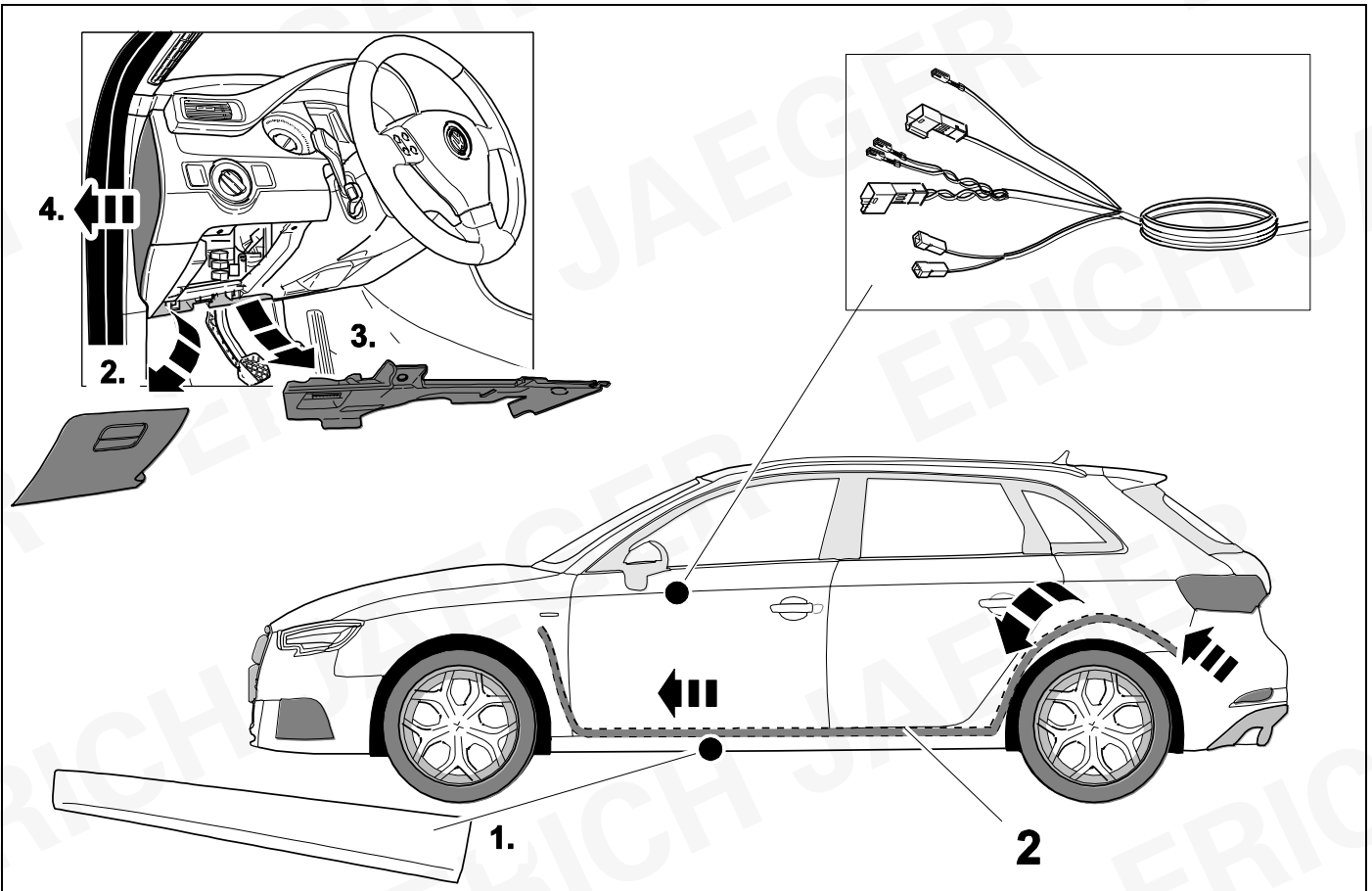

22



9

OPTION 2

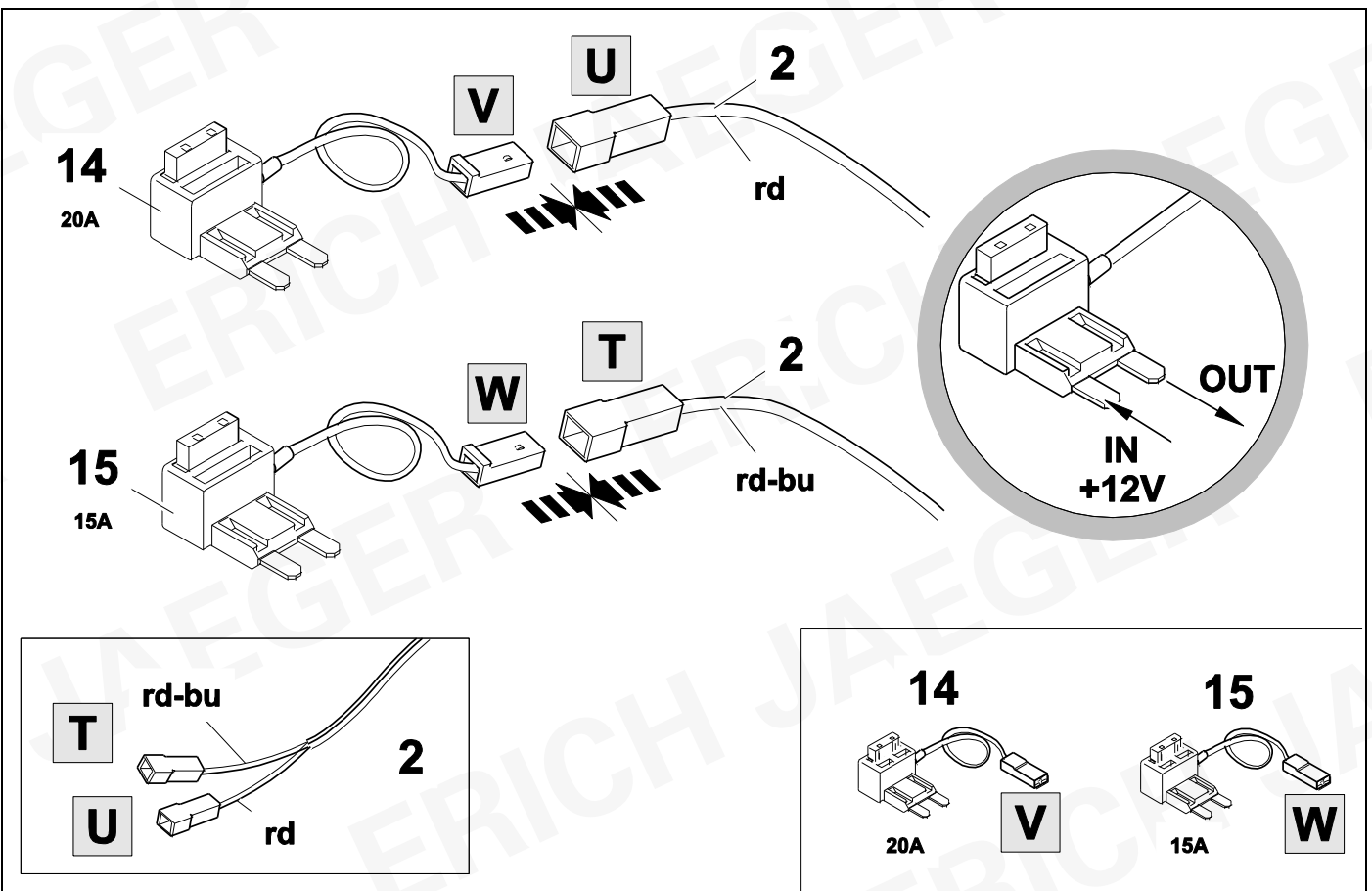

23



42

OPTION 2

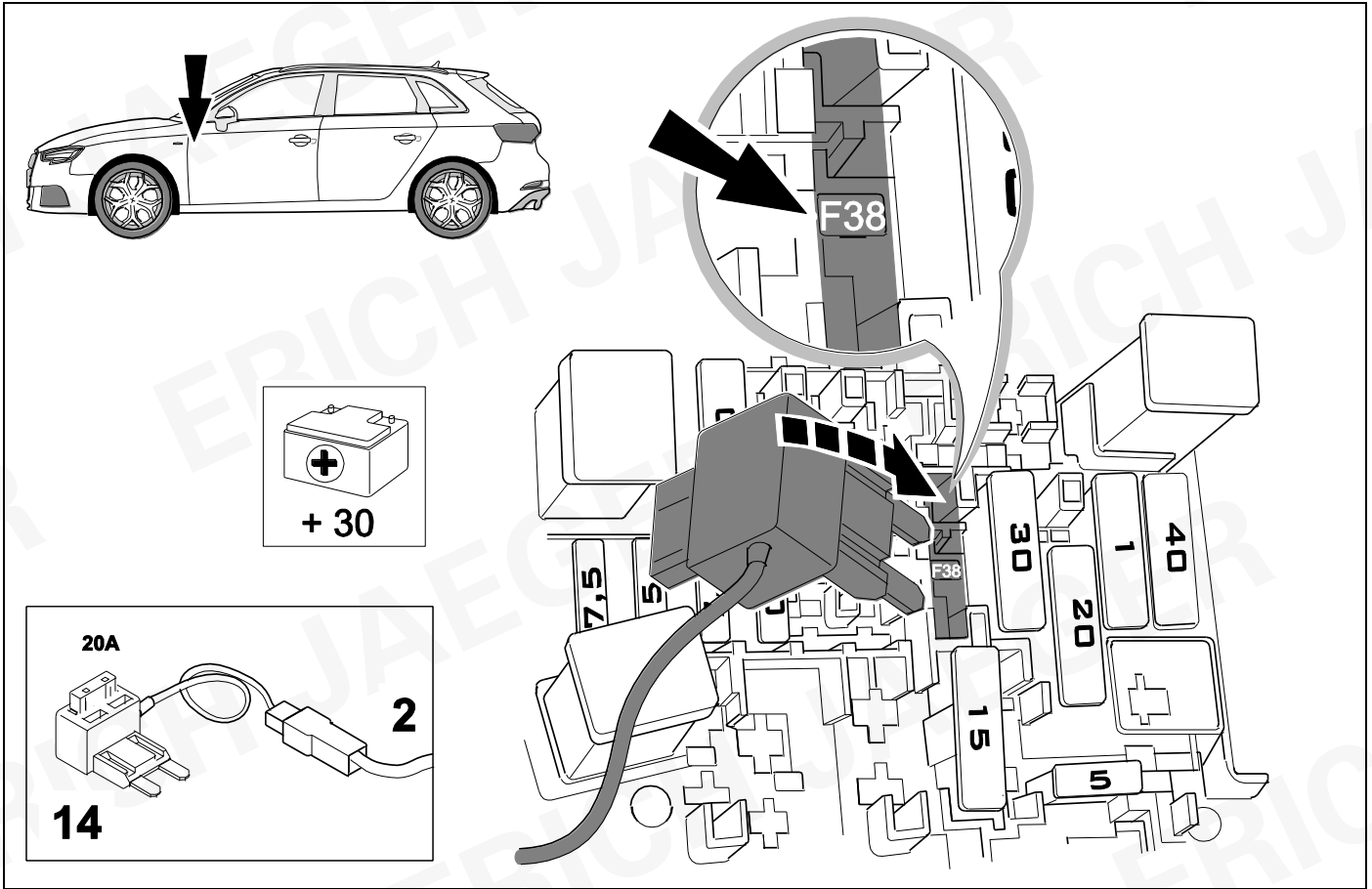

24



42

OPTION 2

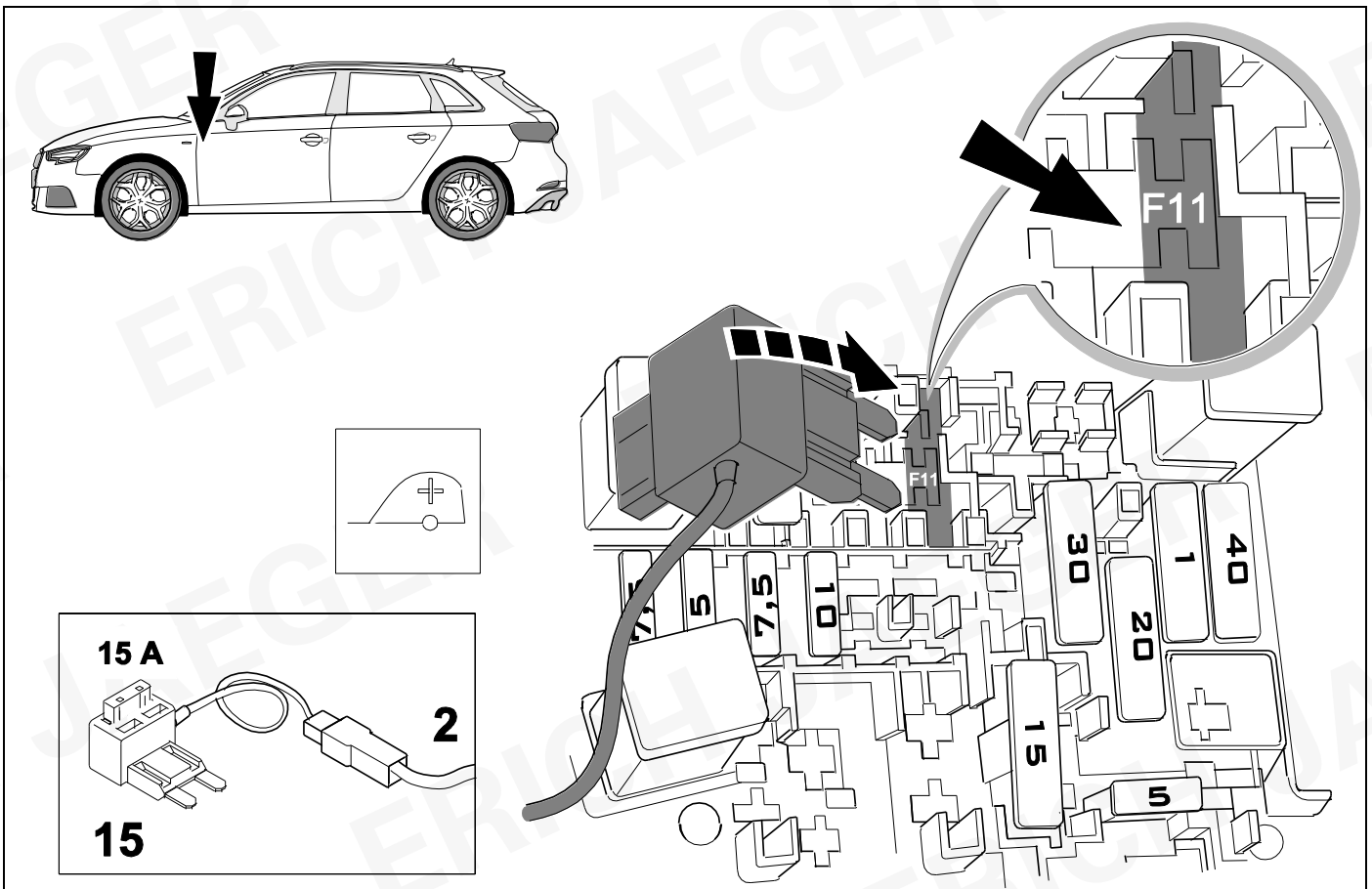

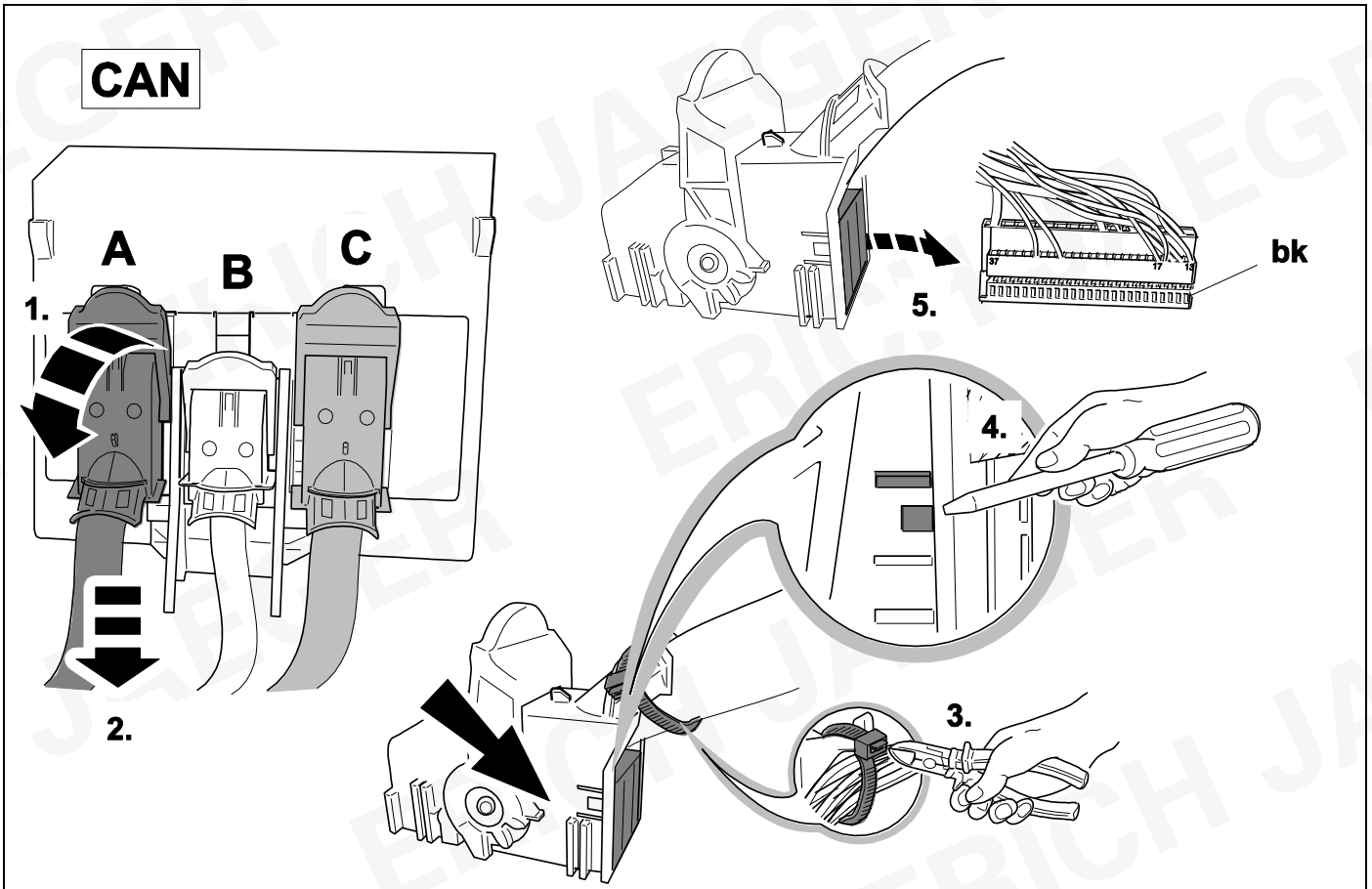
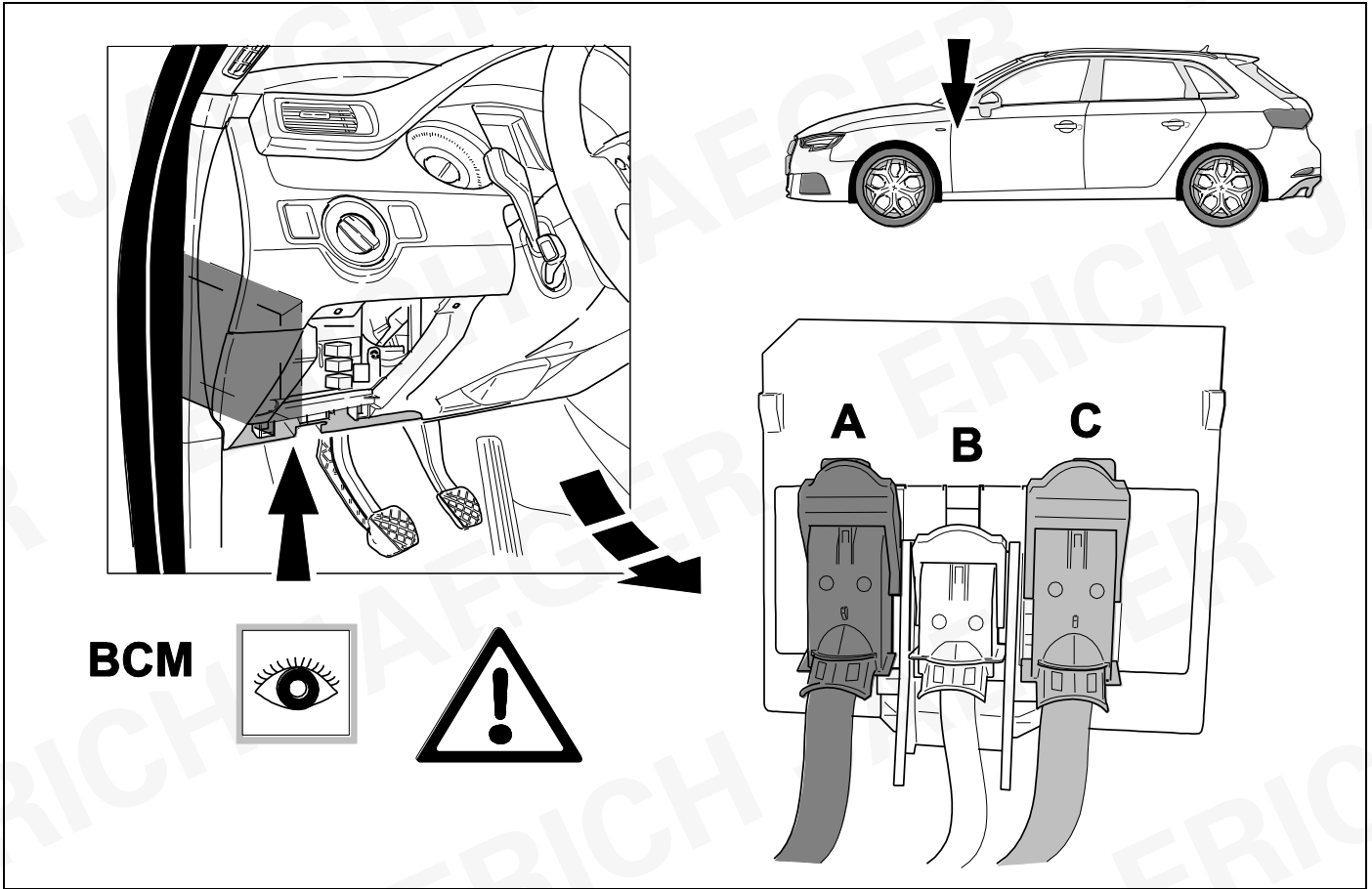



27



9

OPTION 2

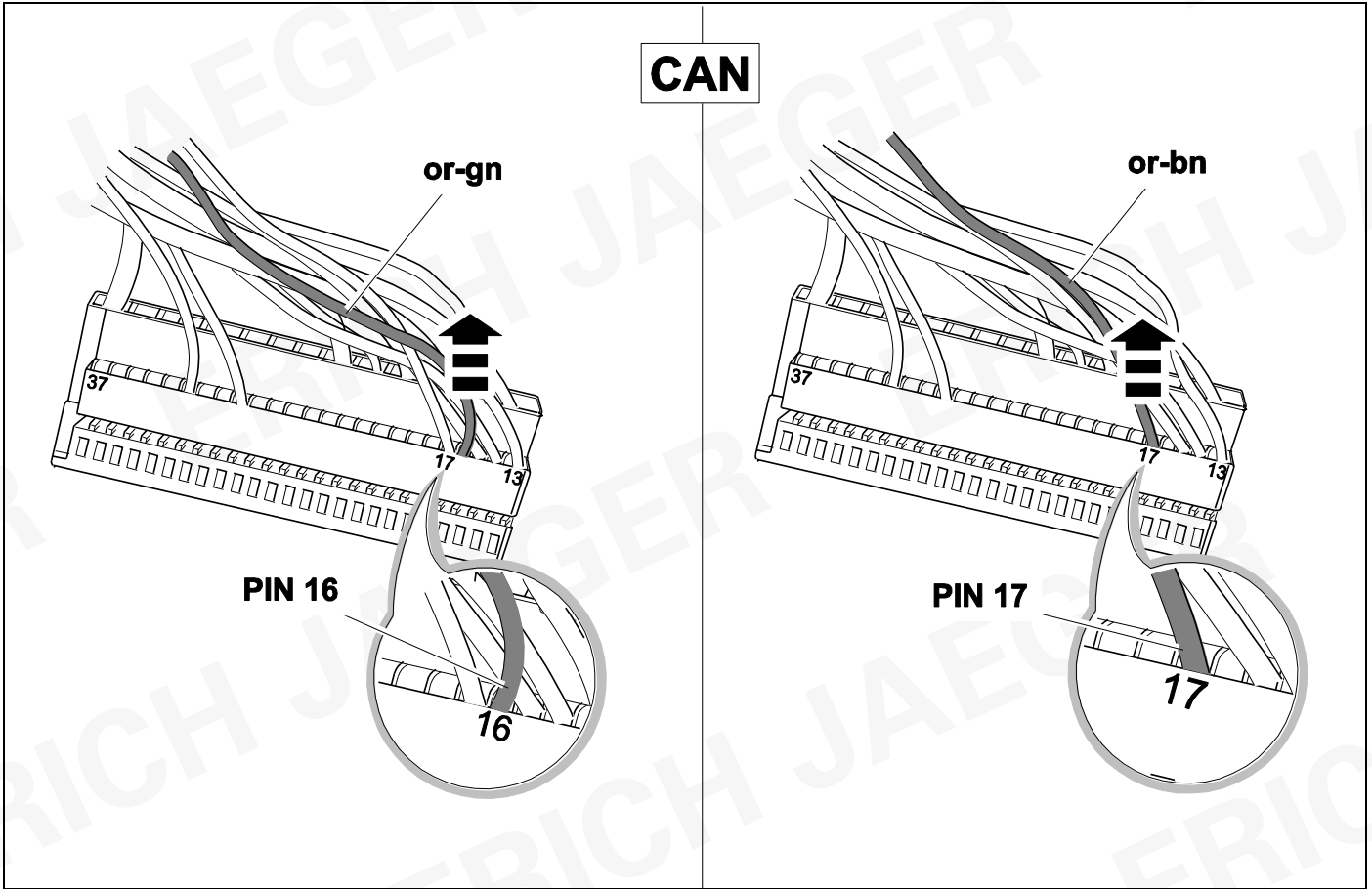

28



9

OPTION 2

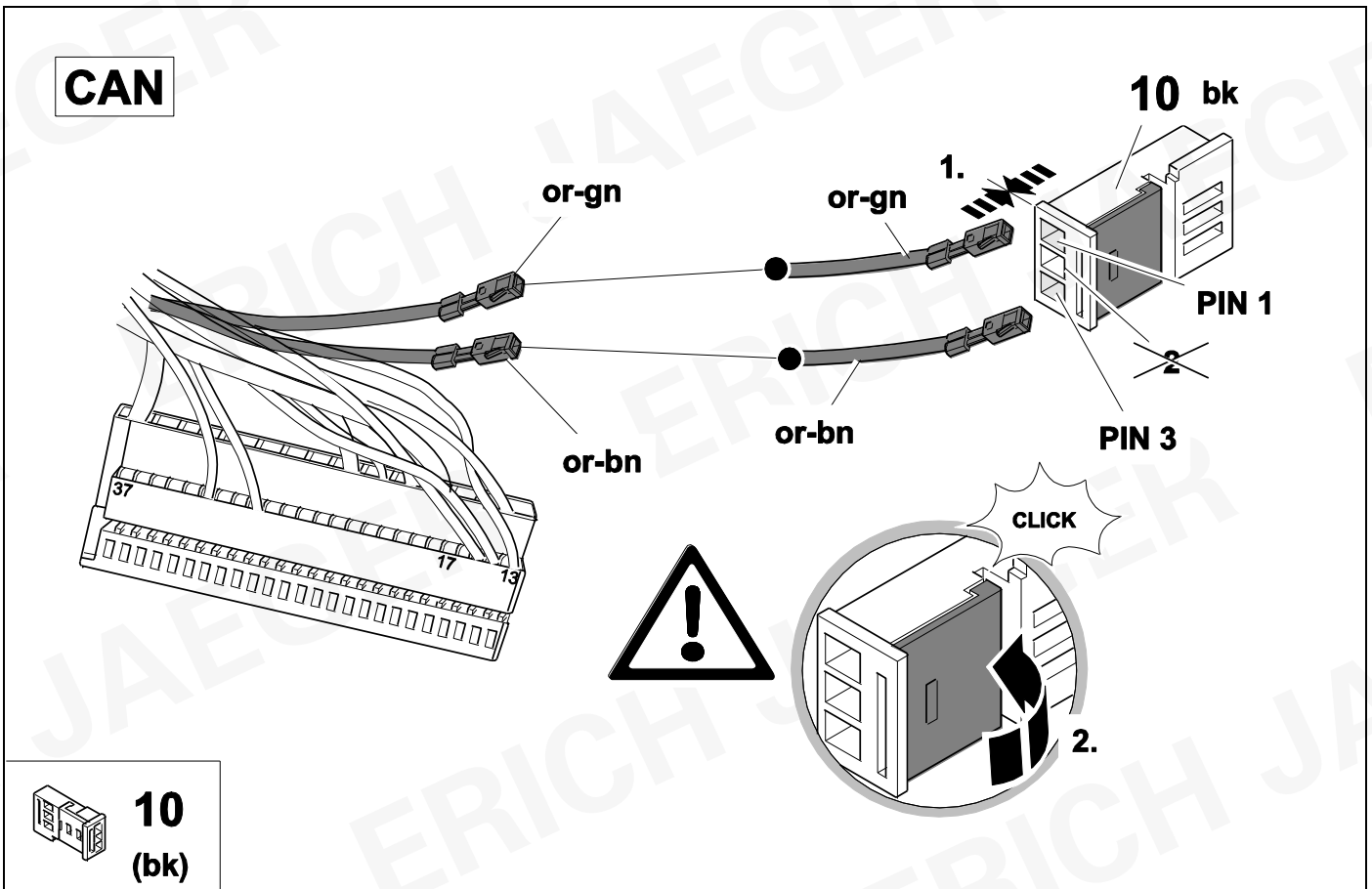

**10**  
**(bk)**

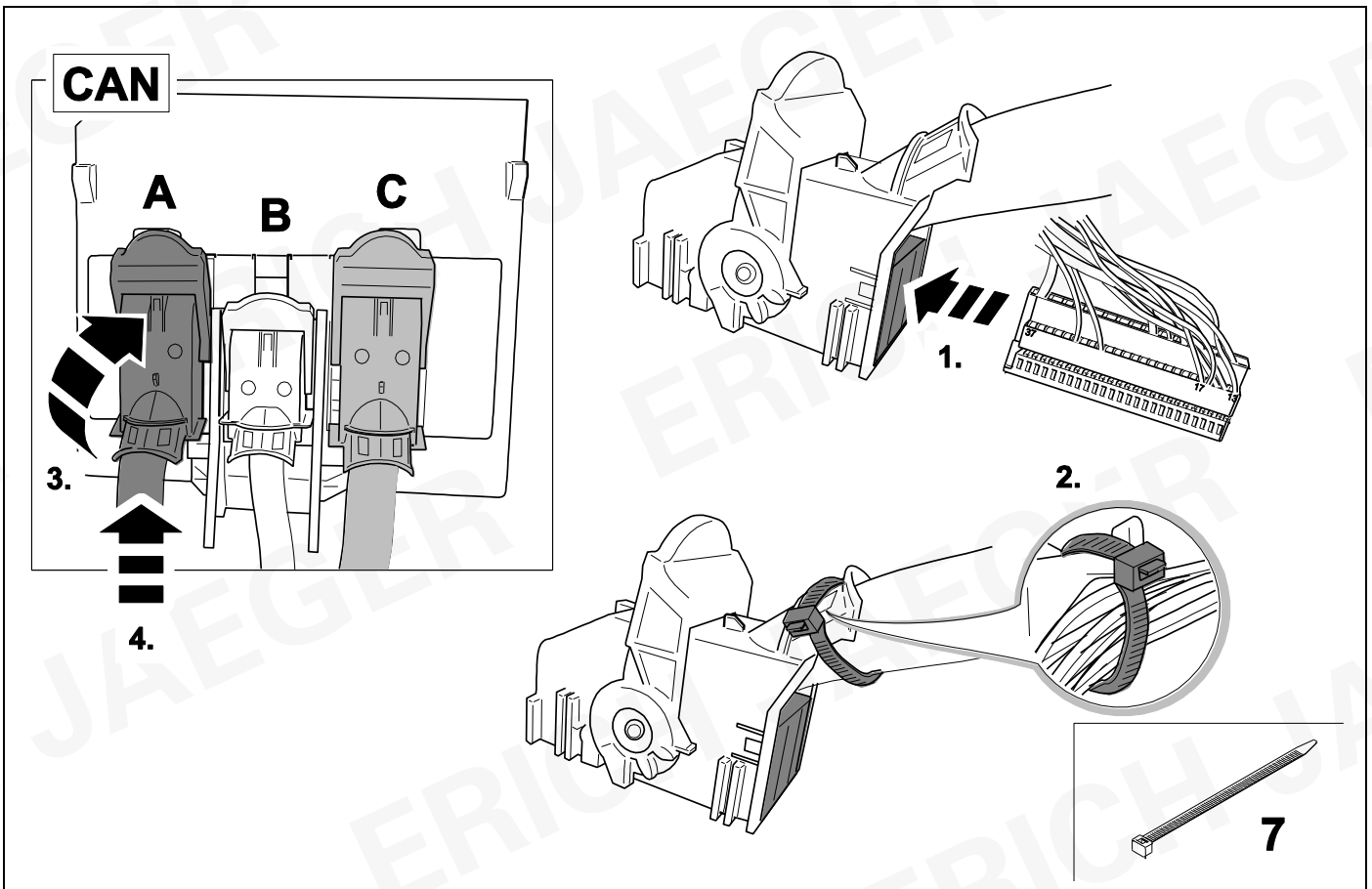
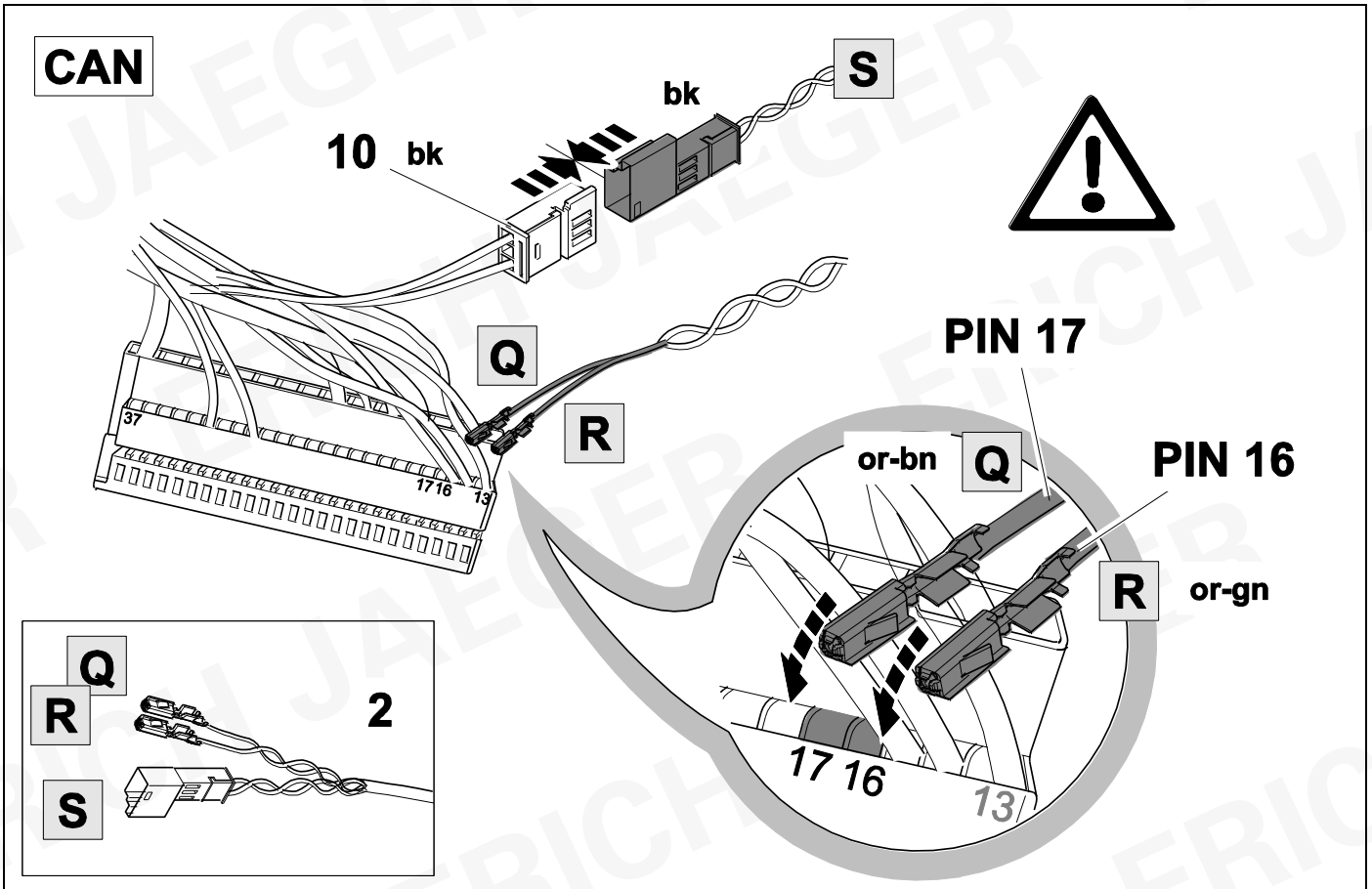

31



9

OPTION 2

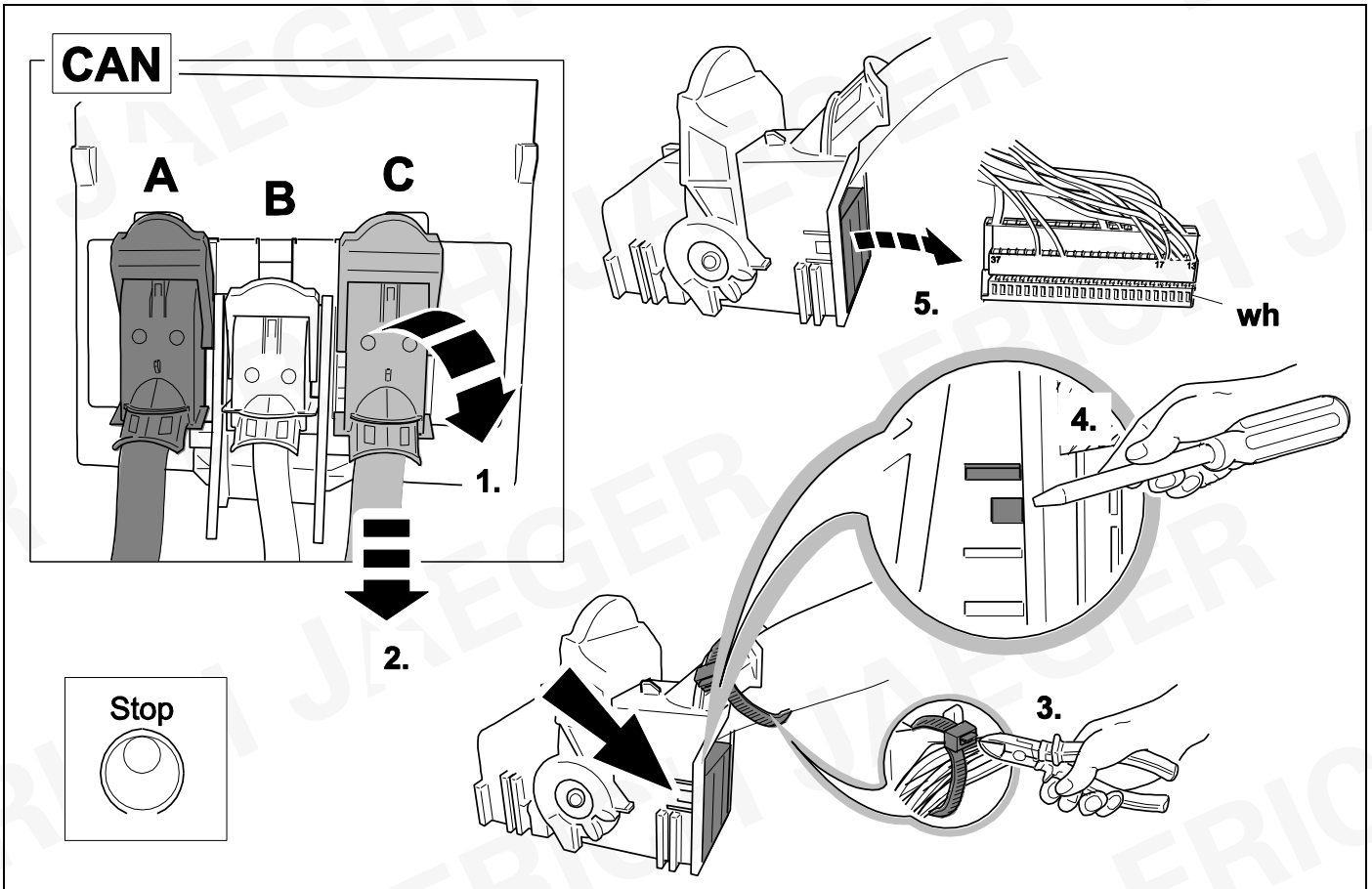

32



9

OPTION 2

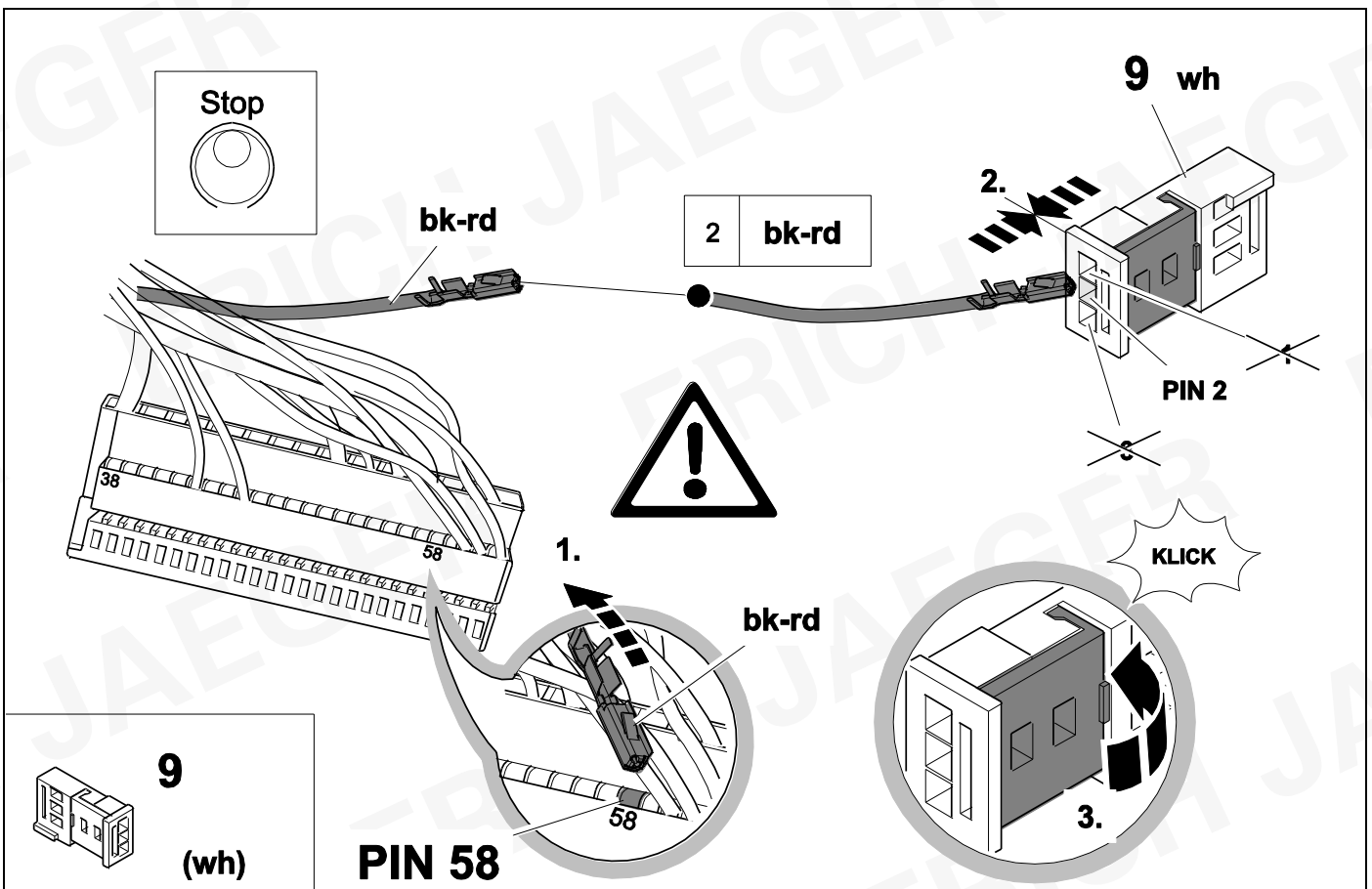

33



9

OPTION 2

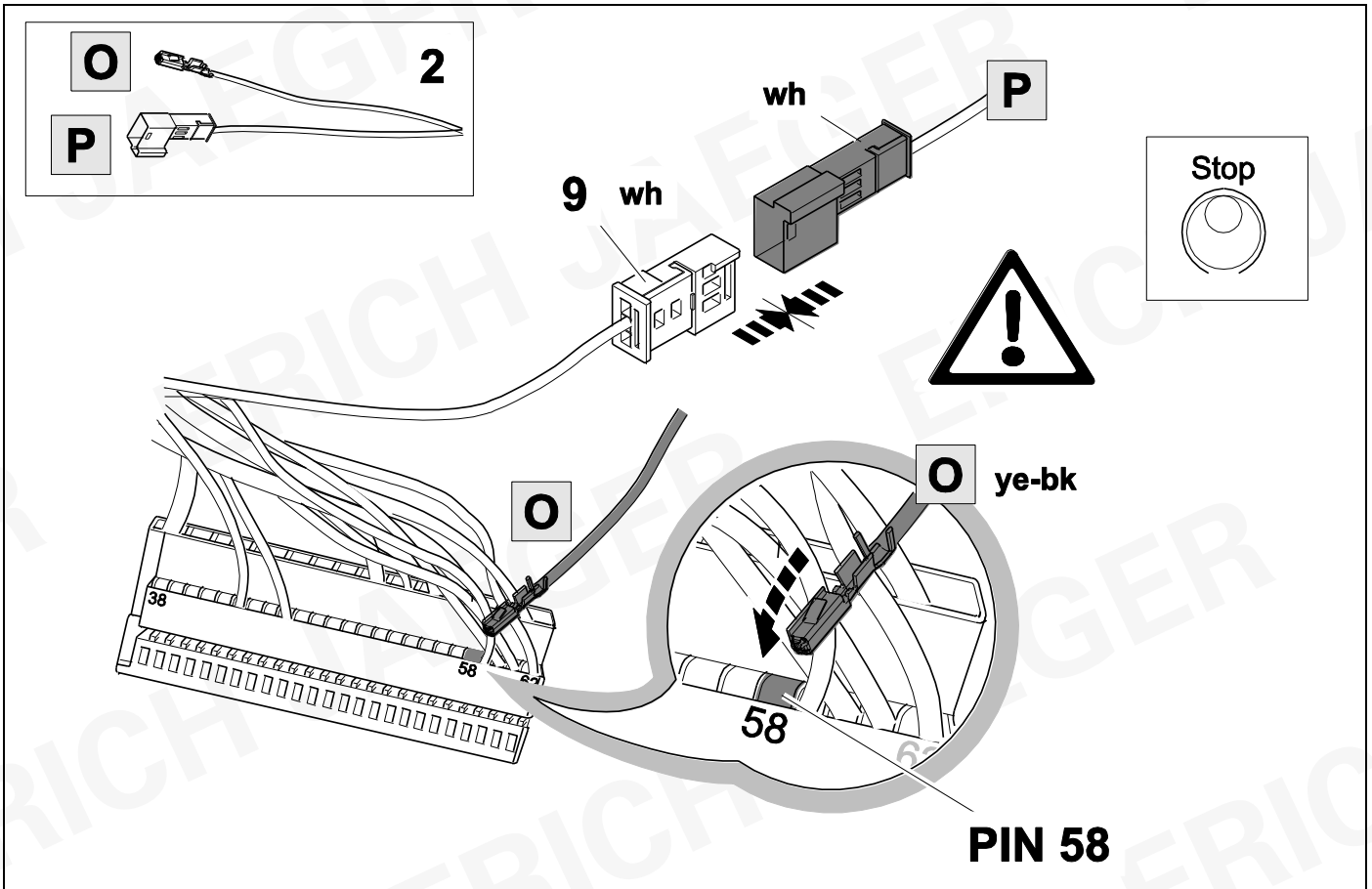

34

OPTION 2

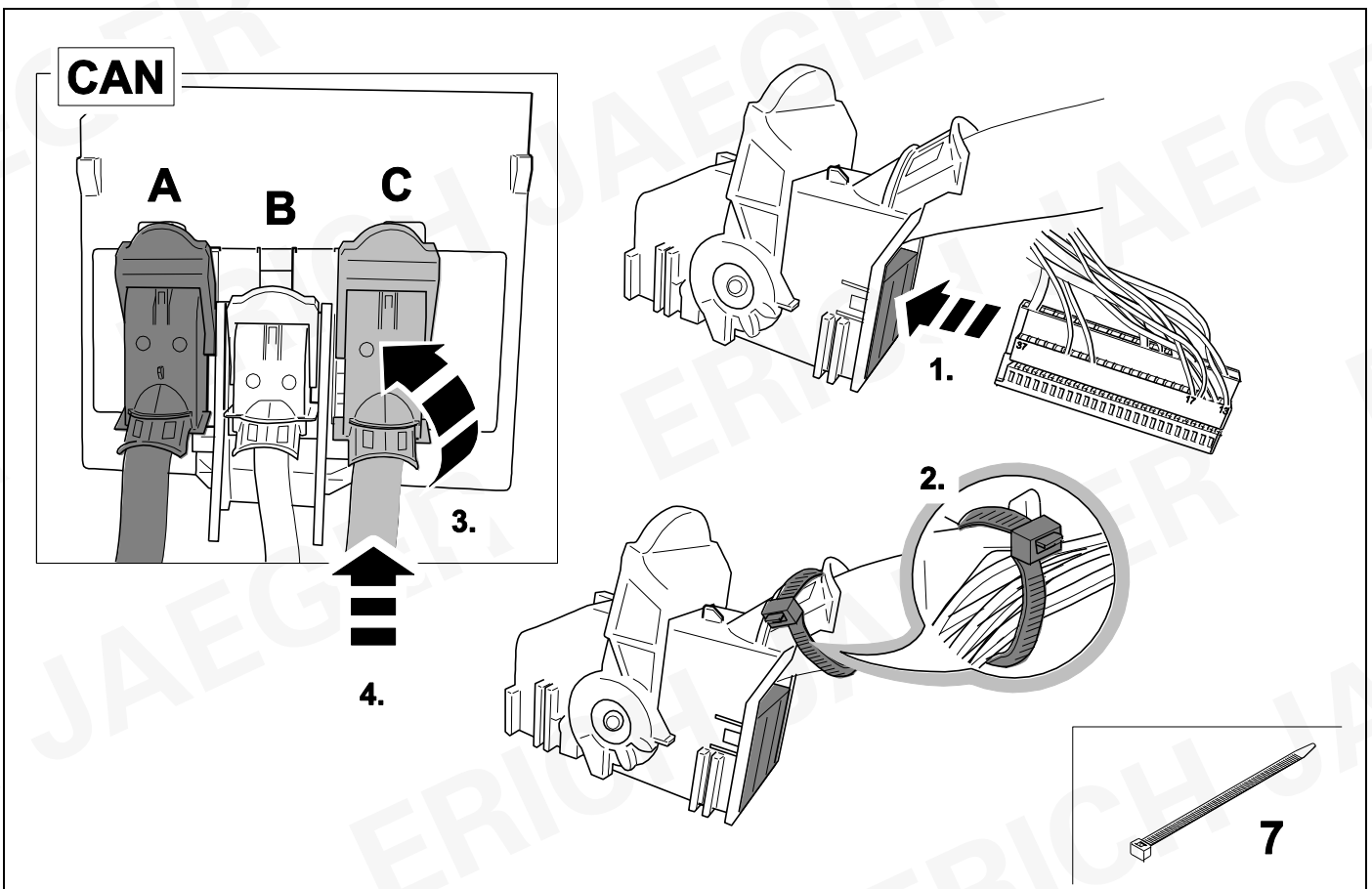

35

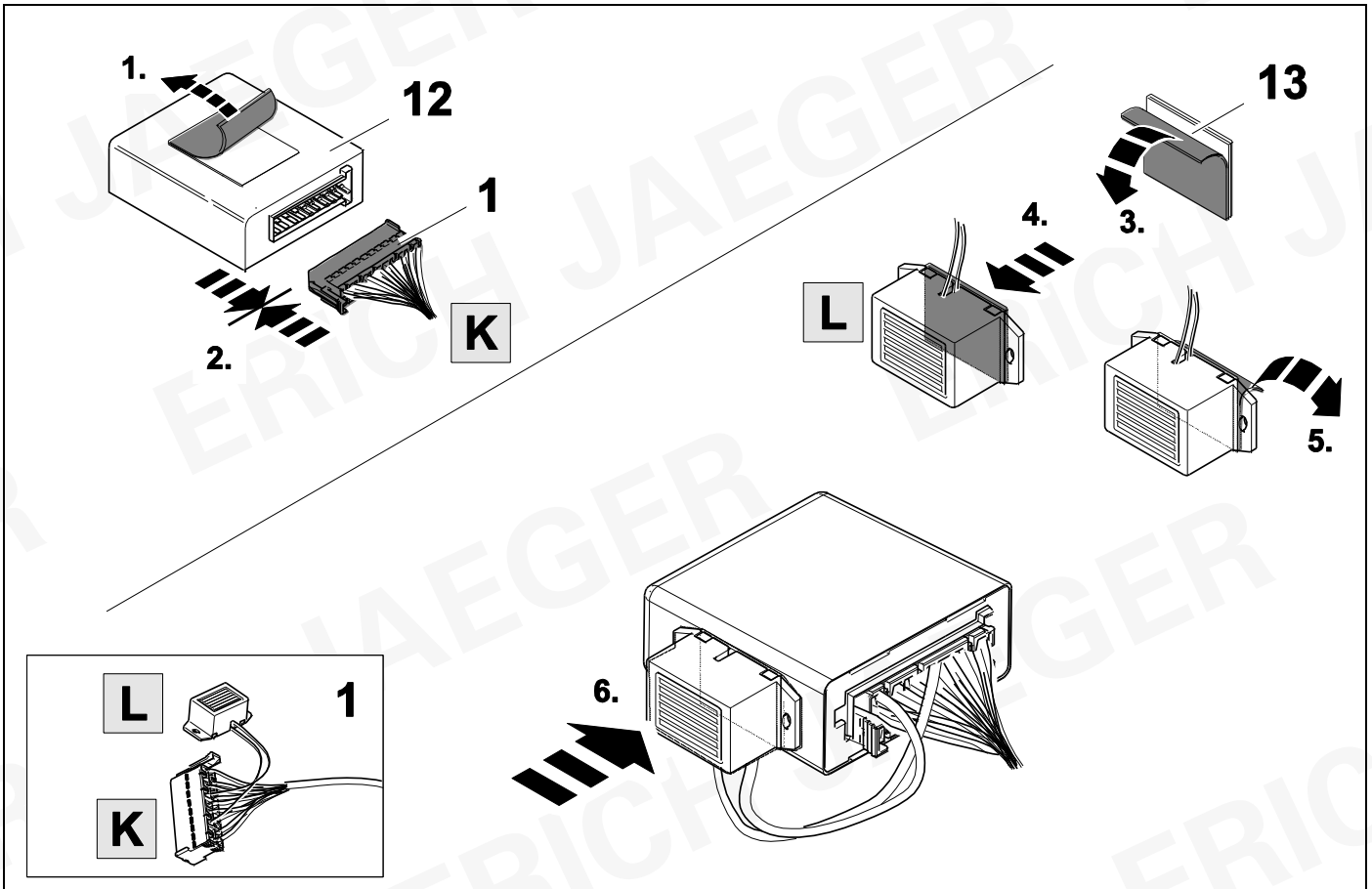

36

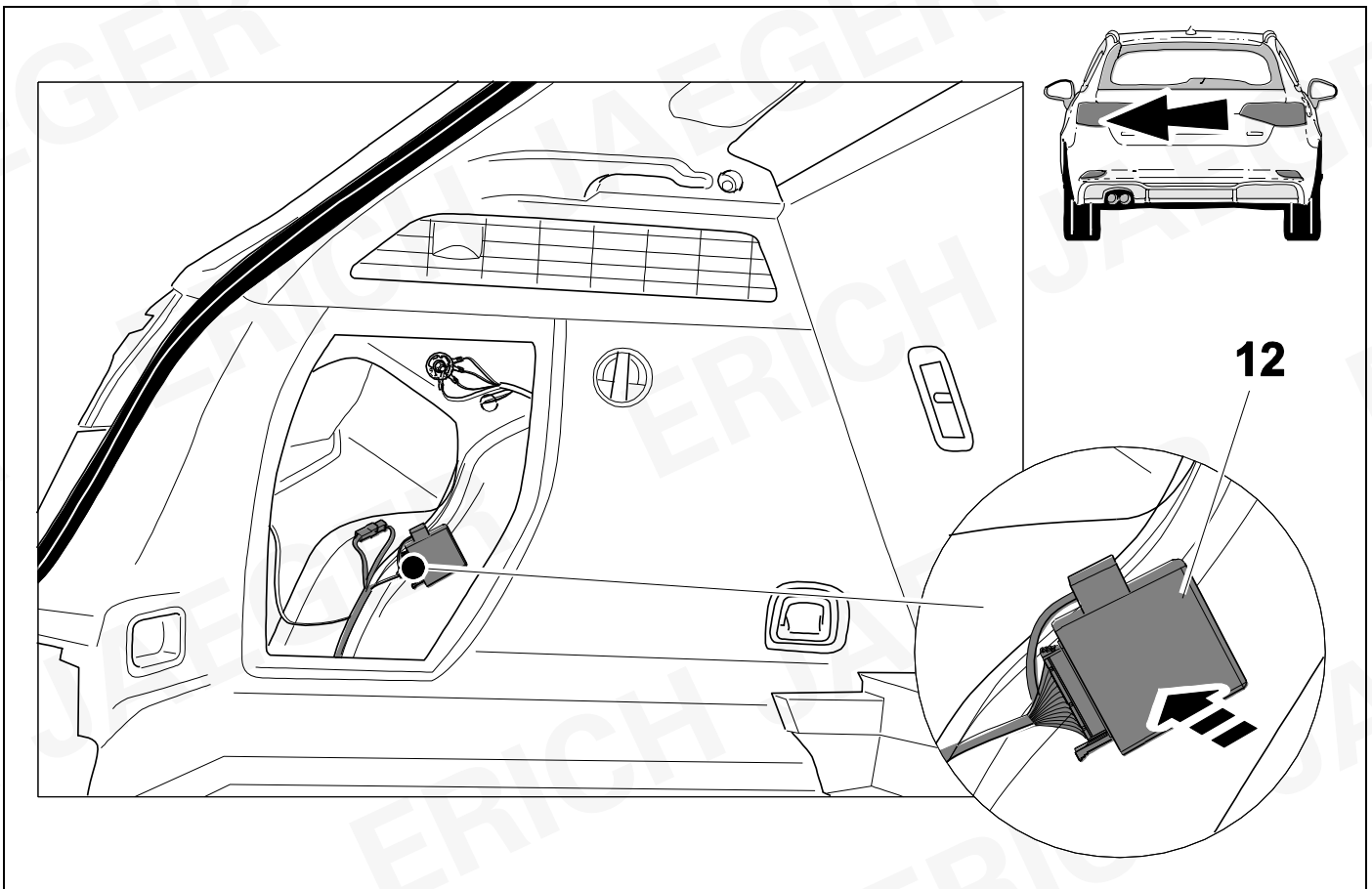

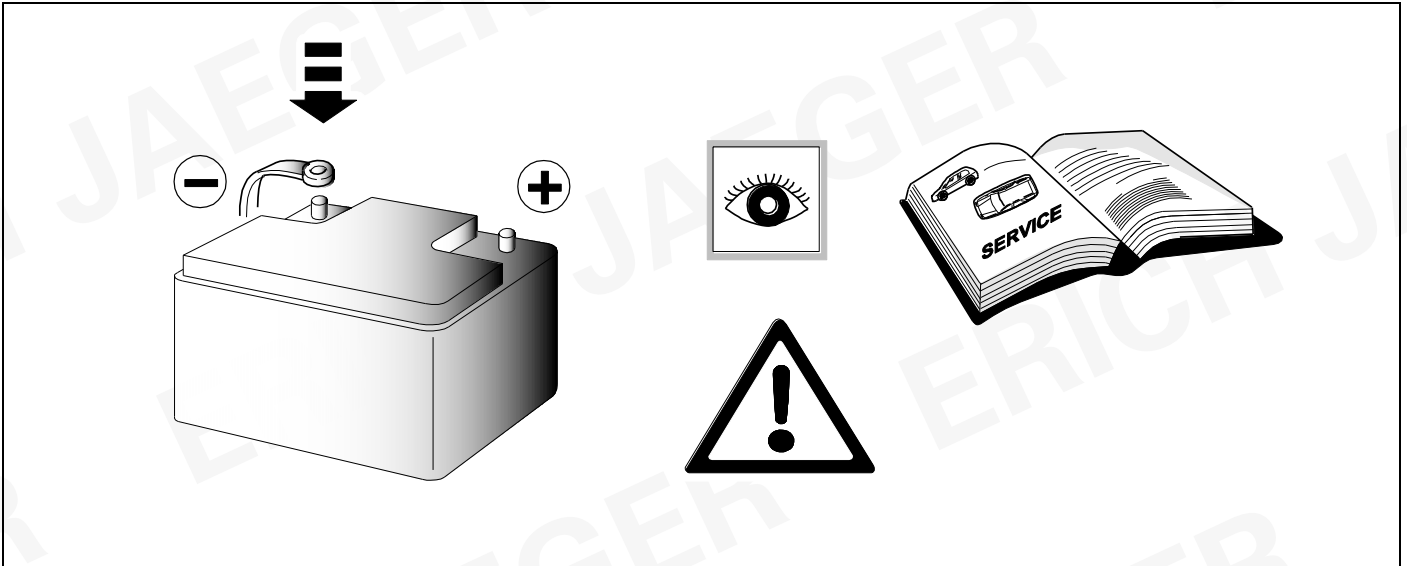

37

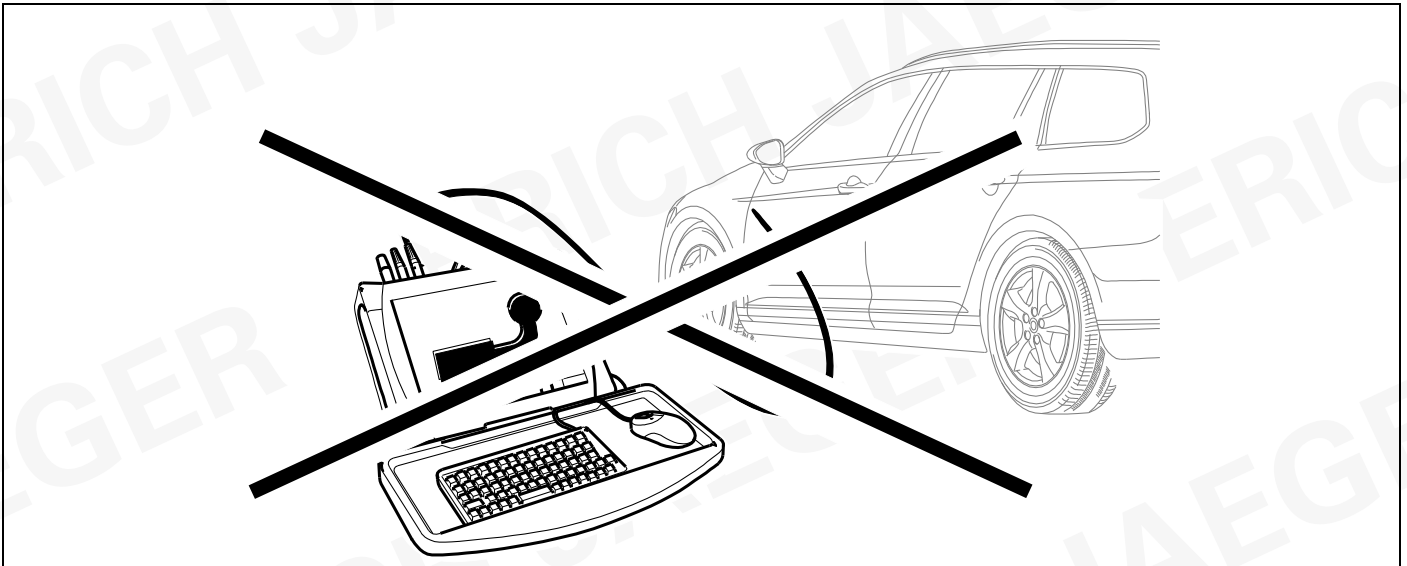

38

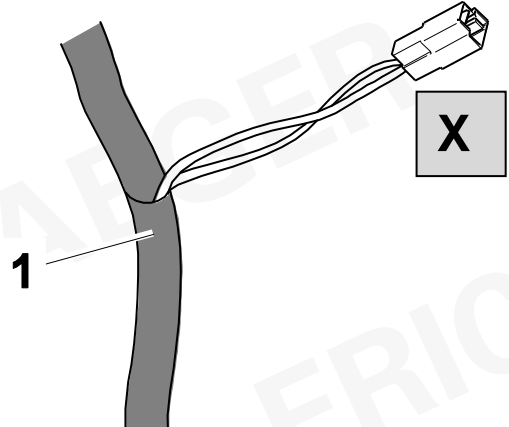
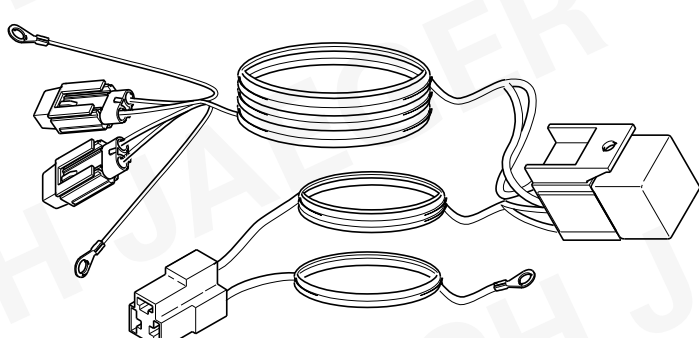

39 OPTIONAL

		ERICH JAEGER Artikelnummer: ERICH JAEGER part number:	<b>721074</b>
 <p>1</p>			

## 40 CHECK

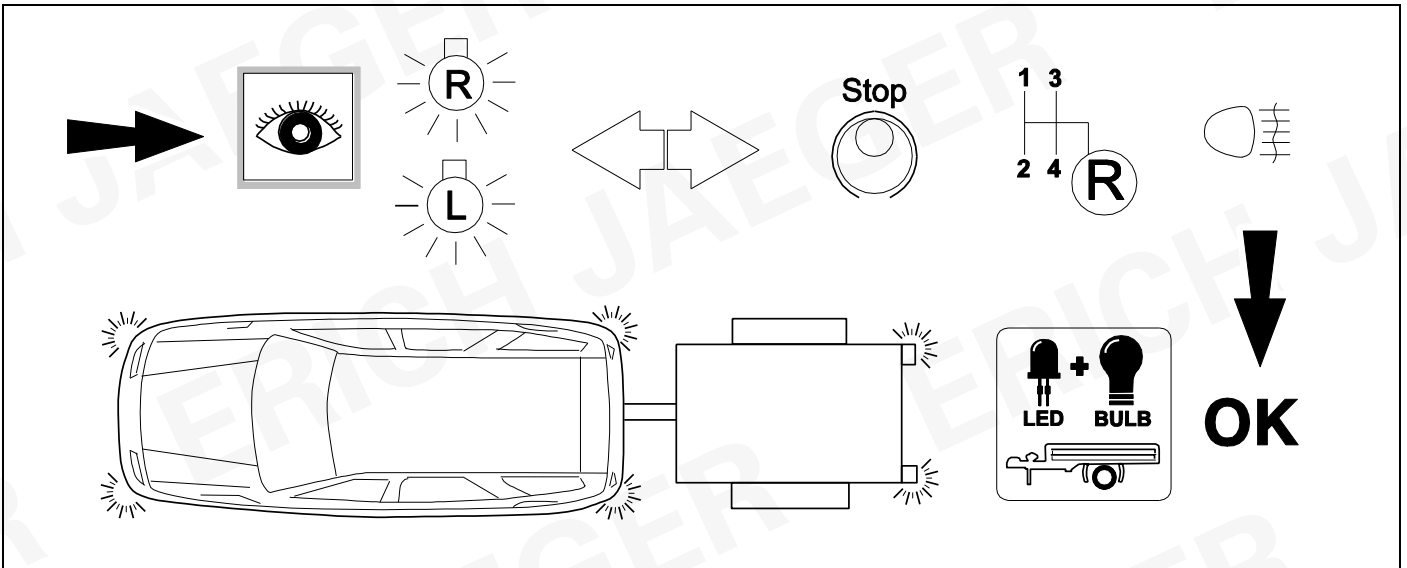

## 41 CHECK

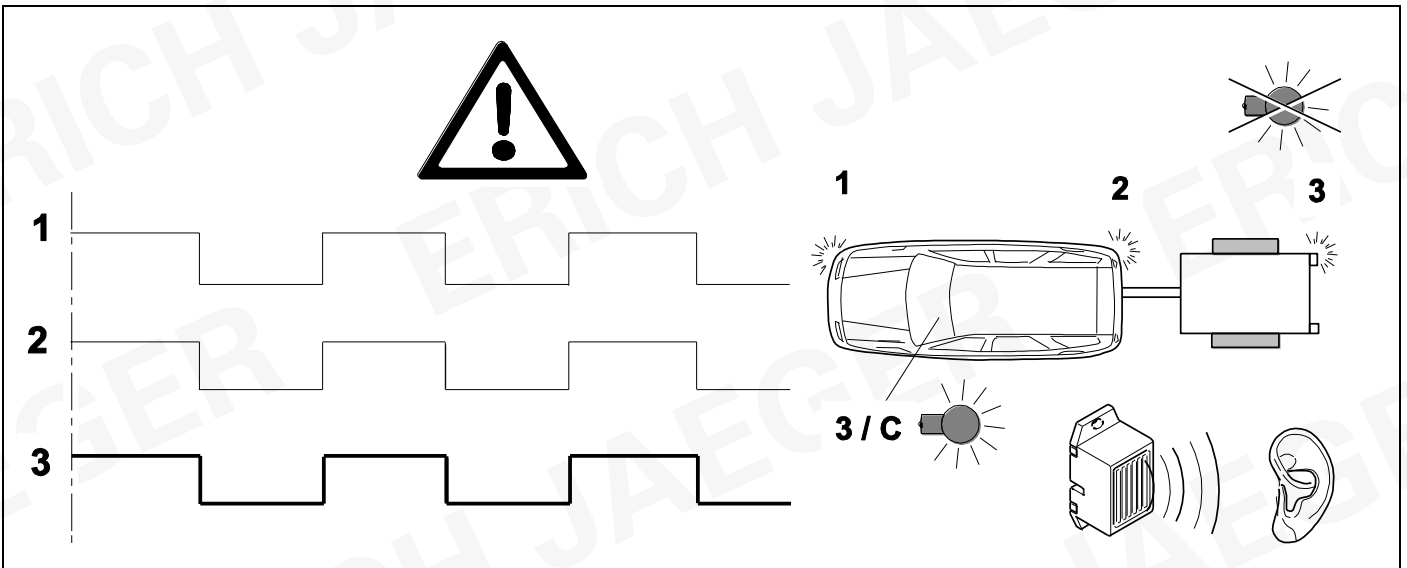

## 42 INFORMATION



18

+

19

+

23

+

24

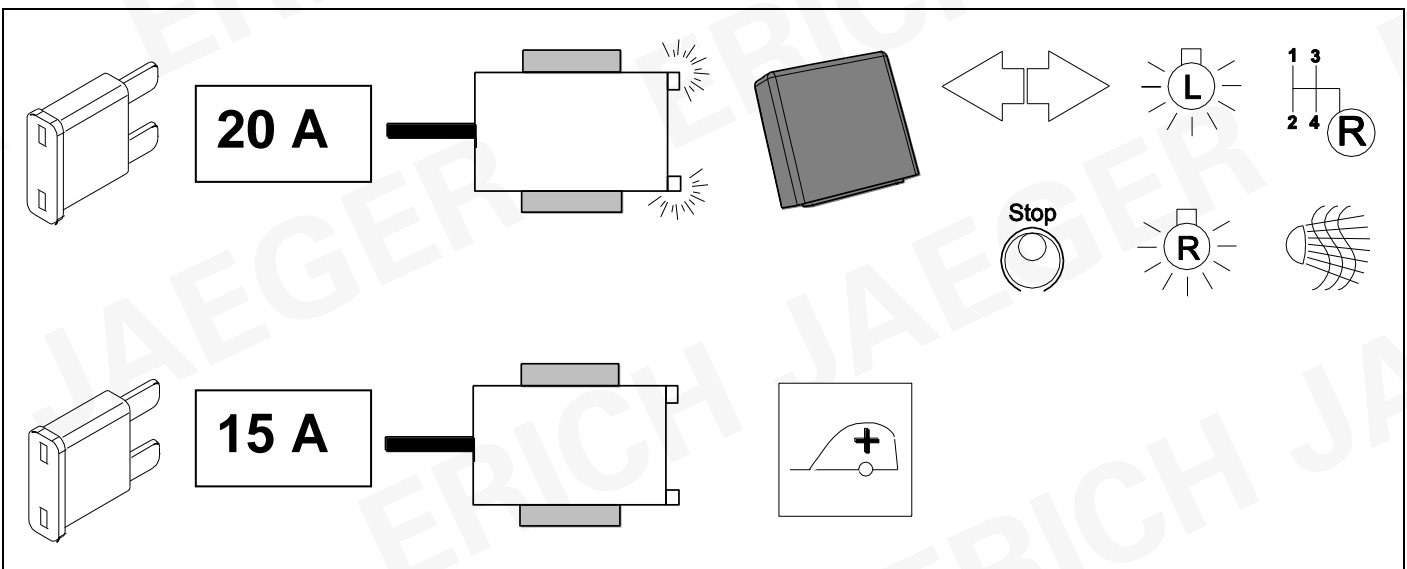

## OPTION vehicle coding



44



49

**! Achtung !**

Diese Kodierung kann eventuell nach einem Besuch bei einer autorisierten Werkstatt verloren gehen!

**! Attention !**

These codings may be lost after visiting an authorized workshop!

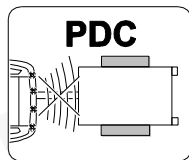
**PDC**

**TSP**  
Trailer  
Stability  
Program

**P**  
Trailer  
Assistent



## OPTION vehicle coding

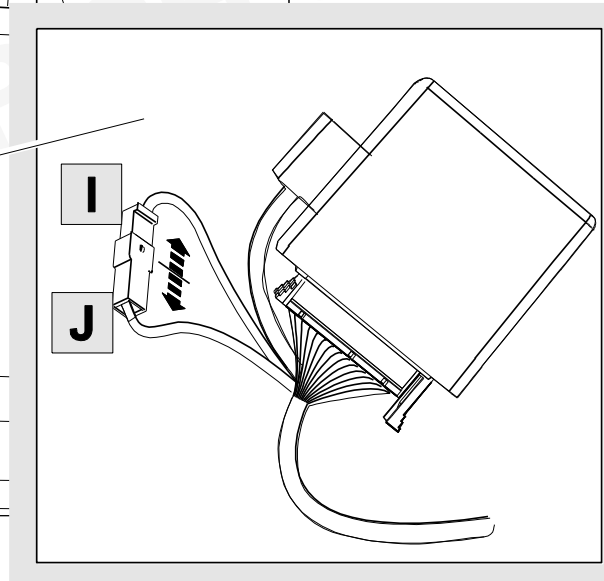
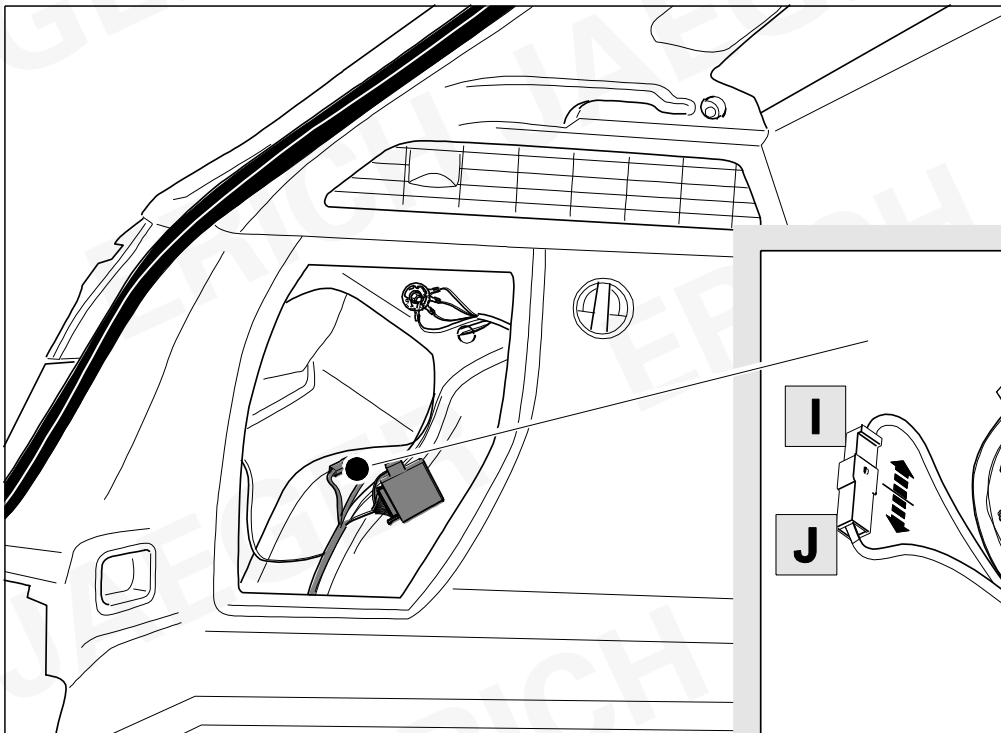
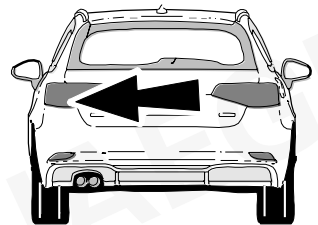

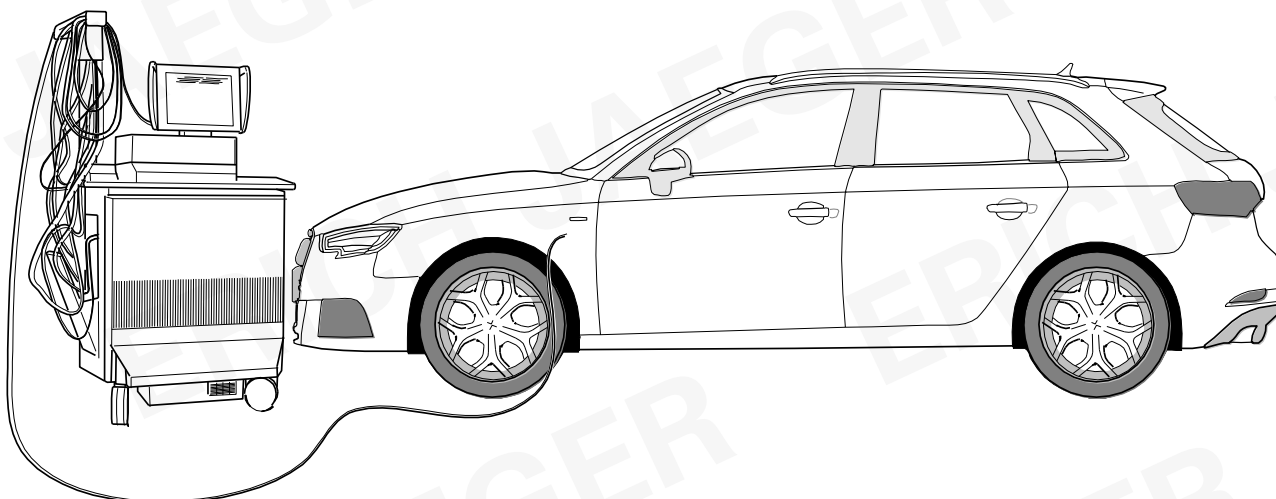

**D****Codierung bitte wie folgt durchführen:**

- Alternative Diagnosedienstleister bzw. Diagnosemethoden (lokal / offline) :
  - ODIS / VCDS
  - Hella Gutmann ( Seite 26 )
  - Autologic
  - Bosch / KTS
  - SP Diagnostic
  - SUN
  - Westfalia Auto Code
  - etc. pp.

**GB****Please effect coding as follows:**

- Alternative Diagnosis Services or diagnostic methods (local / offline) :
  - ODIS / VCDS
  - Hella Gutmann ( page 26 )
  - Autologic
  - Bosch / KTS
  - SP Diagnostic
  - SUN
  - Westfalia Auto Code
  - etc. pp.

**F****Veillez suivre le codage suivant:**

- Diagnostic services alternatives ou les méthodes de diagnostic (local/hors ligne) :
  - ODIS / VCDS
  - Hella Gutmann ( page 26 )
  - Autologic
  - Bosch / KTS
  - SP Diagnostic
  - SUN
  - Westfalia Auto Code
  - etc. pp.

**I****Favore codifica effettuate come segue:**

- -Alternativa Diagnosi Servizio o metodi diagnostici (locale/offline) :
  - ODIS / VCDS
  - Hella Gutmann ( pagina 26 )
  - Autologic
  - Bosch / KTS
  - SP Diagnostic
  - SUN
  - Westfalia Auto Code
  - etc. pp.

**E****Por favor de codificación lleva a cabo como sigue:**

- Servicio de Diagnóstico alternativa o métodos de diagnóstico (locales/ fuera de linea) :
  - ODIS / VCDS
  - Hella Gutmann ( pagina 26 )
  - Autologic
  - Bosch / KTS
  - SP Diagnostic
  - SUN
  - Westfalia Auto Code
  - etc. pp.

**NL****Gelieve codering ais volgt ultgevoerd:**

- Alternatief Diagnose Dienst of diagnostische methoden (lokale/offline) :
  - ODIS / VCDS
  - Hella Gutmann ( page 26 )
  - Autologic
  - Bosch / KTS
  - SP Diagnostic
  - SUN
  - Westfalia Auto Code
  - etc. pp.

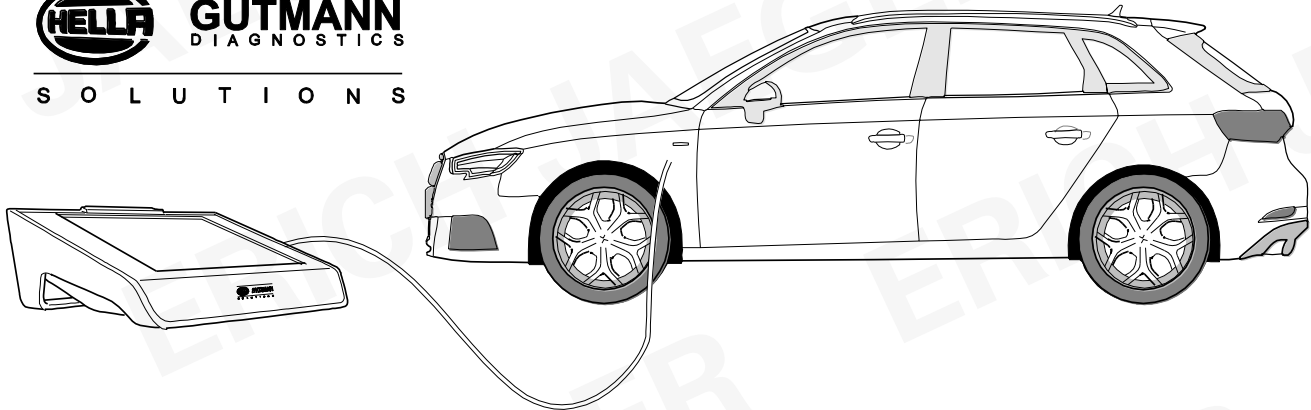

D	GB	F
<p><b>Die Aktivierung der Anhängerfunktionen muss wie folgt durchgeführt werden:</b></p> <ol style="list-style-type: none"> <li>1. Fahrzeugauswahl</li> <li>2. Zu Diagnose – Codierung wechseln</li> <li>3. Anhängerkupplung de-/aktivieren</li> <li>4. Diagnose Interface Bus auswählen</li> <li>5. Anleitung folgen</li> </ol> <p><b>Fahrzeuge mit Assistenzsystemen</b></p> <ol style="list-style-type: none"> <li>6. AHK an Assistenzsysteme anpassen ausführen</li> <li>7. Anleitung folgen</li> <li>8. Diagnose</li> <li>9. Fehlerspeicher auslesen, ggf. löschen</li> <li>10. Fertig</li> </ol>	<p><b>The activation of the trailer functions must be performed:</b></p> <ol style="list-style-type: none"> <li>1. Vehicle selection</li> <li>2. switch to diagnostics - coding</li> <li>3. Deactive/aktive trailer coupling</li> <li>4. Select diagnostic interface Bus</li> <li>5. Follow instructions</li> </ol> <p><b>Vehicle with assistance systems</b></p> <ol style="list-style-type: none"> <li>6. perform adaptation of trailer coupling on assistance systems</li> <li>7. Follow instructions</li> <li>8. Diagnostics</li> <li>9. Read out error memory, delete if necessary</li> <li>10. Done</li> </ol>	<p><b>Pour activer l'attelage, procéder de la façon suivante:</b></p> <ol style="list-style-type: none"> <li>1. Choix véhicule</li> <li>2. Aller dans le diagnostic - codage</li> <li>3. Activer/désactiver le diagnostic</li> <li>4. Sélectionner le BUS d'interface de diagnostic</li> <li>5. Suivre les instructions</li> </ol> <p><b>Véhicules avec systèmes d'aide</b></p> <ol style="list-style-type: none"> <li>6. Effectuer une adaptation d'attelage aux systèmes d'aide</li> <li>7. Suivre les instructions</li> <li>8. Diagnostic</li> <li>9. Lire la mémoire de défaut et effacer les codes d'erreur éventuellement mémorisés</li> <li>10. Terminé</li> </ol>
I	E	NL
<p><b>Per attivare le funzioni del rimorchio, procedere nel modo seguente:</b></p> <ol style="list-style-type: none"> <li>1. Scelta vettura</li> <li>2. Passare alla Diagnosi - Codifica</li> <li>3. Attivare / disattivare il gancio di traino</li> <li>4. Selezionare il interfaccia di diagnosi</li> <li>5. Seguire le istruzioni</li> </ol> <p><b>Veicoli noc suster di assistenza</b></p> <ol style="list-style-type: none"> <li>6. adattare i suster installati</li> <li>7. Seguire le istruzioni</li> <li>8. Diagnosi</li> <li>9. Leggere la memoria guasti e cancellare, se necessario</li> <li>10. Fertig</li> </ol>	<p><b>La activación de las funciones de remolque debe la siguiente manera:</b></p> <ol style="list-style-type: none"> <li>1. Selección de vehículo</li> <li>2. Cambiar a diagnosis - Codificación</li> <li>3. Desactivar/ activar acoplamiento para remolque</li> <li>4. Selecciona diagnosis Interface Bus</li> <li>5. Seguir las instrucciones</li> </ol> <p><b>En vehículos noc sistemas de asistencia</b></p> <ol style="list-style-type: none"> <li>6. Ejecutar adaptación de acoplamiento para remolque a suster de asistencia</li> <li>7. Seguir las instrucciones</li> <li>8. Diagnosi</li> <li>9. Leer memoria de averias y borrarla si es necesario</li> <li>10. Listo</li> </ol>	<p><b>De activering van de aanhangerfuncties moet als volgt worden uitgevoerd:</b></p> <ol style="list-style-type: none"> <li>1. Voertuigselectie</li> <li>2. Ga naar Diagnose - Codering</li> <li>3. Aanhangwagenkoppeling deactiveren/activeren</li> <li>4. Diagnose interface bus selecteren</li> <li>5. Volg instructie op</li> </ol> <p><b>Bij voertuigen met assistentiesystemen</b></p> <ol style="list-style-type: none"> <li>6. „Aanhangwagenkoppeling aanpassen aan assistietiesystem“ uitvoeren</li> <li>7. Volg instructie op</li> <li>8. Diagnose</li> <li>9. Foutcodegeheugen uitlezen en indien nodig wissen</li> <li>10. Gereed</li> </ol>

# 47 CHECK

# OPTION vehicle coding

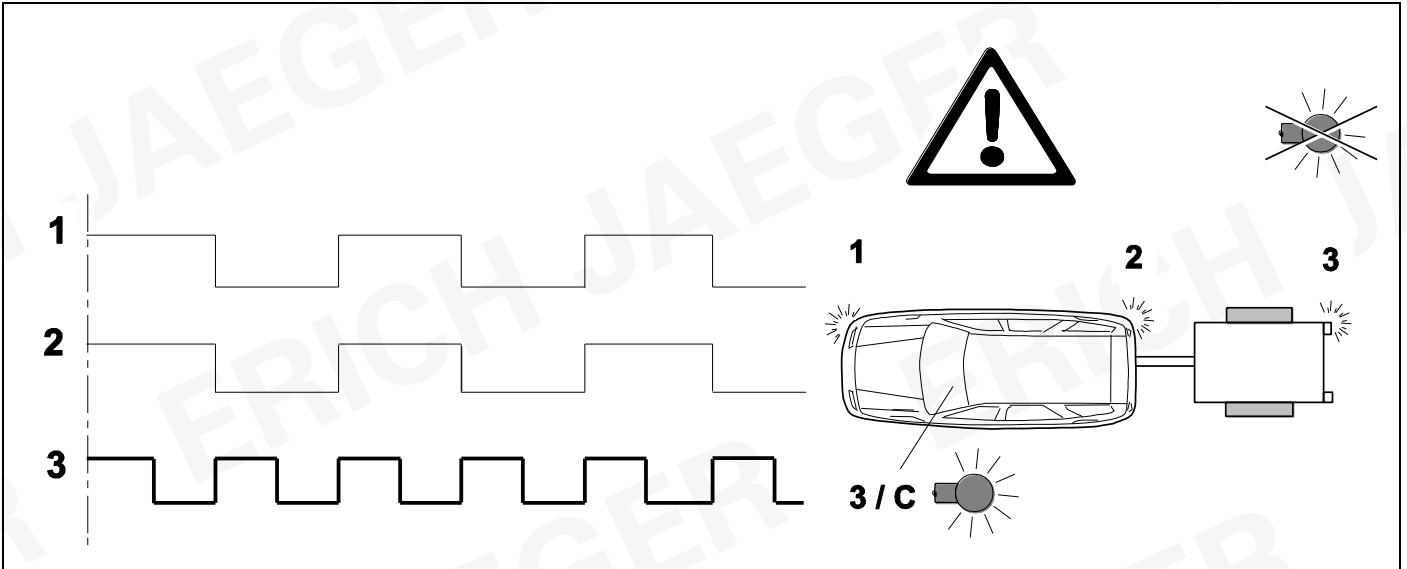

# 48

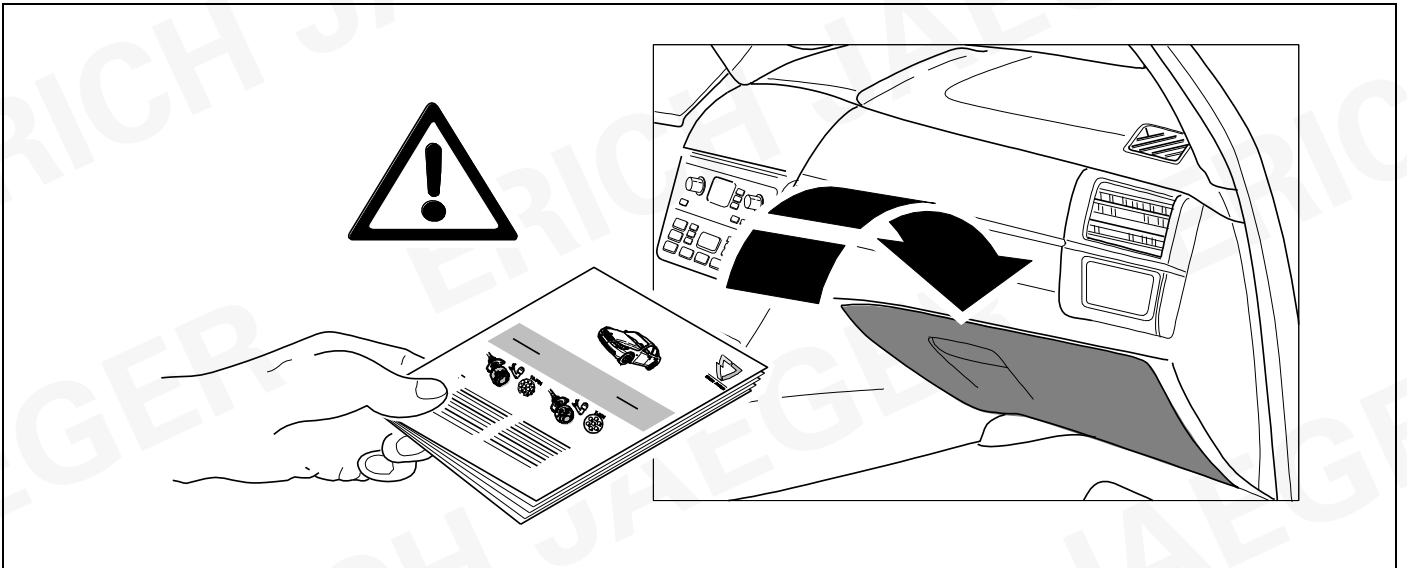

# 49

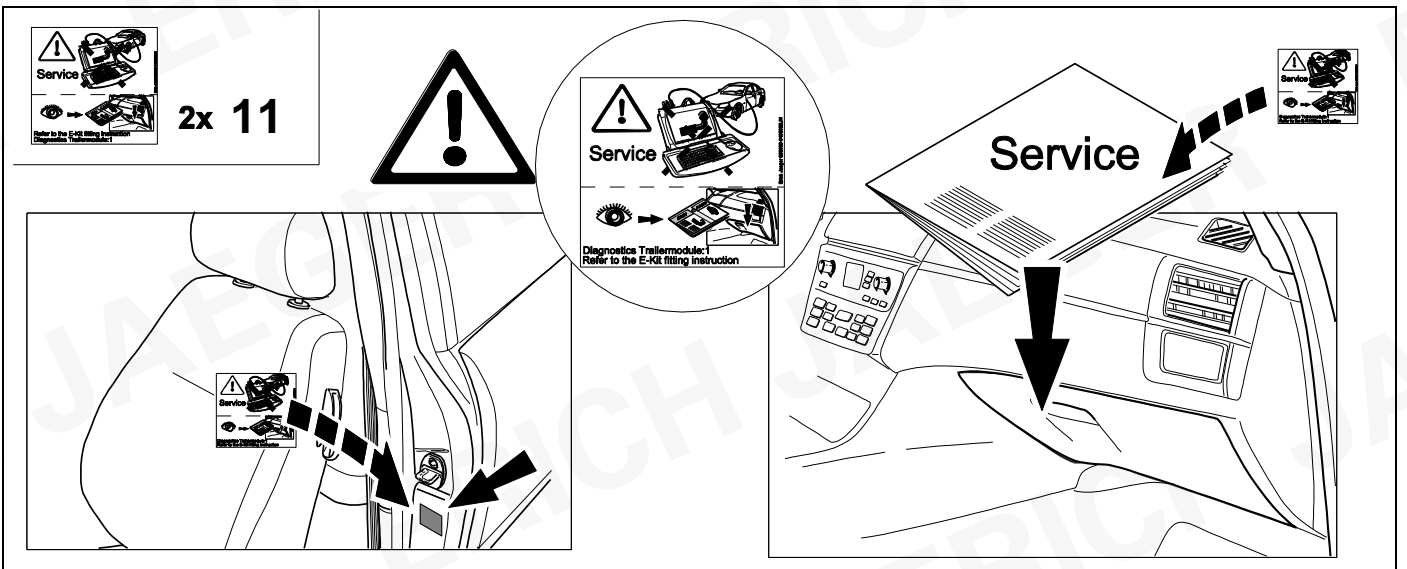

<b>D</b>	Änderungen bezüglich Konstruktion, Ausstattung Farbe sowie Irrtum vorbehalten. Angaben und Abbildungen unverbindlich	<b>PL</b>	Zastrzega się prawo do zmian dot. konstrukcji, wykończenia, kolorystyki oraz pomylek. Dane i ilustracje niewiążące.
<b>GB</b>	Subject to change in terms of construction, equipment and colour, and may contain errors. The information and illustrations are non-binding.	<b>TR</b>	Tasarım, donanım ve renk bakımından değişiklik yapma hakkı ve hata ve eksiklik mahfuzdur. Veriler ve resimler bağlayıcı değildir.
<b>F</b>	Sous réserve de modifications de la construction, de équipement, de la couleur et sous réserve d'erreurs. Les indications et les illustrations sont sans engagement.	<b>H</b>	A szerkezet, a kivitel és a szín változtatása, valamint a változások joga fenntartva. Az adatok és az ábrák nem kötelező érvényűek.
<b>NL</b>	Wijzigingen met betrekking tot constructie, uitvoering en kleur evenals vergissingen voorbehouden. Gegevens en afbeeldingen niet bindend.	<b>HR</b>	Pravo promjena u svezi konstrukcije, opreme, boje kao i zabune oridžavamo. Podaci i ilustracije su neobavezne.
<b>DK</b>	Ændringer med hensyn til konstruktion, udstyr, farver samt fejl forbeholdes. Oplysninger og illustrationer er uforpligtende.	<b>BUL</b>	Запазени права по отношение на конструкцията, обзавеждането, цвета и грешки. Данните и изображенията не са обвързващи.
<b>N</b>	Ændringer angående konstruksjon, utstyr, farge og feiltagelse forbeholdes. Oplysninger og illustrasjoner uforbindtlig.	<b>RO</b>	Ne rezervăm dreptul unor modificări ale construcției, dotării, culorii și dreptul la erori Datele indicate și imaginile sunt orientative.
<b>S</b>	Med reservation för ändringar vad det gäller konstruktion, utrustning, färg samt för misstag. Uppgifterna och bilderna är inte bindande.	<b>RU</b>	Права на внесение изменений относительно конструкции, оснащения, окраски, а также на ошибки сохраняются. Данные и иллюстрации имеют примерный характер.
<b>FIN</b>	Pidätämme oikeuden rakennetta, varustusta, väriä koskeviin sekä erehdyksestä johtuviin muutoksiin. Tiedot ja kuvat eivät ole sitovia.	<b>LT</b>	Pasiliekaama konstrukcijos, įrangos bei reikmenų, spalvos pakeitimų ir klaidų teisė. Duomenys ir iliustracijos neįpareigojantys.
<b>I</b>	Con riserva di modifiche relative a progettazione, dotazione, colore ed errori. Le indicazioni e figure sono fornite senza impegno.	<b>LV</b>	Tiek paturētas tiesības uz konstrukcijas, iekārtu, krāsu izmaiņām, kā arī kļūdīšanās. Dati un attēli bez saistībām.
<b>E</b>	Reservadas las modificaciones respecto a diseño, equipamiento, color, así como error. Indicaciones y figuras sin compromiso.	<b>EST</b>	Konstruksiooni, varustuse ja võervi osas muudatused ning eksimine lubatud. Andmed ja joonised on mittesiduvad.
<b>P</b>	Reservamos o direito de alterações relativamente ao desenho, equipamento, cor, bem como de erro. Os dados e as gravuras não implicam compromisso da nossa parte.	<b>SLO</b>	Zadržana pravica do sprememb glede konstrukcije, opreme, barve ter pomote. Podatki in slike so neobvezne.
<b>GR</b>	Διατηρώνουμε κάθε επιφύλαξη ως προς αλλαγές σε σχέση με κατασκευή, εξοπλισμό, διαρρύθμιση, χρωματισμούς και λάθη παραδρομής.	<b>SK</b>	Zmeny, ktoré sa týkajú konštrukcie, vybavenia, farby, ako aj omyly sú vyhradené. Údaje a zobrazenia sú nezáväzné.
<b>CZ</b>	Změny, týkající se konstrukce, vybavení, barvy, jakož i omyly jsou vyhrazeny. Údaje a vyobrazení jsou nezávazné.		

**ERICH JAEGER Artikelnummer:**  
**ERICH JAEGER part number:**

**311069**

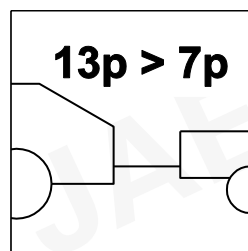
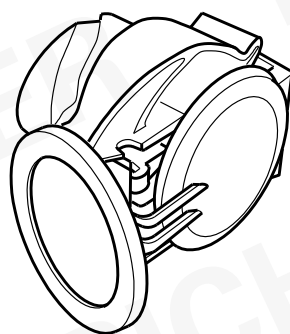

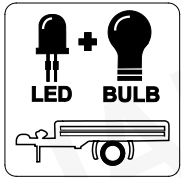

**Jaeger FLEX  
2in1**

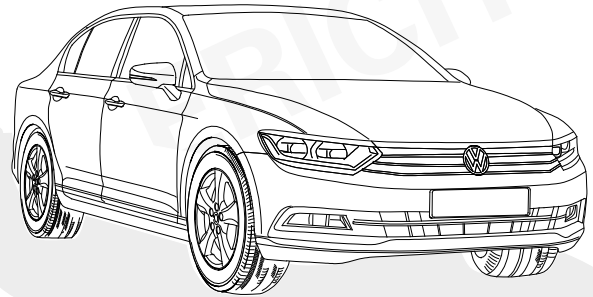
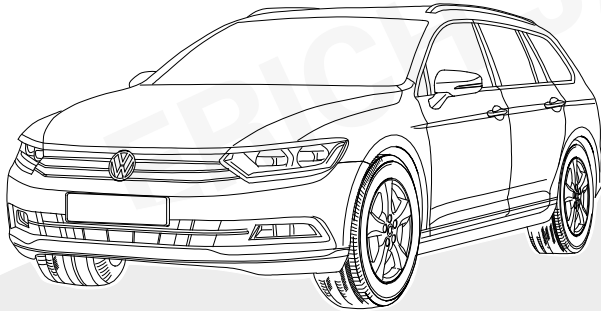

**VW Passat B8 Variant**  
**VW Passat B8 Limousine**

**11/14 >>**

**11/14 >>**

**748343**

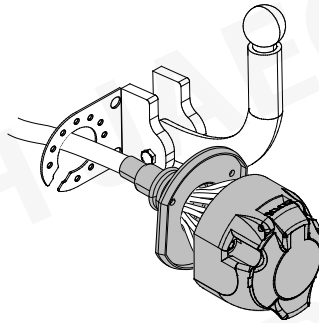

**13-PIN**

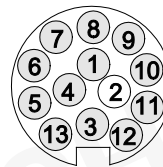

**ISO 11446**

- |  |   |
|--|---|
| <b>(D)</b> Einbauanleitung             | <b>(PL)</b> Instrukcja montażu                |
| <b>(GB)</b> Installation instructions  | <b>(TR)</b> Montaj talimatı                   |
| <b>(F)</b> Consignes de montage        | <b>(H)</b> Beépítési útmutató                 |
| <b>(NL)</b> Montagehandleiding         | <b>(HR)</b> Upute o ugradnji                  |
| <b>(DK)</b> Montagevejledning          | <b>(BUL)</b> Инструкция за монтаж             |
| <b>(N)</b> Monteringsinstruksjon       | <b>(RO)</b> Instrucțiuni de montaj            |
| <b>(S)</b> Installationsanvisning      | <b>(RU)</b> Инструкция по монтажу и установке |
| <b>(FIN)</b> Asennusohje               | <b>(LT)</b> Montavimo informacija             |
| <b>(I)</b> Istruzioni per il montaggio | <b>(LV)</b> Iemontēšanas pamācība             |
| <b>(E)</b> Instrucciones de montaje    | <b>(EST)</b> Paigaldusjuhend                  |
| <b>(P)</b> Instruções de montagem      | <b>(SLO)</b> Navodilo za vgradnjo             |
| <b>(GR)</b> Οδηγίες εγκατάστασης       | <b>(SK)</b> Montážny návod                    |
| <b>(CZ)</b> Návod k montáži            |   |



# KIT

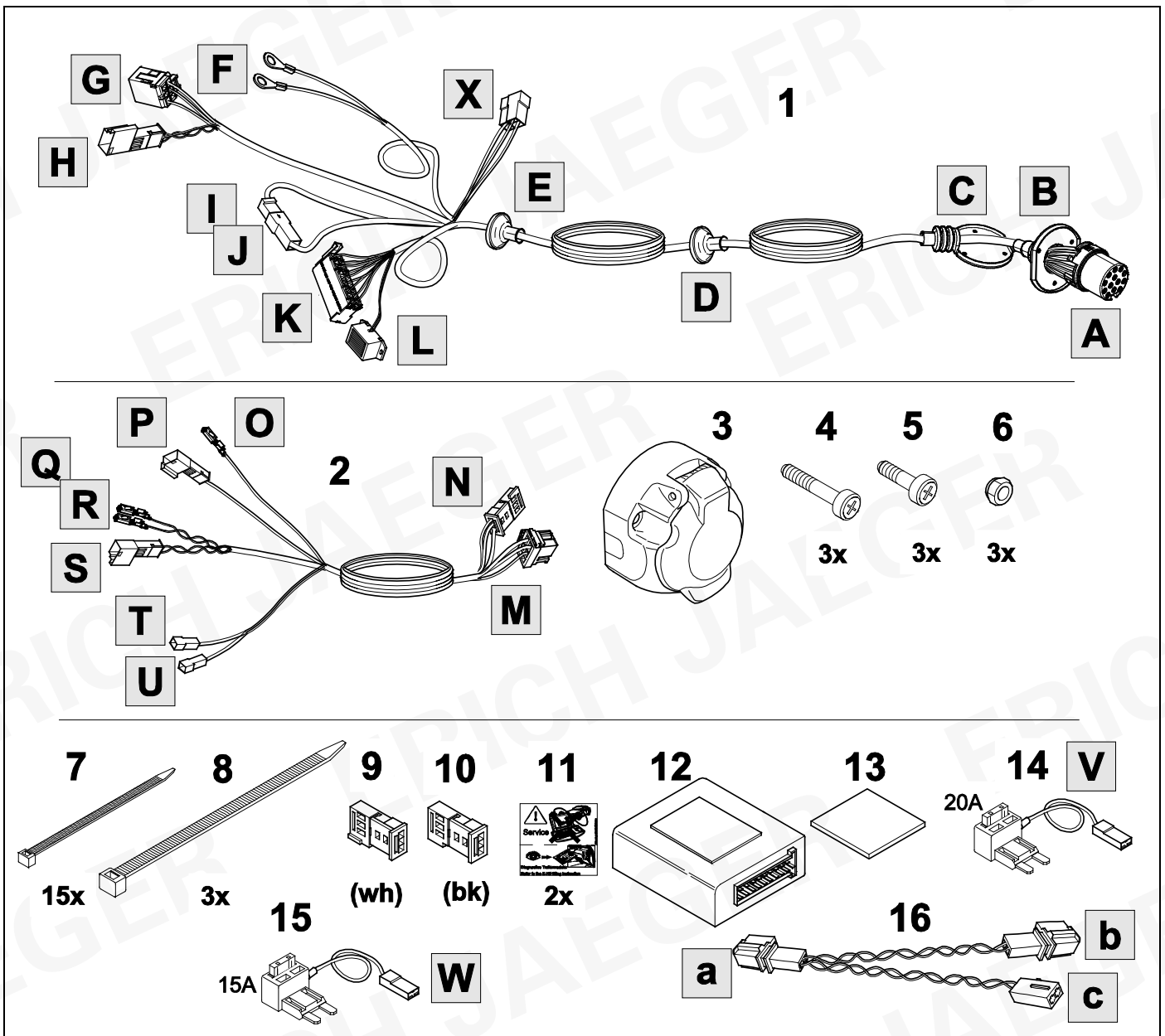

# TOOLS

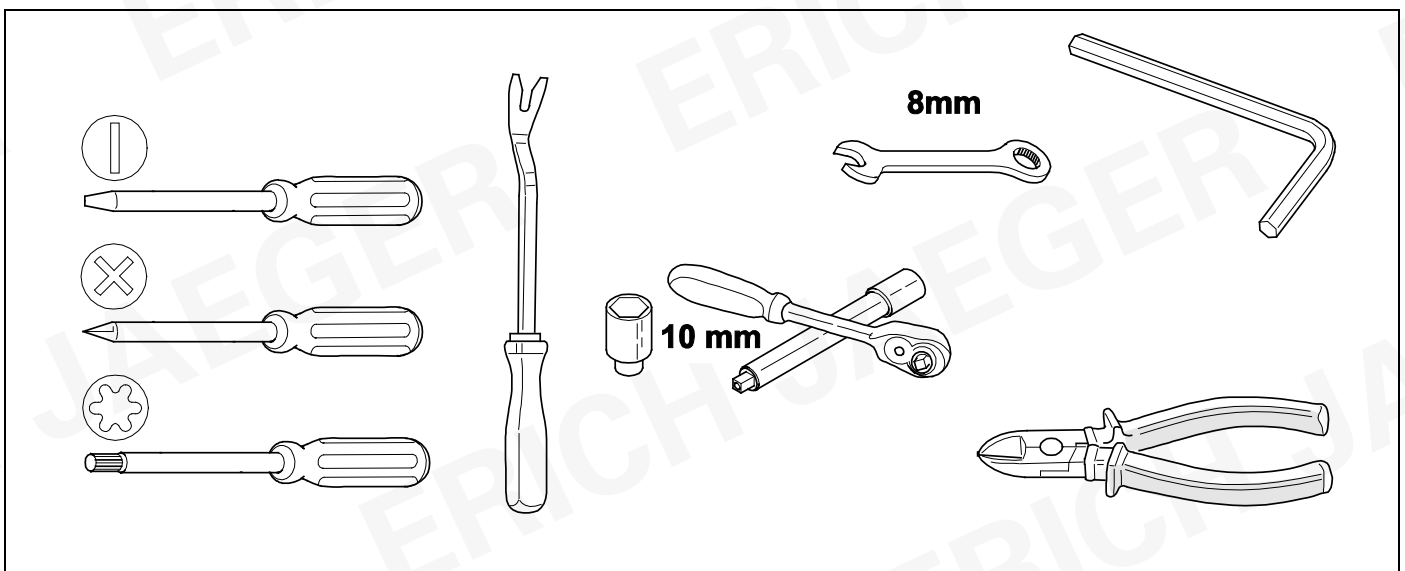

1

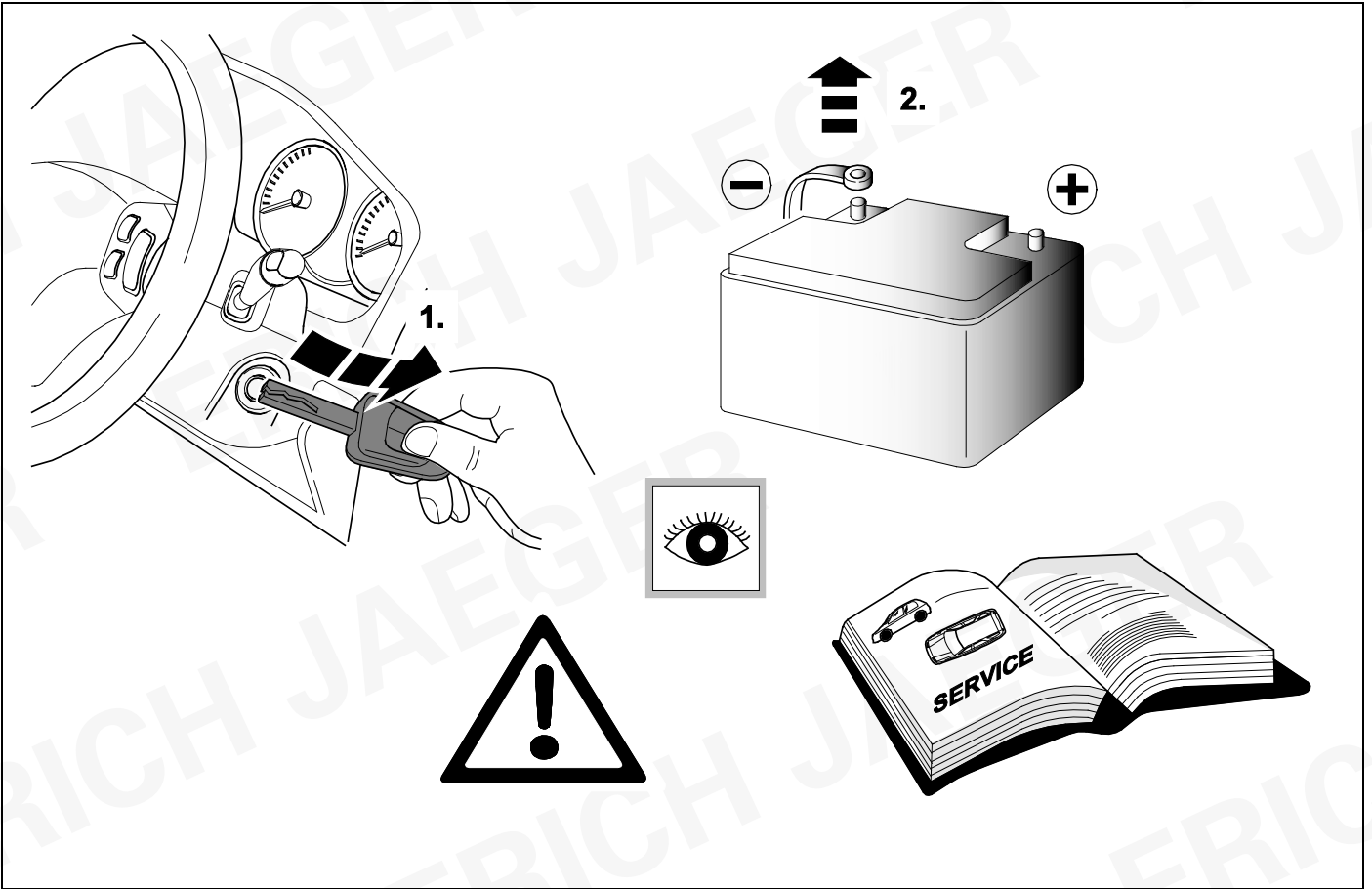

## 2 REMOVE

## VARIANT

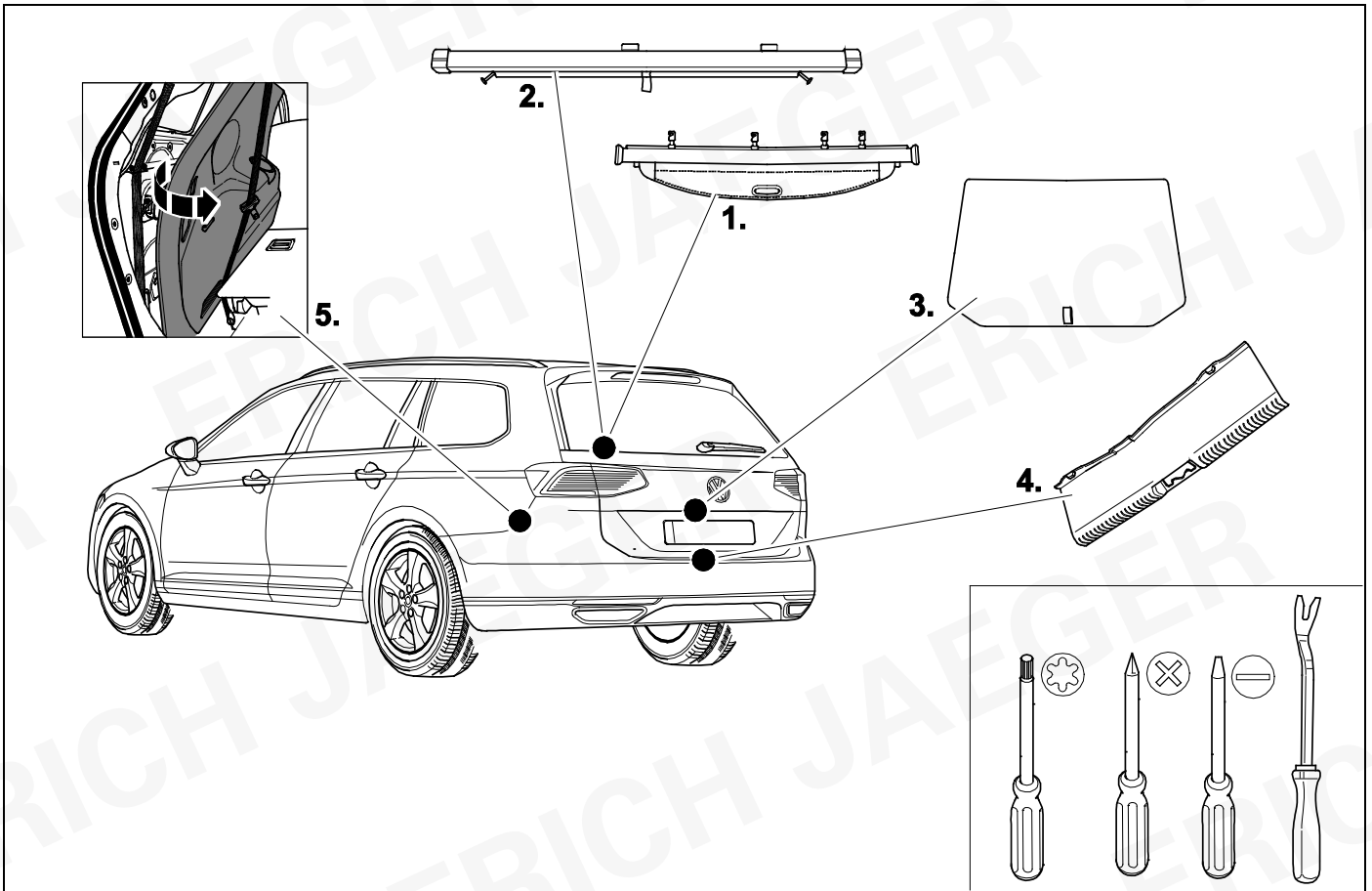

## 3 REMOVE

## LIMOUSINE

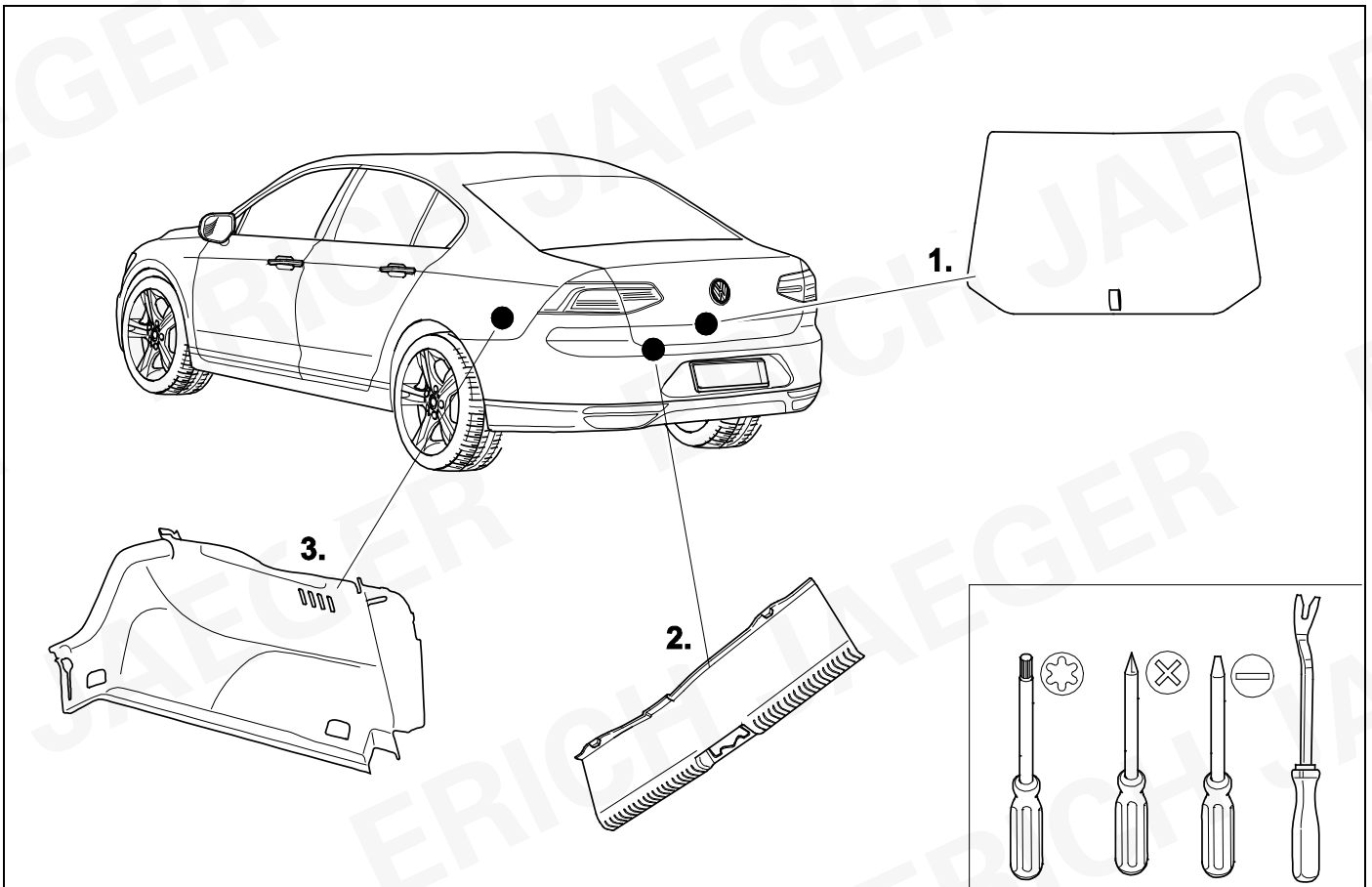



4

# VARIANT

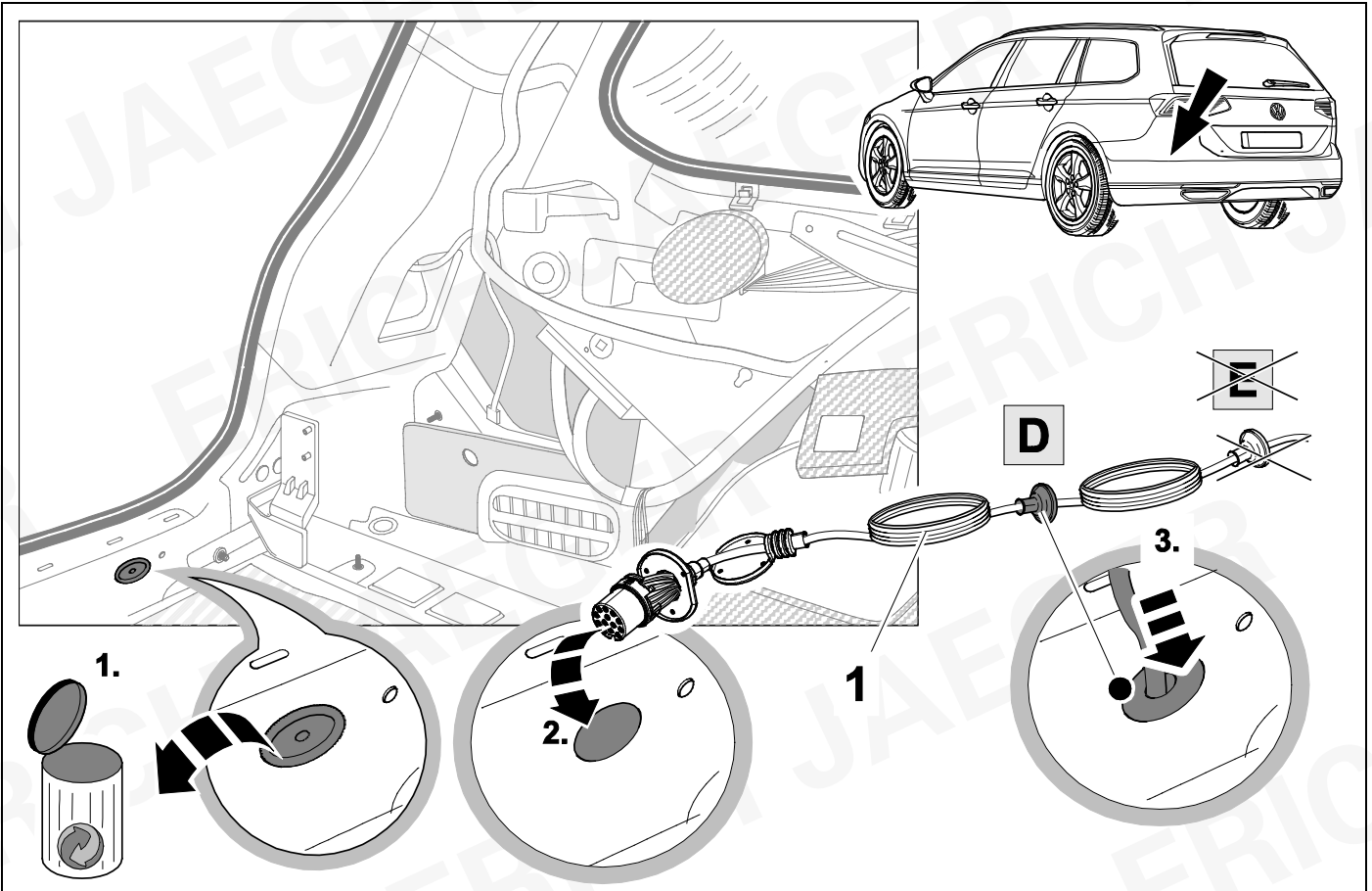

5

# LIMOUSINE

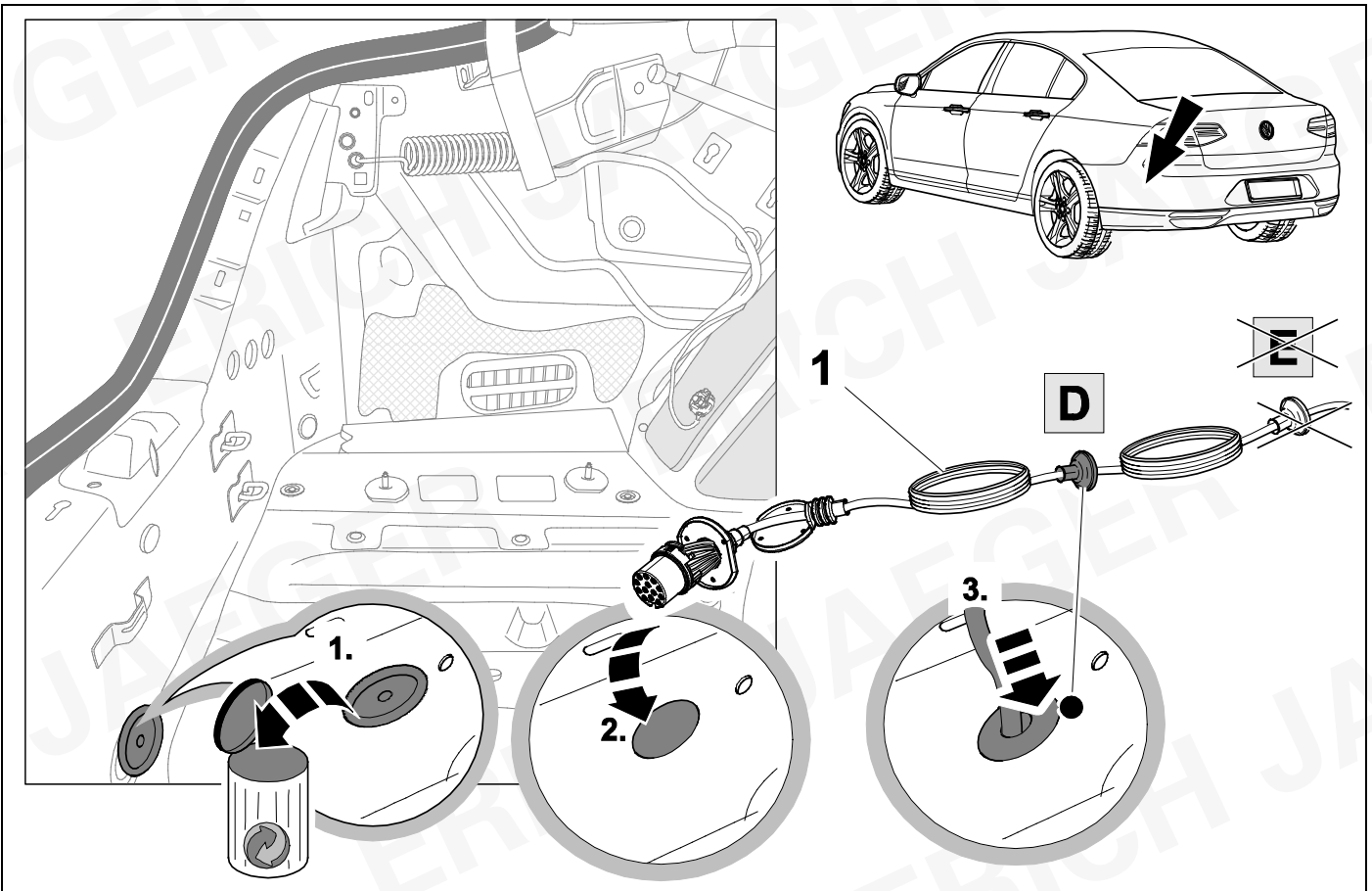

6

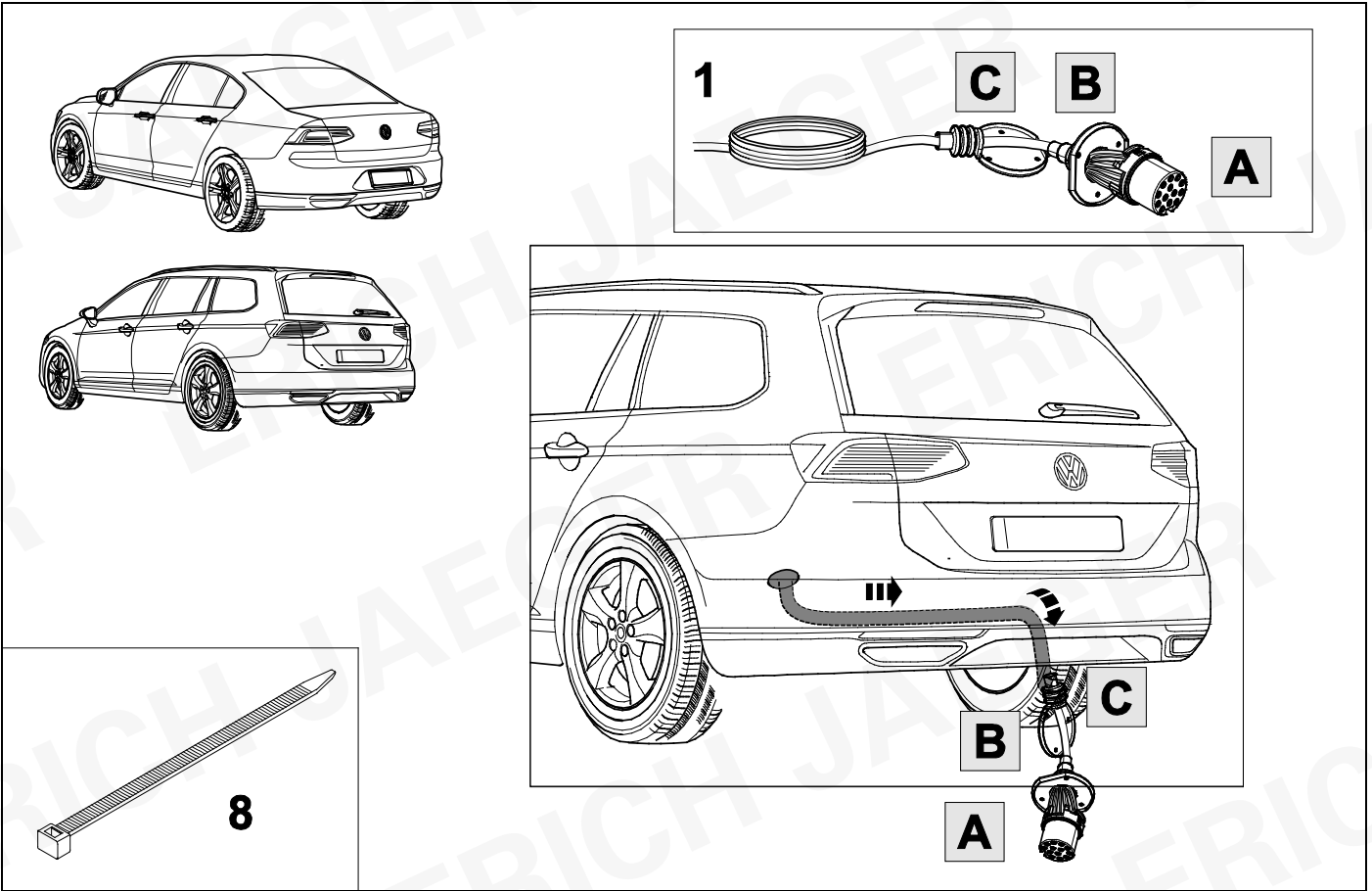

7

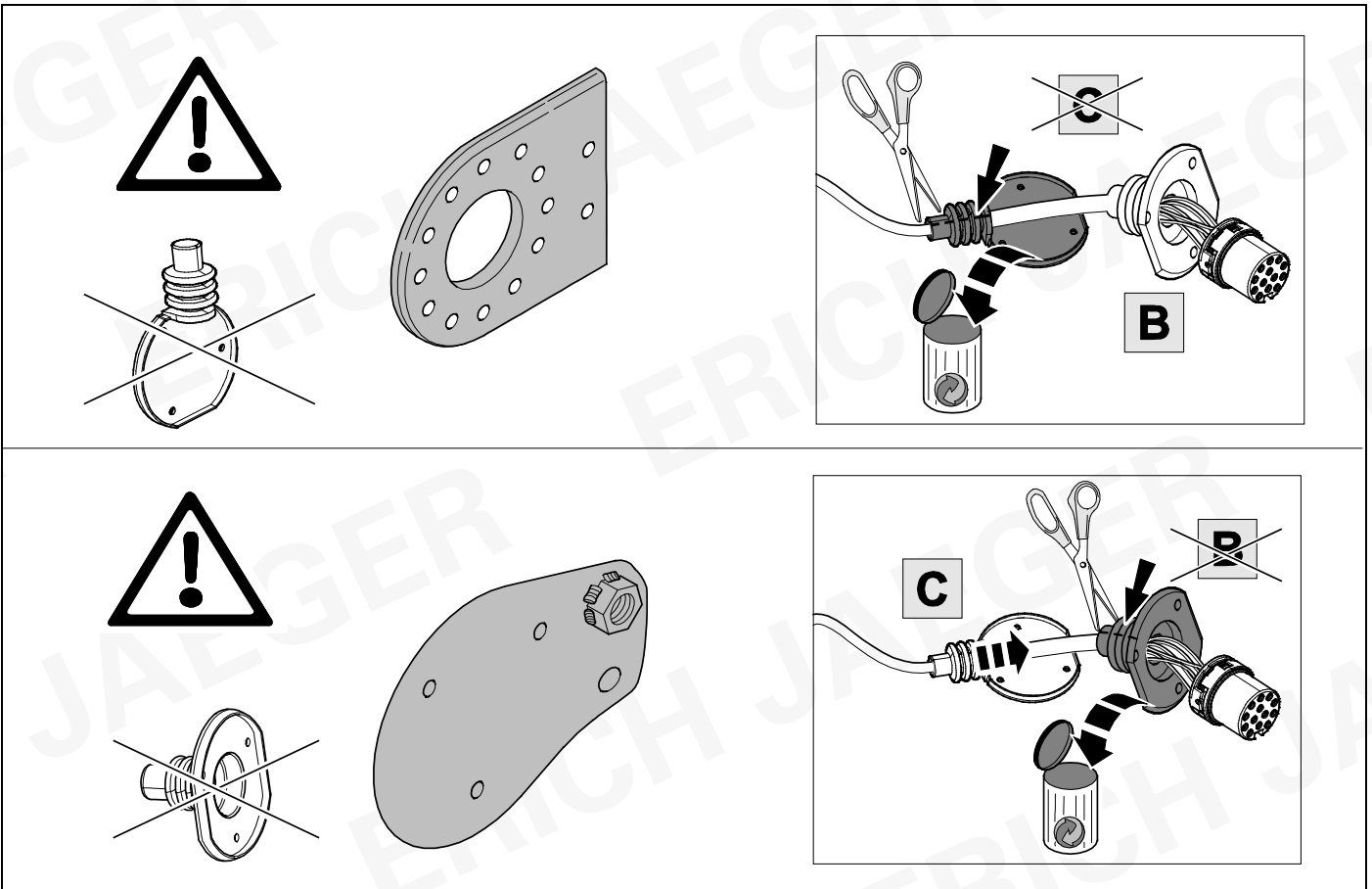

8



10

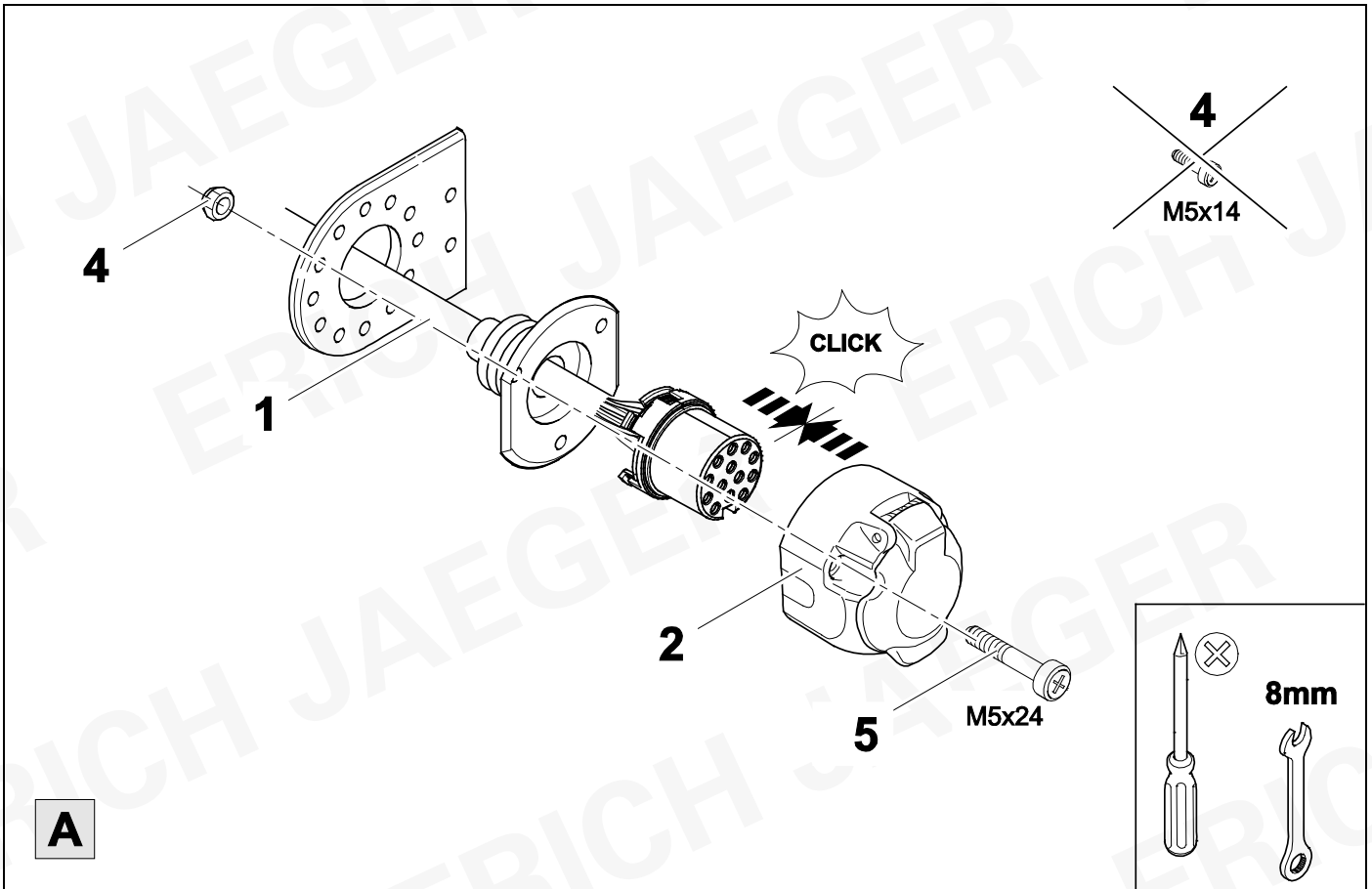

9



10

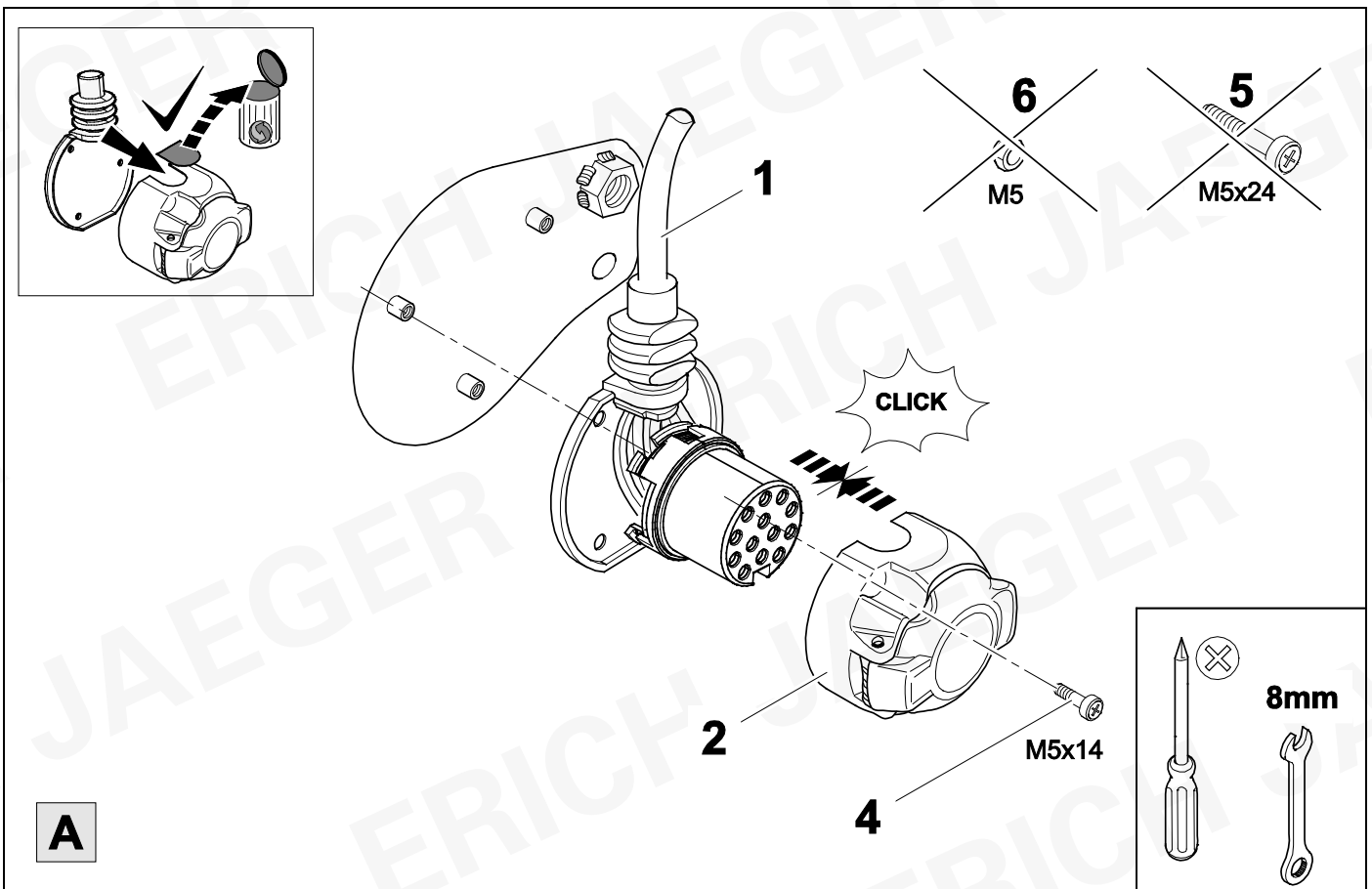

10



11

1	bk/wh		8	bu/rd	
2	gy		9	rd/bu	
3	wh/bn		10	ye	
4	bk/gn		11	bn/gn	
5	gy/rd		12	no	
6	bk/rd		13	bn	
7	gy/bk				

11	bk	wh	gy	gn	rd	bu	ye	bn	pu	or	no
<b>(D)</b>	schwarz	weiß	grau	grün	rot	blau	gelb	braun	violett	orange	nicht belegt
<b>(GB)</b>	black	white	grey	green	red	blue	yellow	brown	purple	orange	not occupied
<b>(F)</b>	noir	blanc	gris	vert	rouge	bleu	jaune	brun	violet	orange	inutilisé
<b>(NL)</b>	zwart	wit	grijs	groen	rood	blauw	geel	bruin	violet	oranje	niet aangesloten
<b>(DK)</b>	sort	hvid	grå	grøn	rød	blå	gul	brun	violet	orange	ikke anvendt
<b>(N)</b>	svart	hvit	grå	grønn	rød	blå	gul	brun	fiolett	oransje	ikke i bruk
<b>(S)</b>	svart	vit	grå	grön	röd	blå	gul	brun	violett	orange	ej använd
<b>(FIN)</b>	musta	valkoinen	harmaa	vihreä	punainen	sininen	keltainen	ruskea	violetti	oranssi	ei varattu
<b>(I)</b>	nero	bianco	grigio	verde	rosso	blu	giallo	marrone	viola	arancione	libero
<b>(E)</b>	negro	blanco	gris	verde	rojo	azul	amarillo	marrón	violeta	anaranja-do	no ocupado
<b>(P)</b>	preto	branco	cinzento	verde	vermelho	azul	amarelo	castanho	violeta	laranja	não ocupado
<b>(GR)</b>	μαύρος	λευκός	Γκρι	πράσινος	κόκκινος	μπλε	κίτρινος	καφέ	Μωβ	πορτοκαλί	δεν είναι κατ'επιτημένος
<b>(PL)</b>	czarny	biały	szaro	zielony	czerwony	niebiesko	żółty	brazowy	fioletowy	pomarańczowy	wolny
<b>(CZ)</b>	černý	bílý	šedý	zelený	červený	modrý	žlutý	hnědý	fialový	oranžový	neobsazen
<b>(TR)</b>	siyah	beyaz	gri	yeşil	kırmızı	mavi	sarı	kahverengi	mor	portakal rengi	boş
<b>(H)</b>	fekete	fehér	szürke	zöld	piros	kék	sárga	barna	ibolyakék	narancssárga	nem foglalt
<b>(HR)</b>	crno	bijelo	sivo	zeleno	crveno	plavo	zuto	smeđe	ljubičasto	narandžasto	nije zauzeto
<b>(BUL)</b>	черен	бял	сив	зелен	червен	син	жълт	кафяв	виолетов	оранжев	свободно
<b>(RO)</b>	negru	alb	gri	verde	roșu	albastru	galben	maro	violet	portocaliu	liber
<b>(RU)</b>	черный	белый	серый	зеленый	красный	голубой	жёлтый	коричневый	пурпурный	оранжевый	свободно
<b>(LT)</b>	juoda	balta	pilka	žalia	raudona	mėlyna	geltona	ruda	purpurinė	oranžinė	laisva
<b>(LV)</b>	melna	balta	pelēka	zaļa	sarkana	zila	dzeltena	brūna	purpur-sarkana	oranža	brīvs
<b>(EST)</b>	must	valge	hall	roheline	punane	sinine	kollane	pruun	purpur-punane	oraanž	vaba
<b>(SLO)</b>	črna	bela	siva	zelena	rdeča	modra	rumena	smeđ	vijoličast	oranžen	ni zasedeno
<b>(SK)</b>	čierny	biely	šedý	zelený	červený	modrý	žltý	hnědý	fialový	pomaraňový	neobsadený

12

# VARIANT

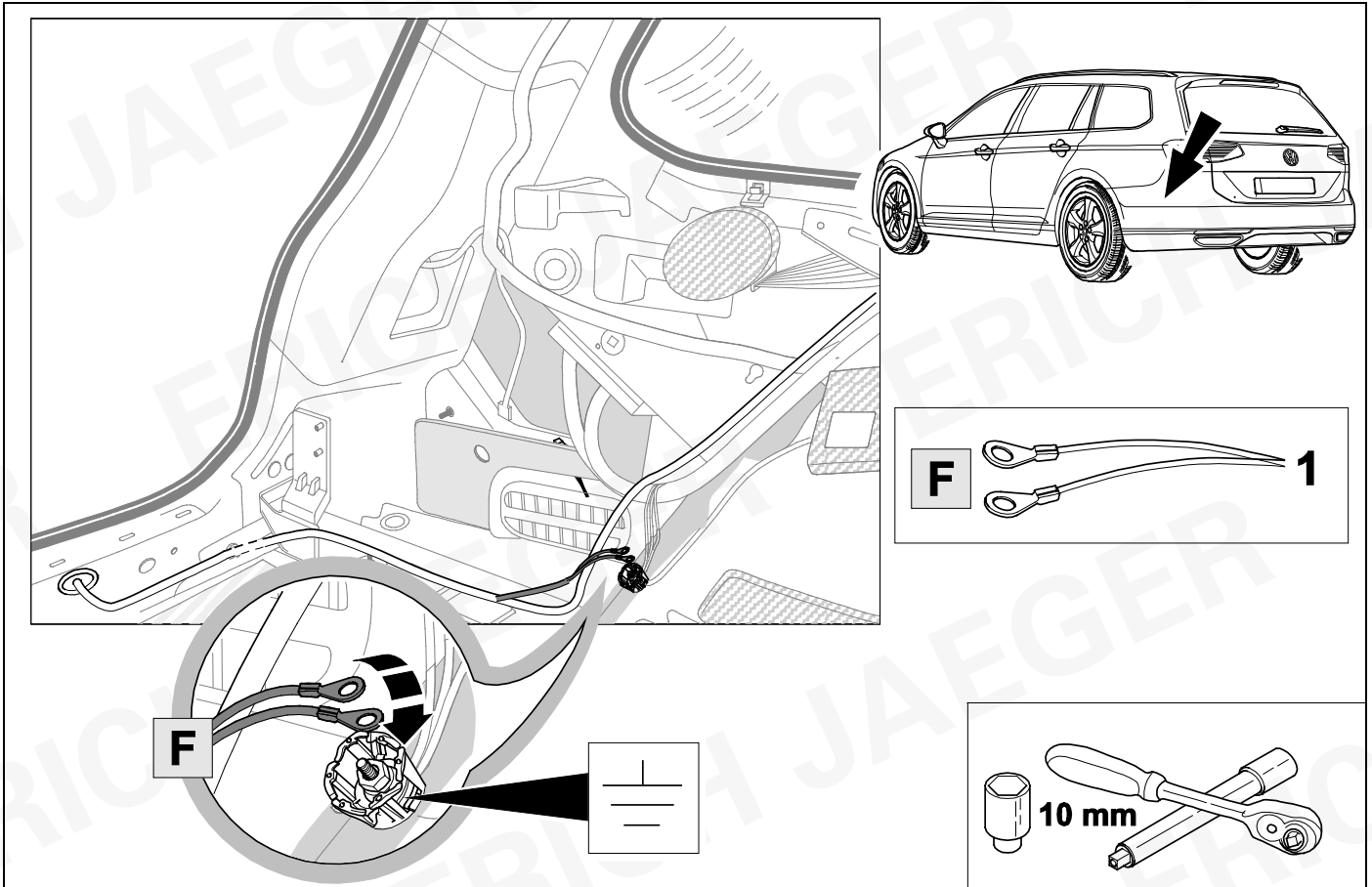

13

# LIMOUSINE

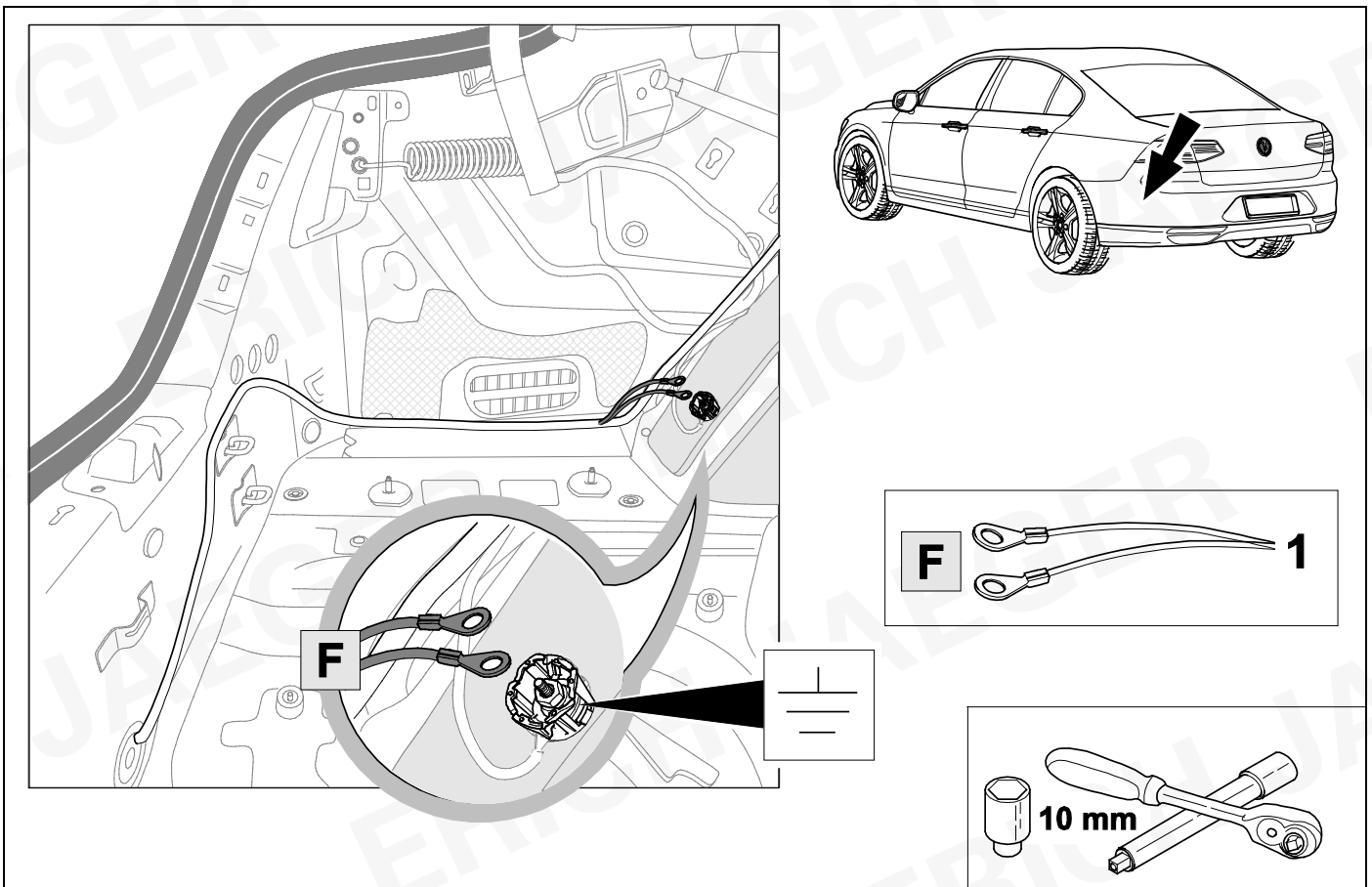

14



11

**Fahrzeuge mit Anhängervorbereitung**  
**Vehicles with trailer preparation**

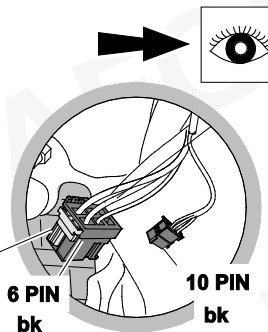
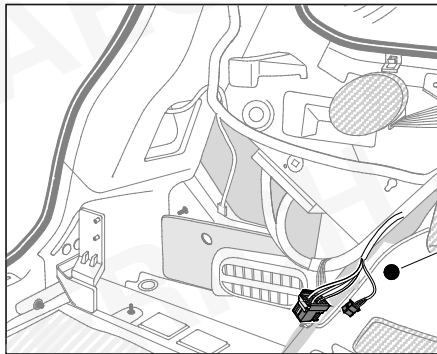

**OPTION 1**

15



21

38



55

**Fahrzeuge ohne Anhängervorbereitung**  
**Vehicles without trailer preparation**

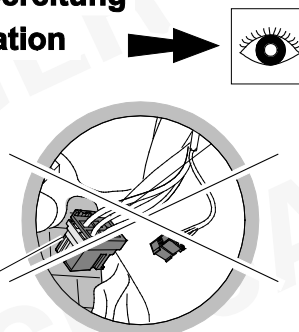
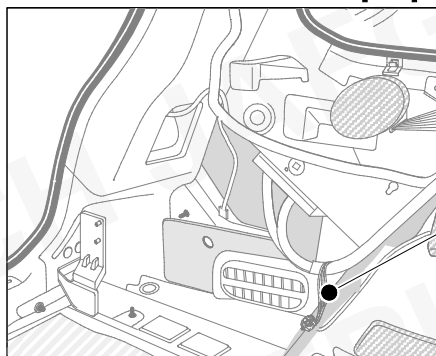

**OPTION 2**

23



55

15



11

**OPTION 1**

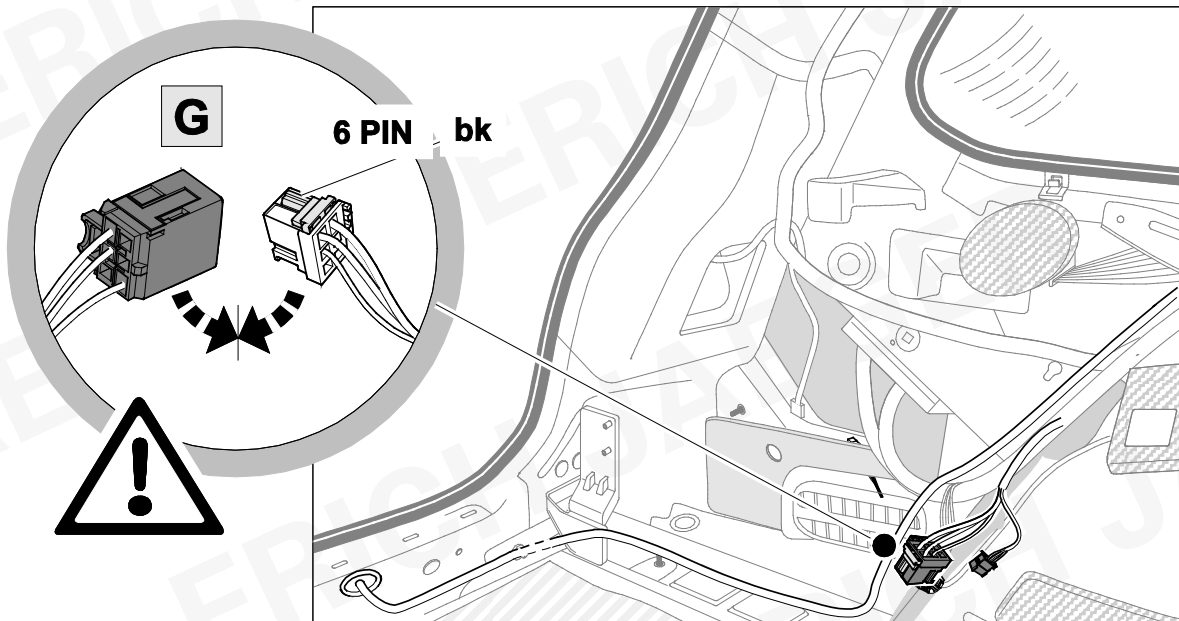
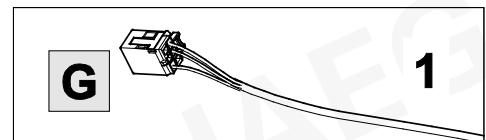
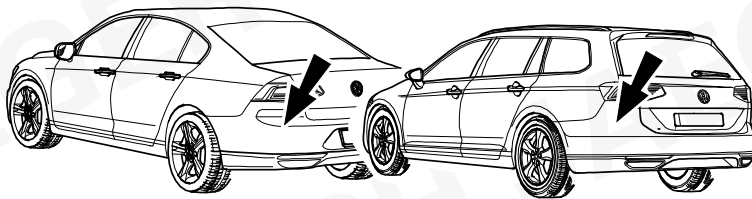

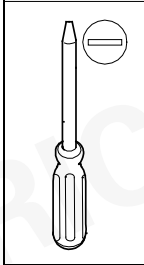
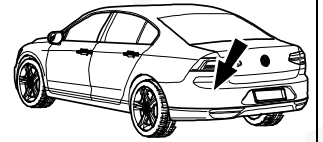
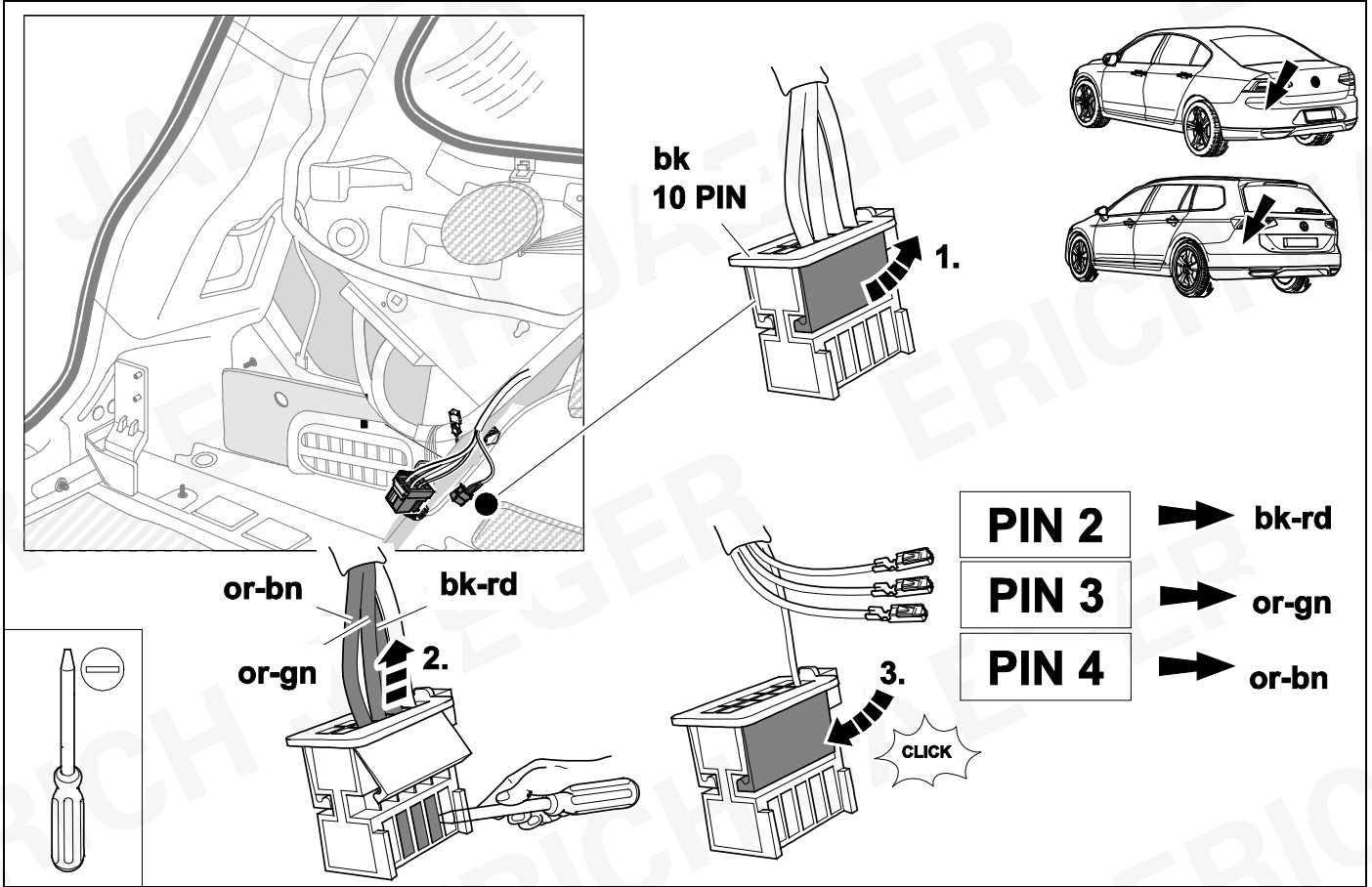

17



11

OPTION 1

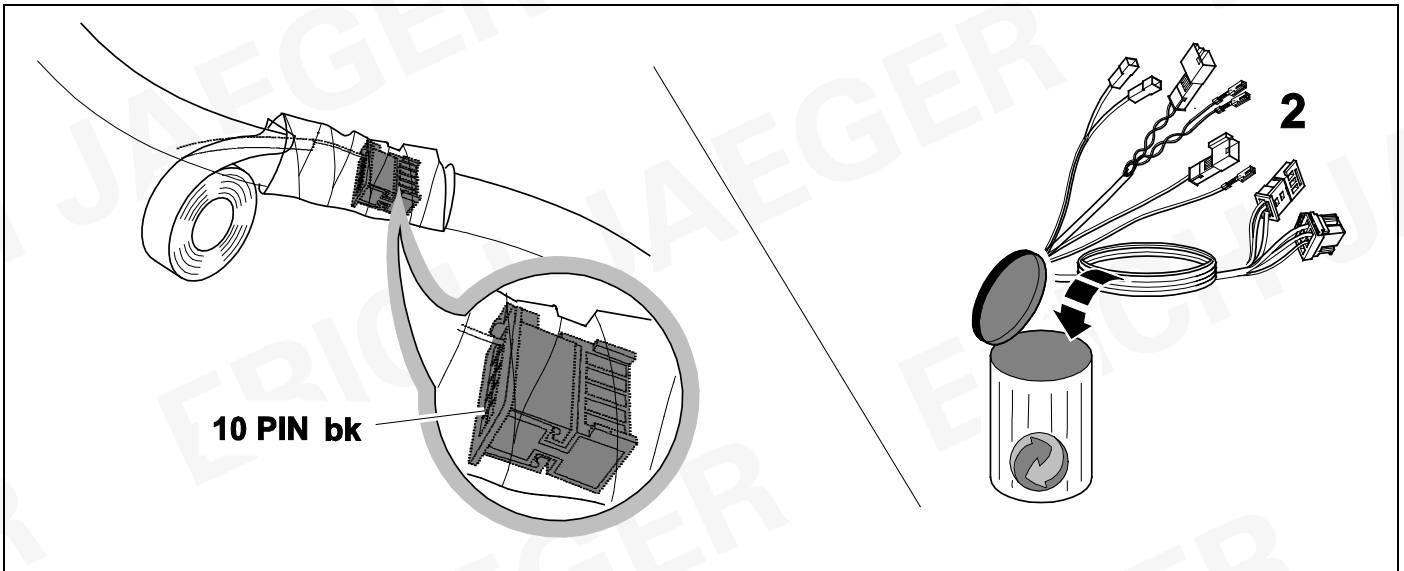

18



11

OPTION 1

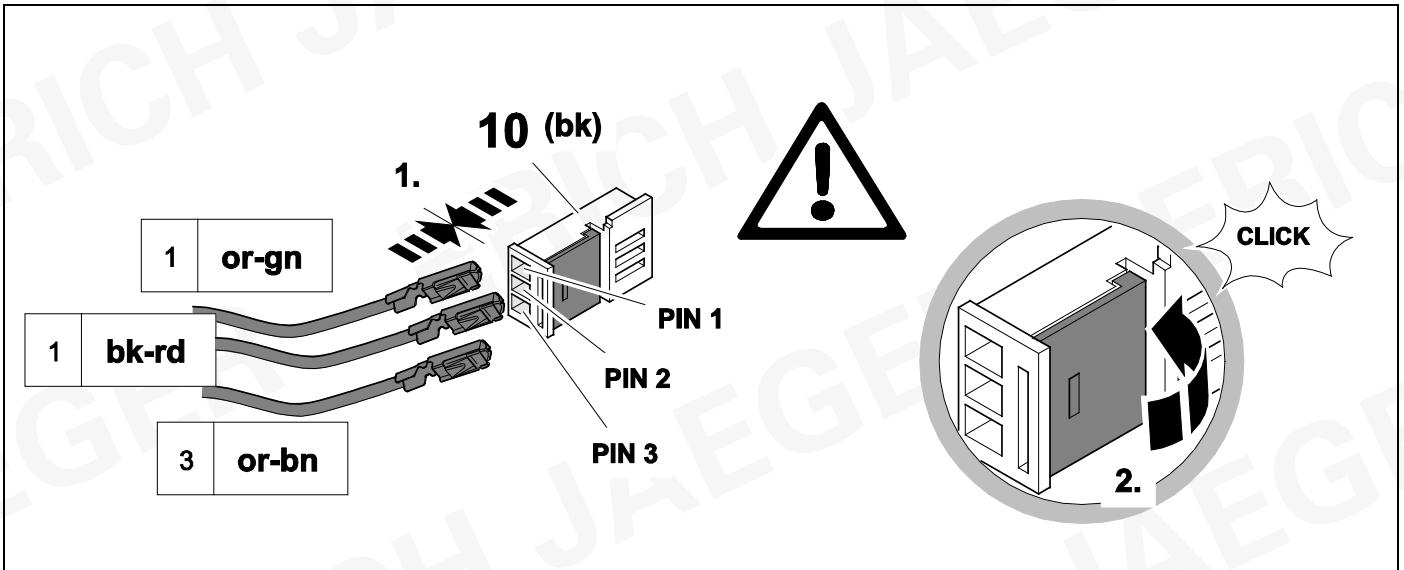

19



11

OPTION 1

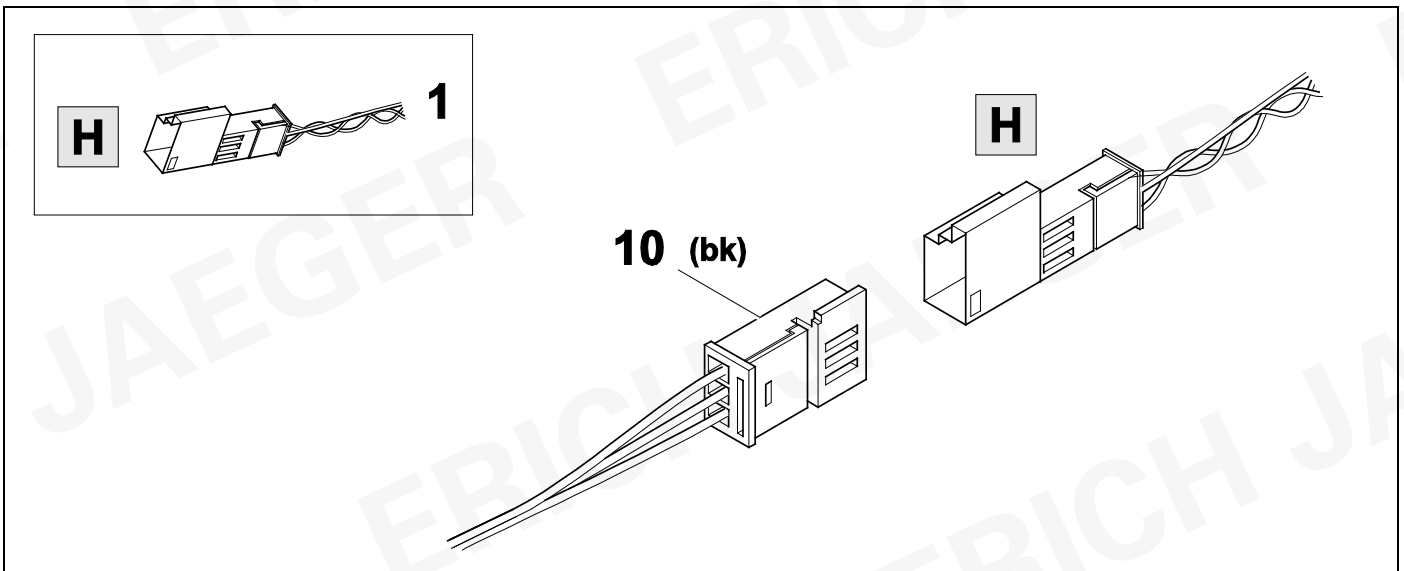



20

OPTION 1

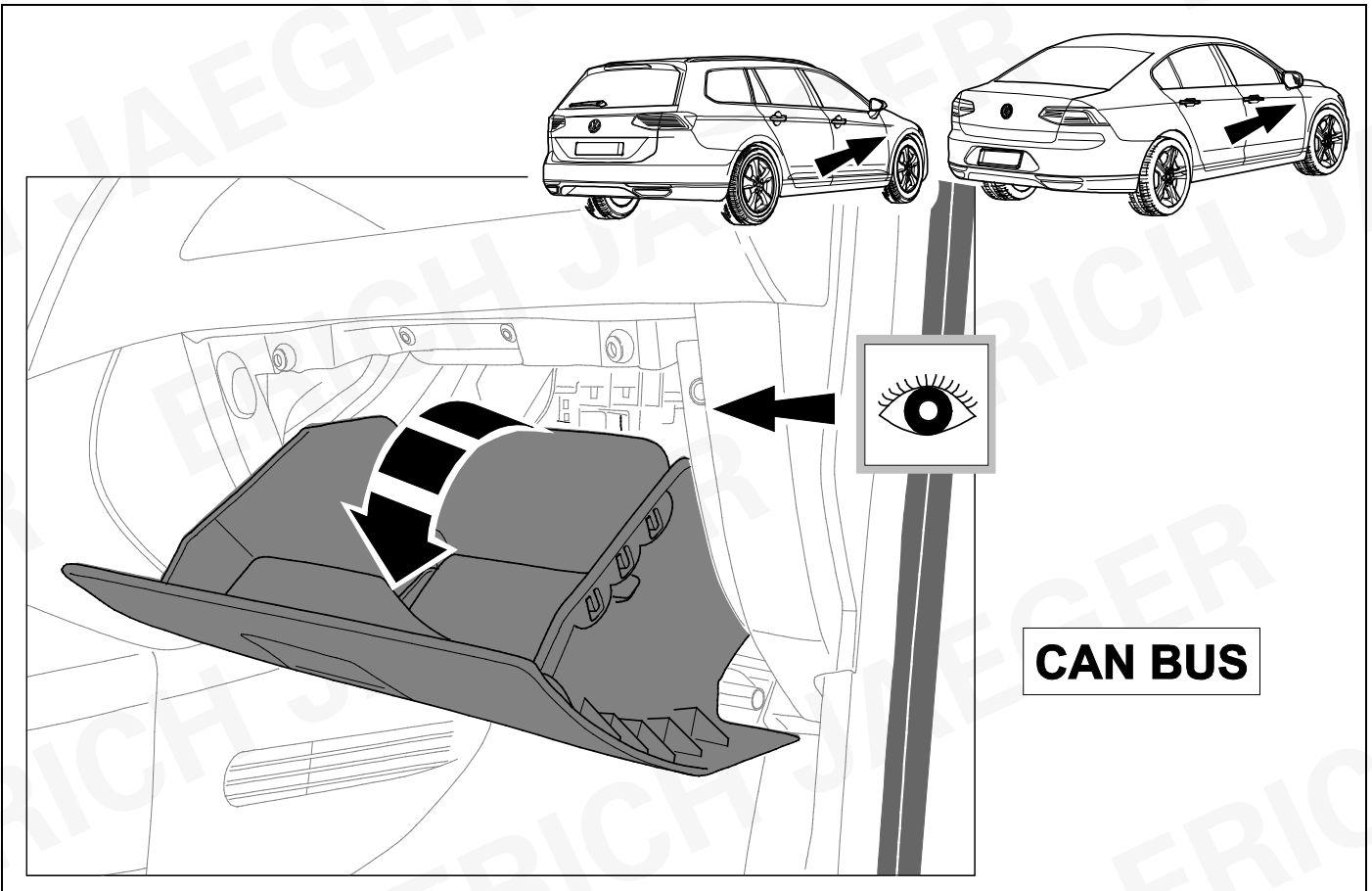

21

👁️ ➔ 11

OPTION 1

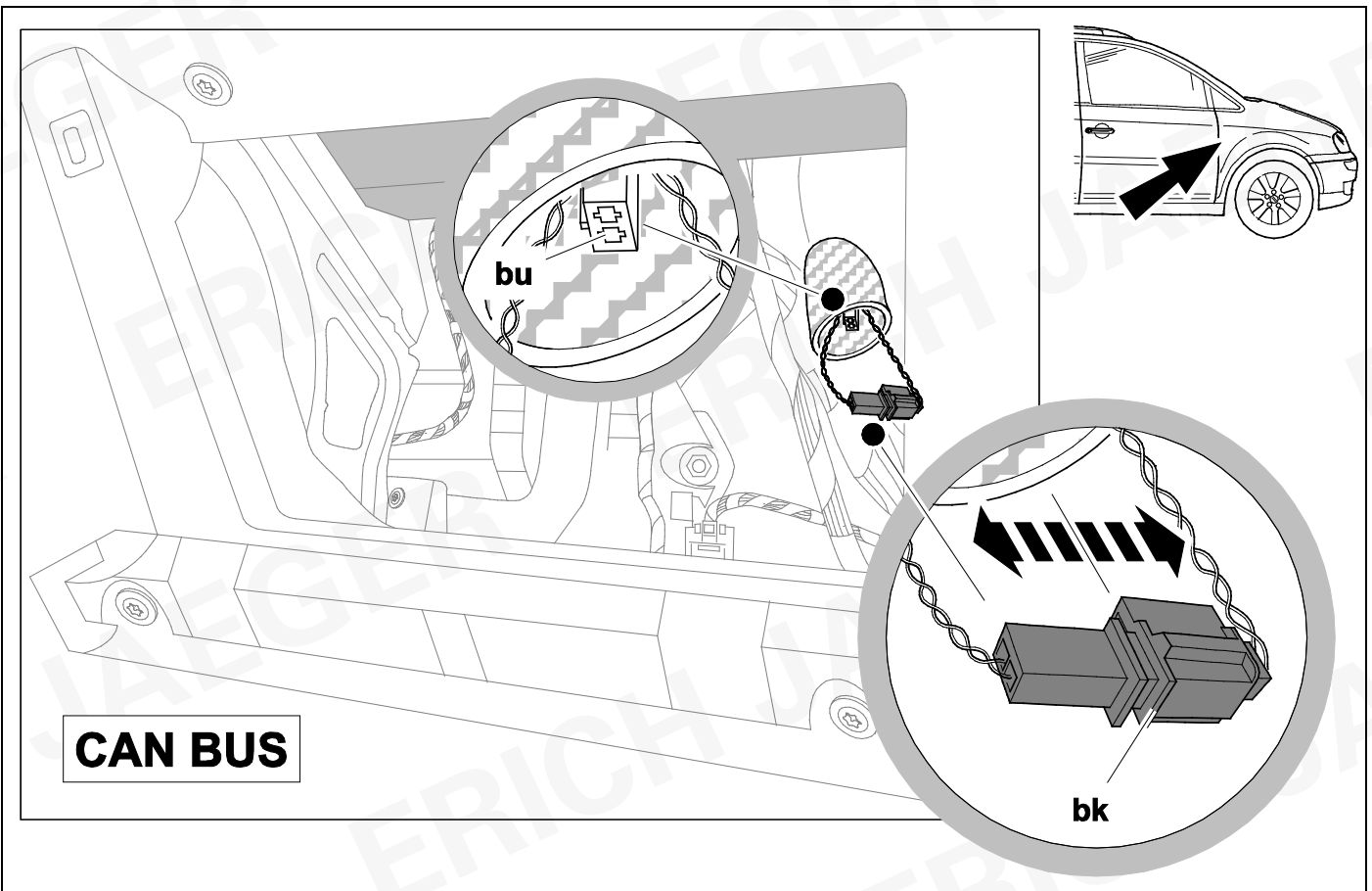

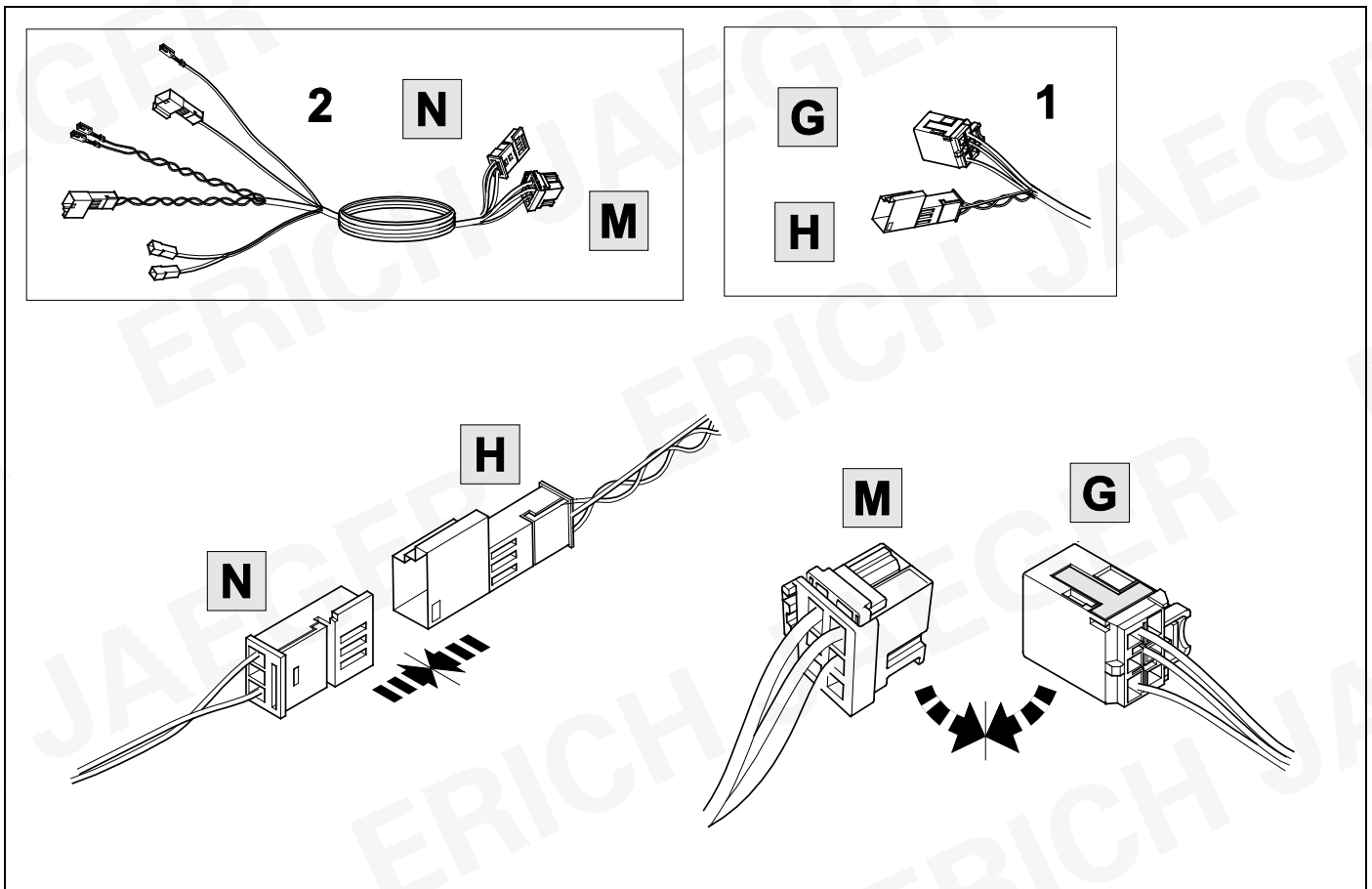
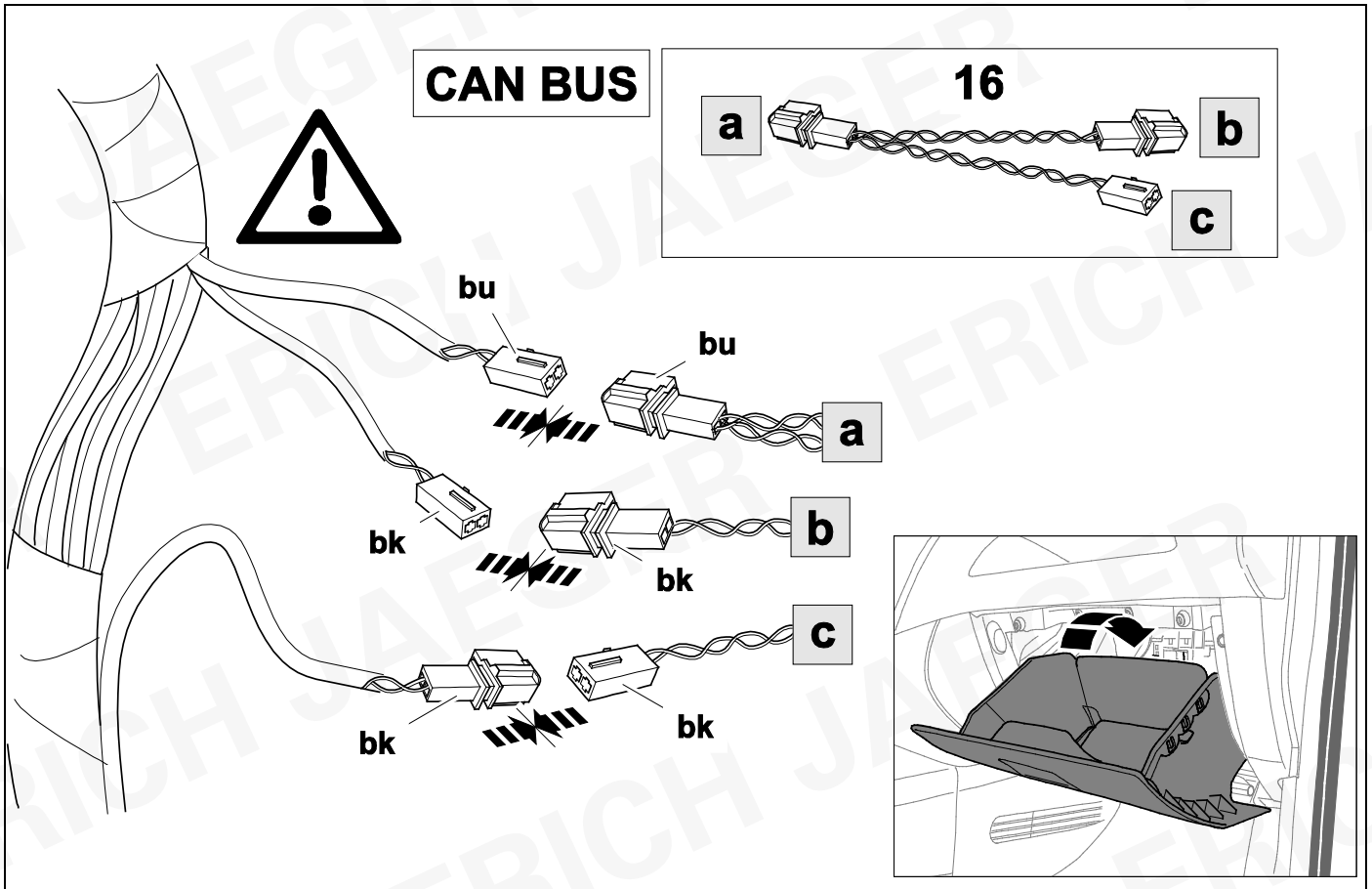

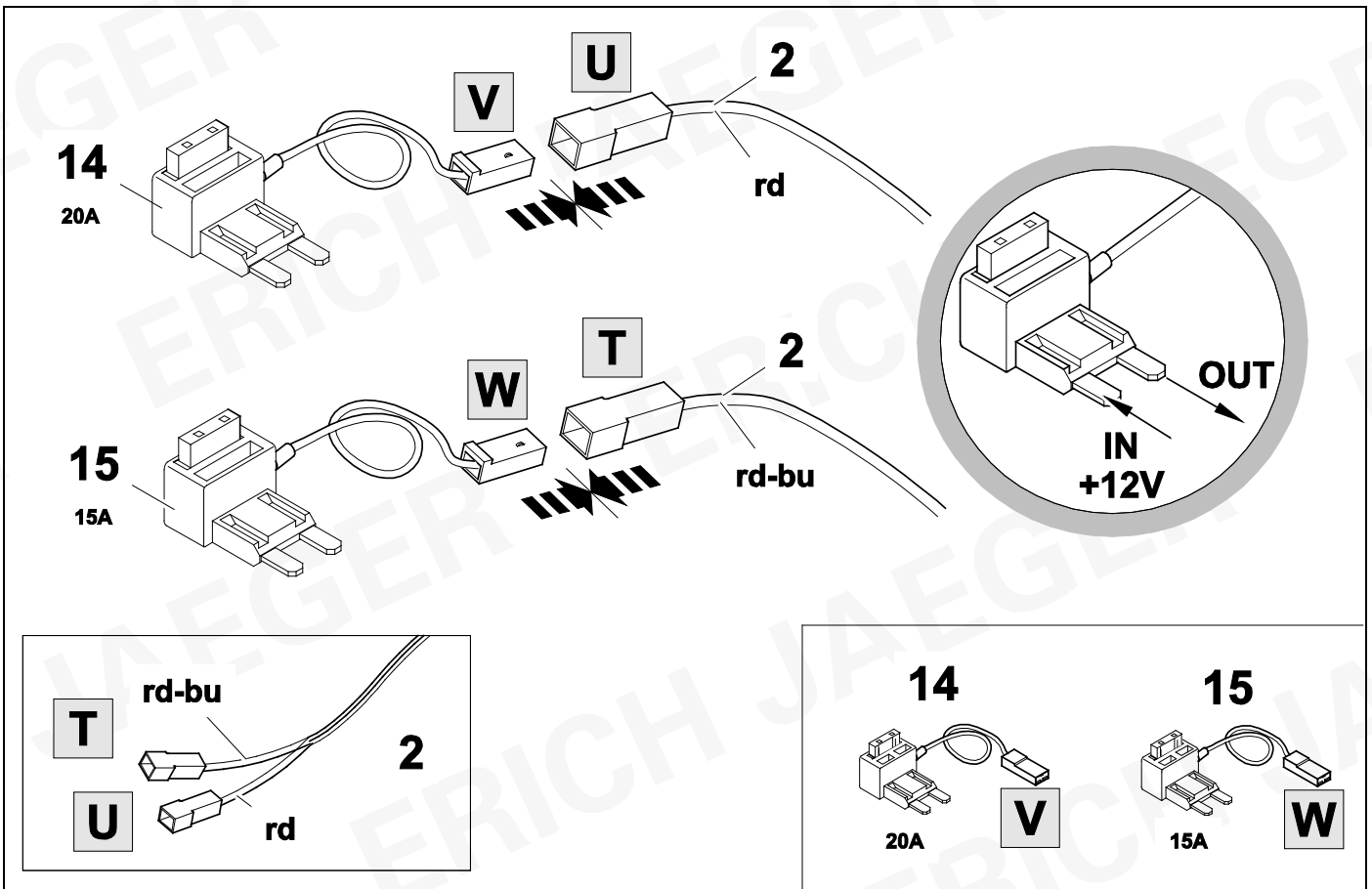
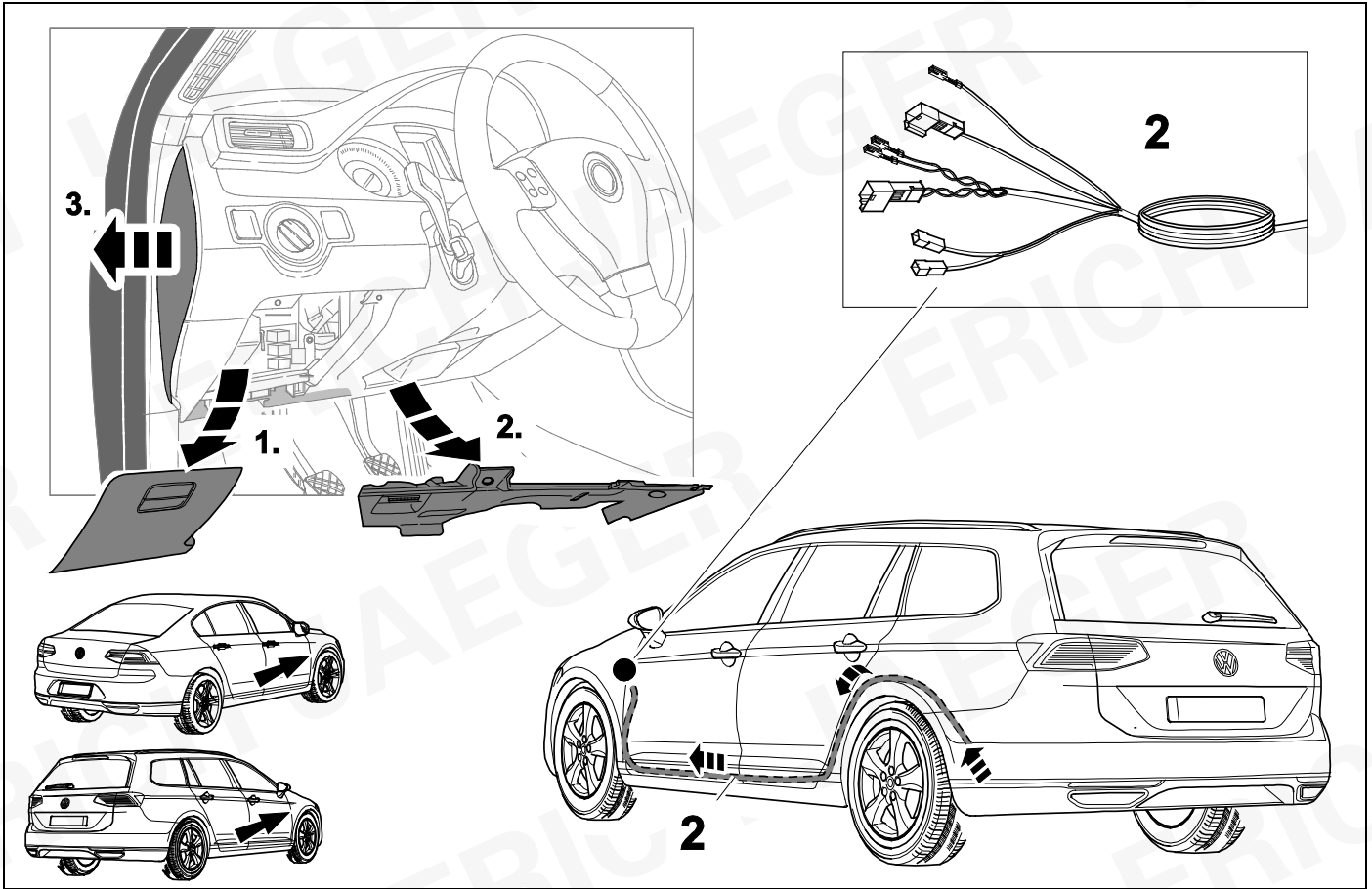

26



46

OPTION 2

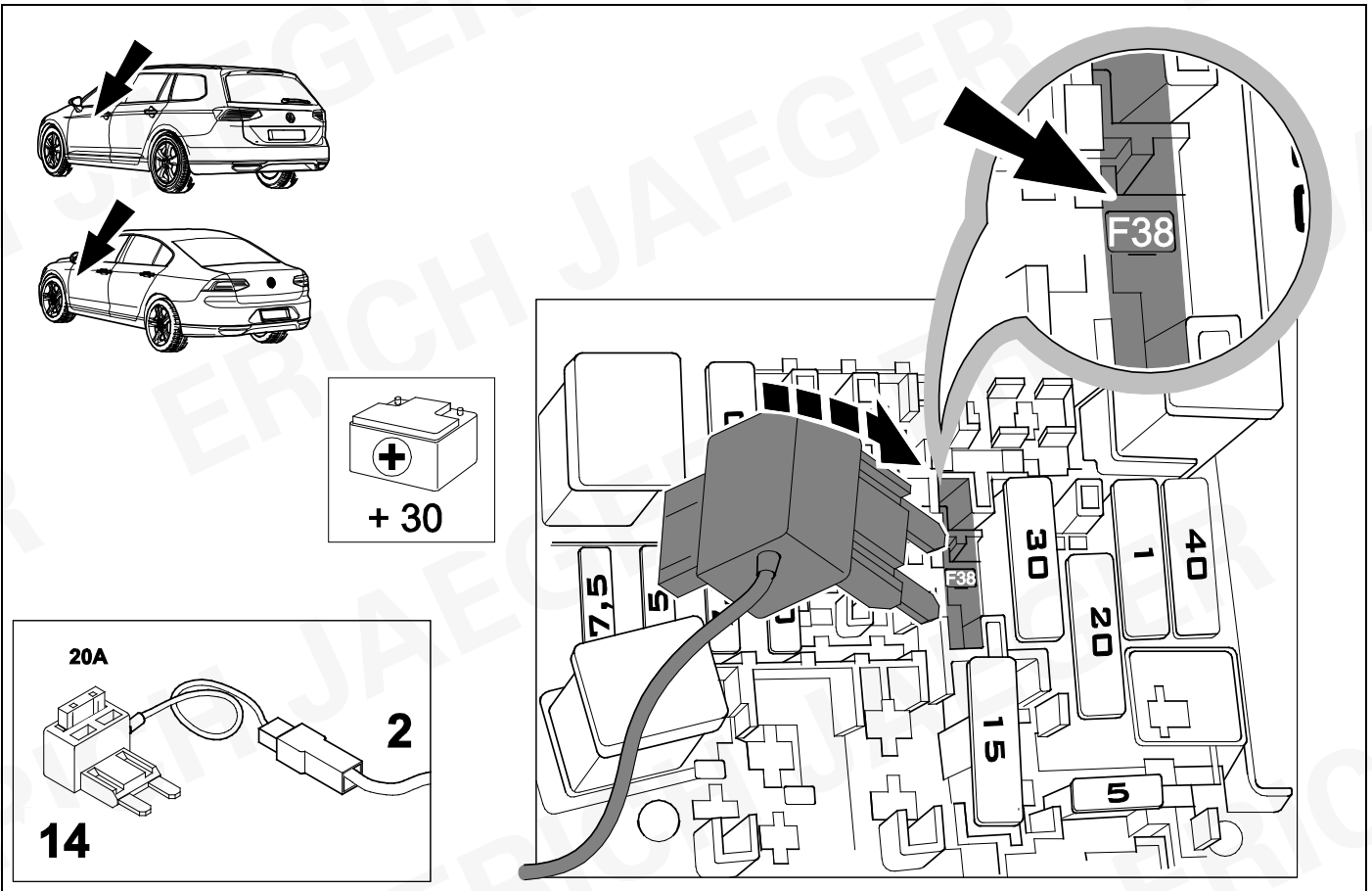

27



46

OPTION 2

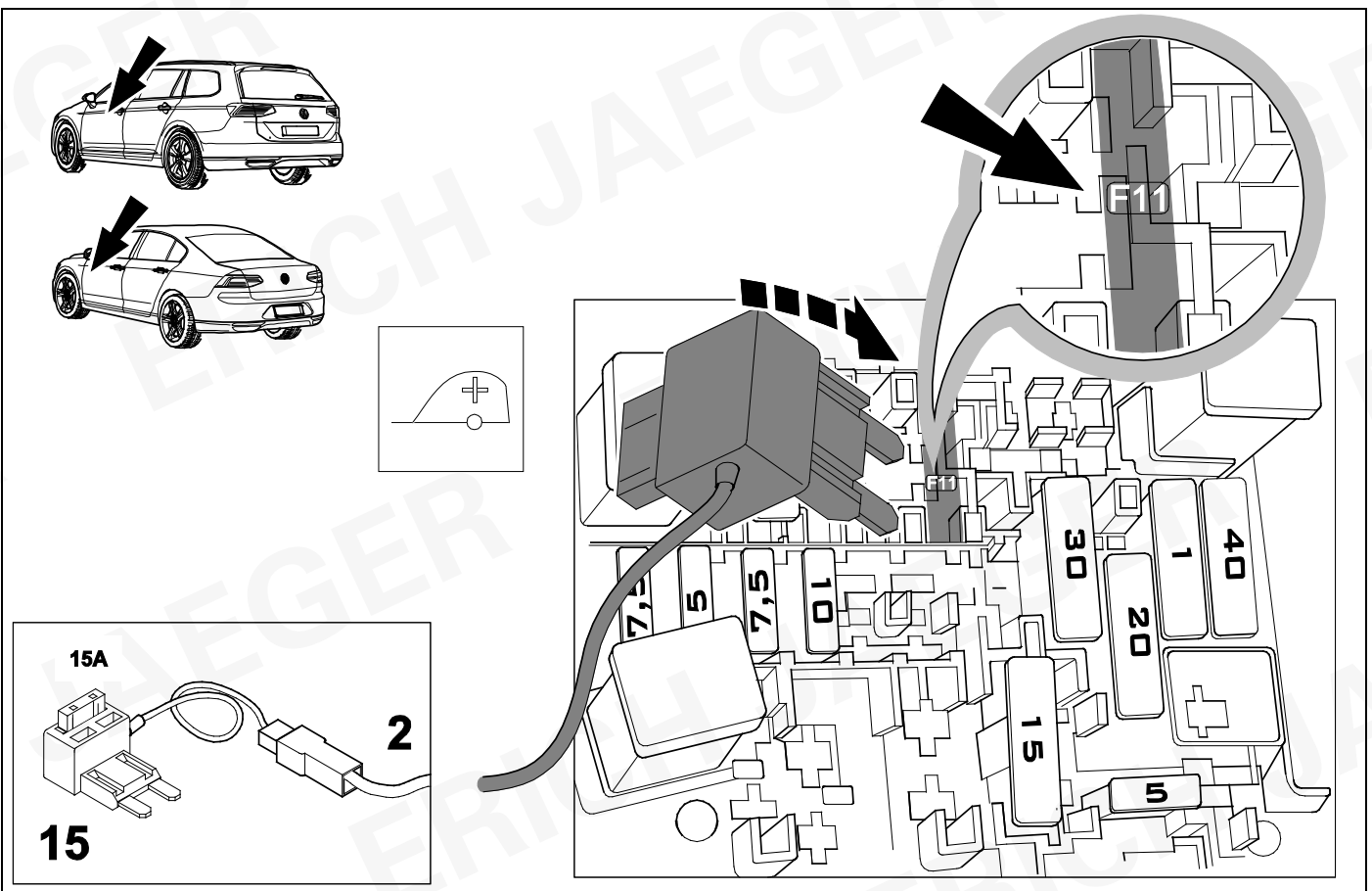

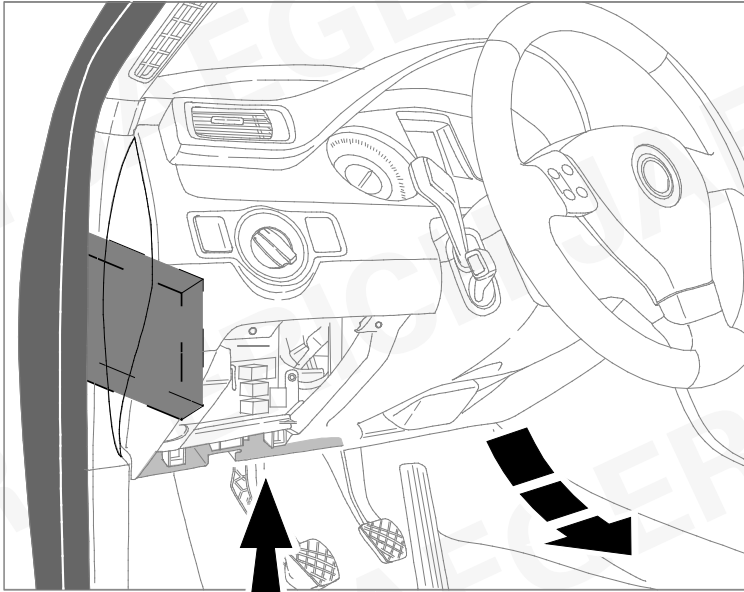

BCM

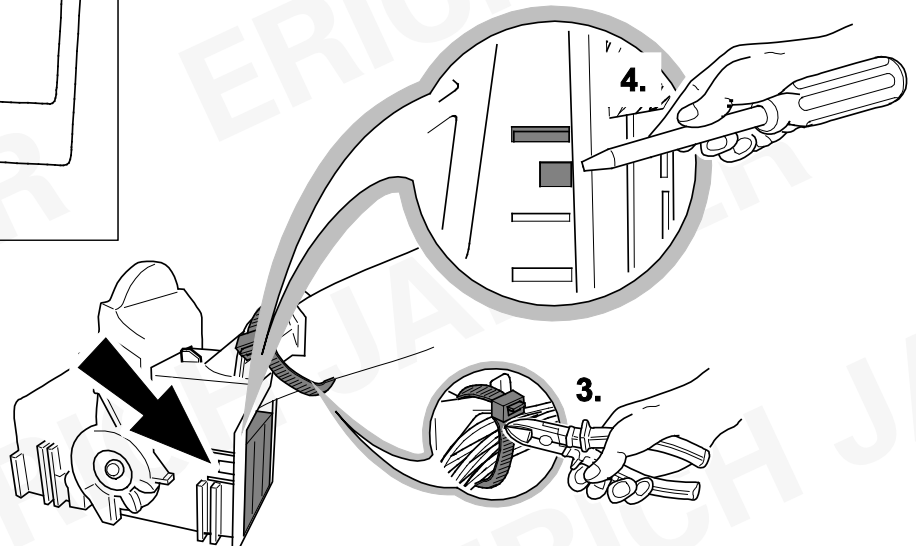
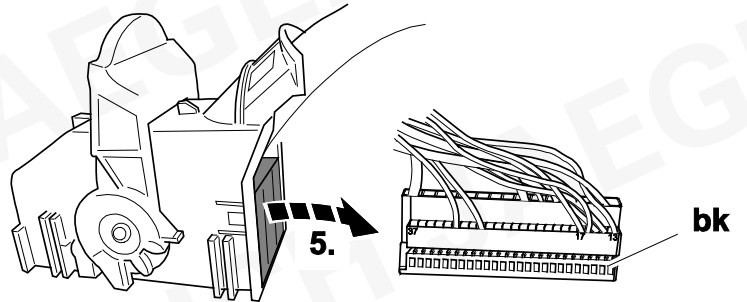
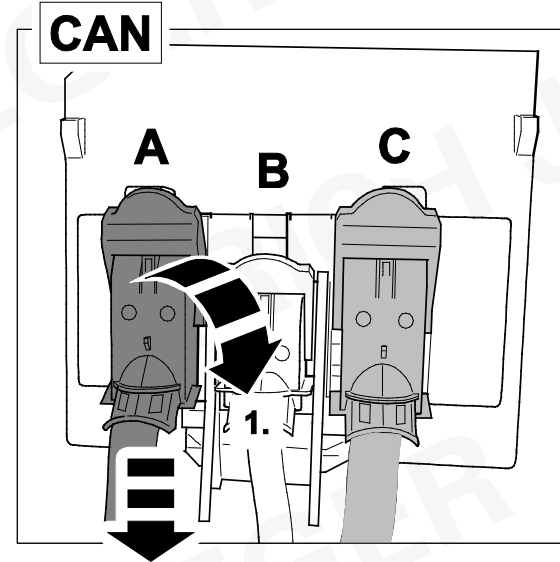
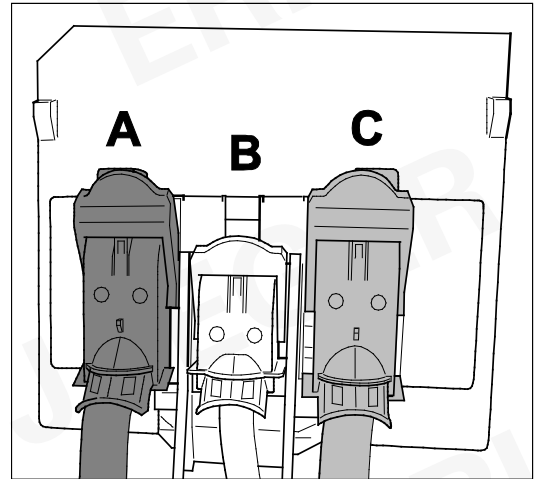
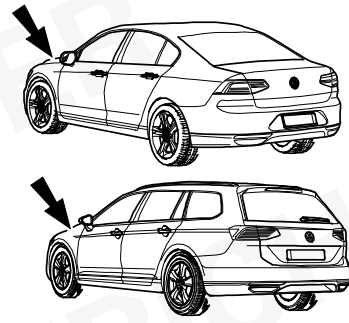
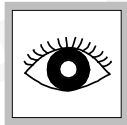

30



11

OPTION 2

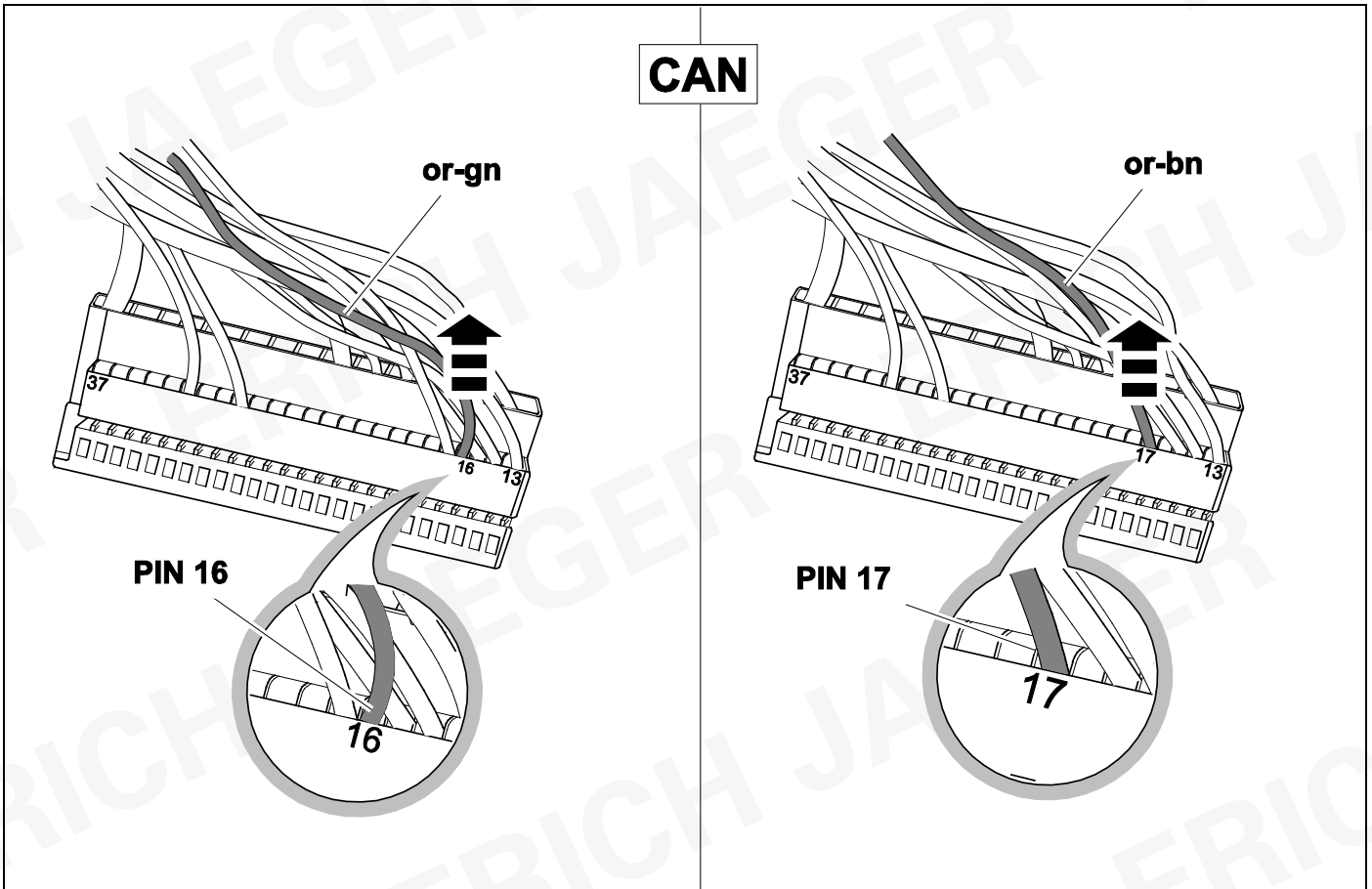

31



11

OPTION 2

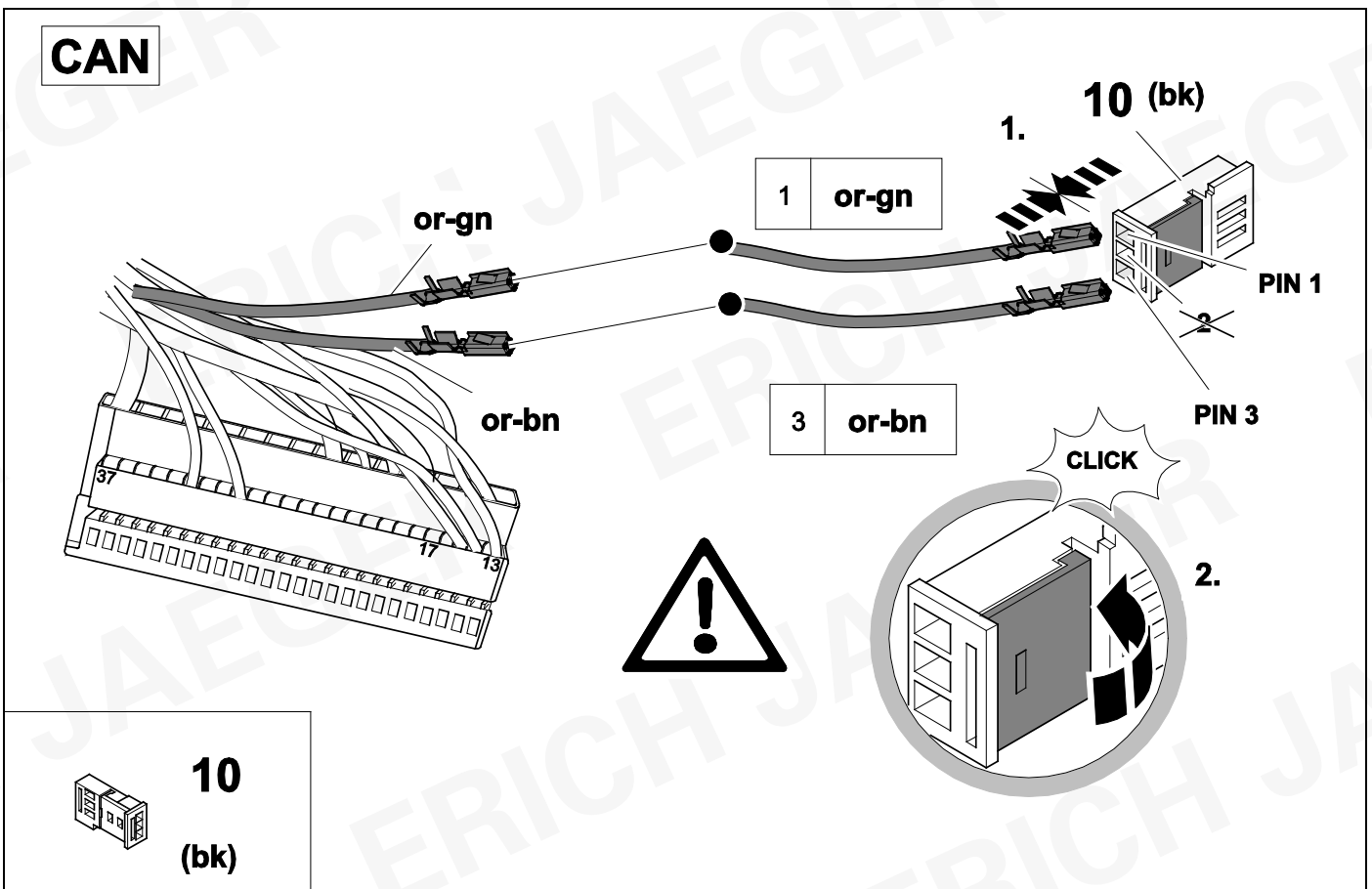

CAN

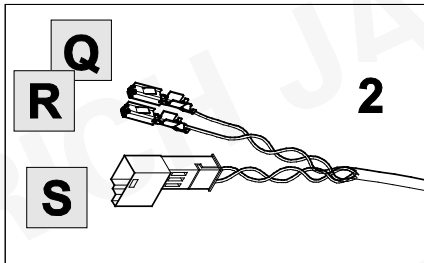
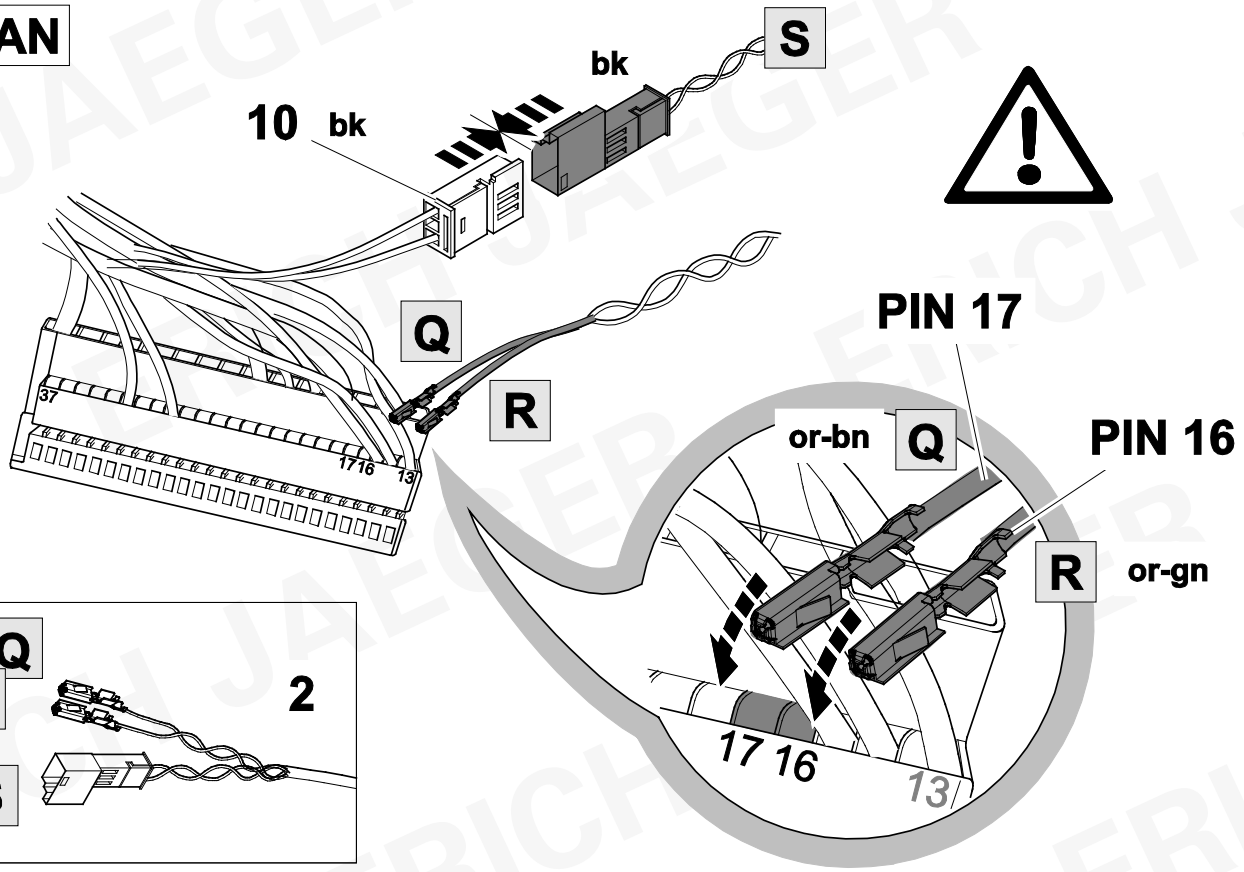

CAN

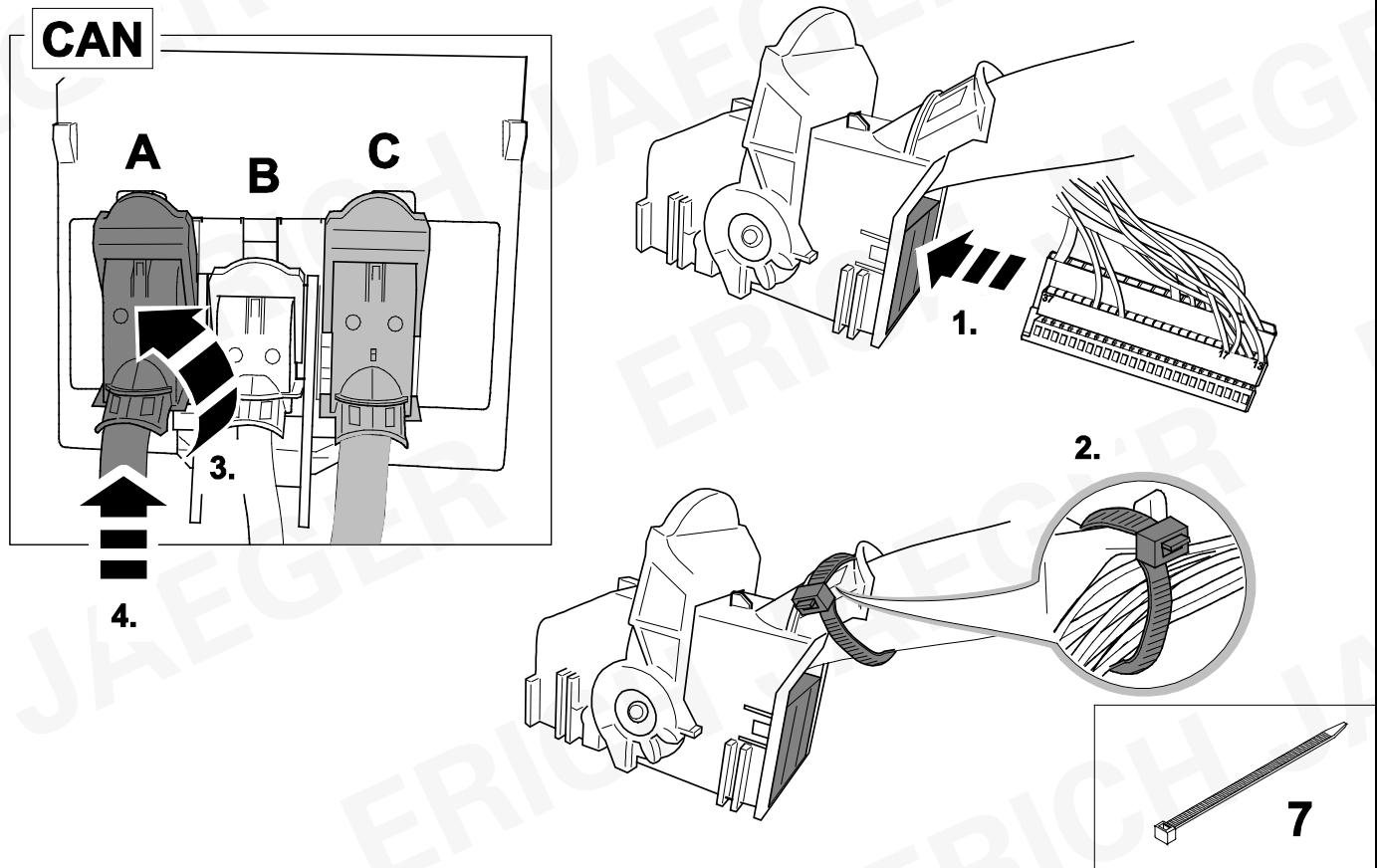

34



11

OPTION 2

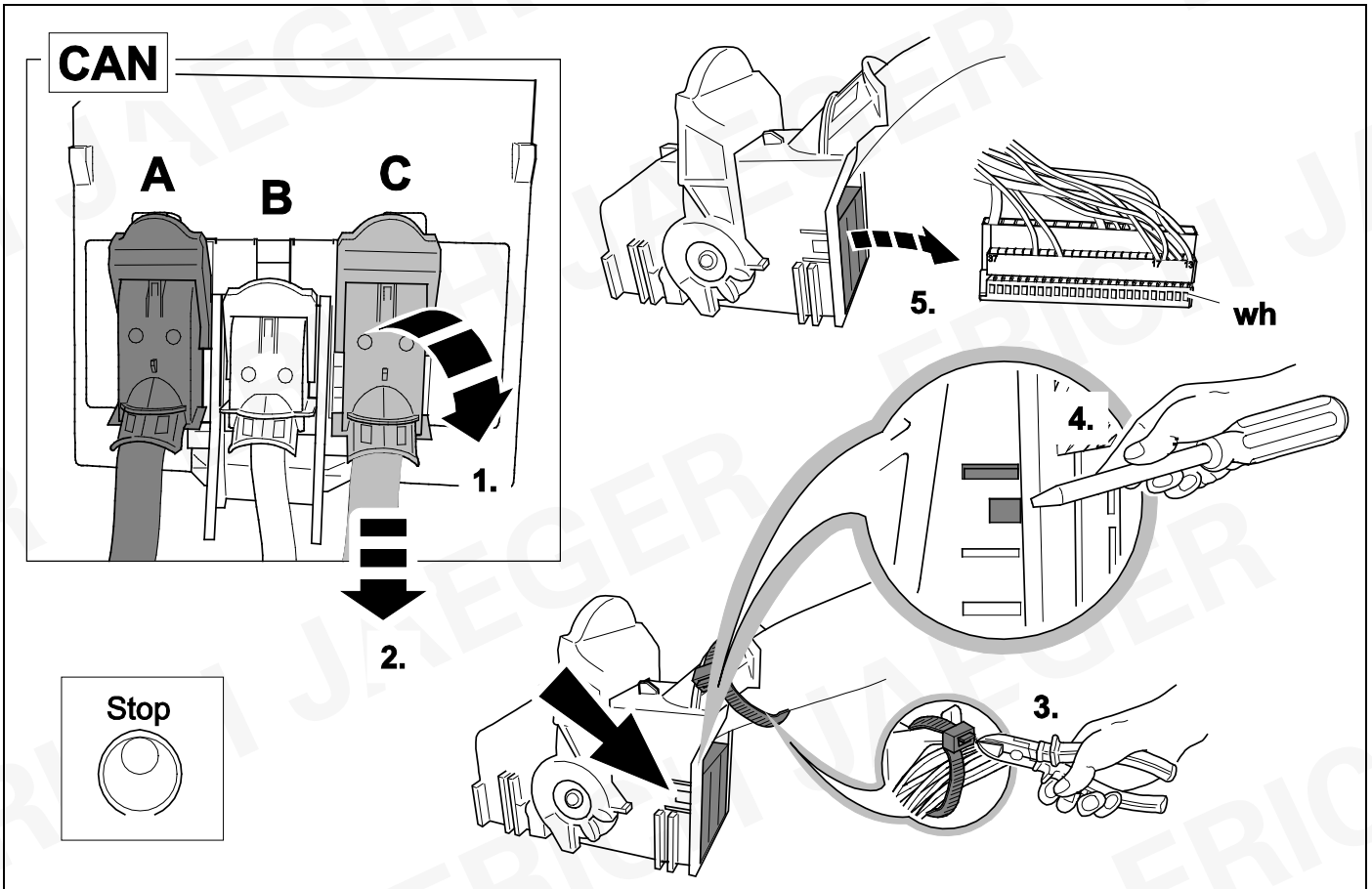

35



11

OPTION 2

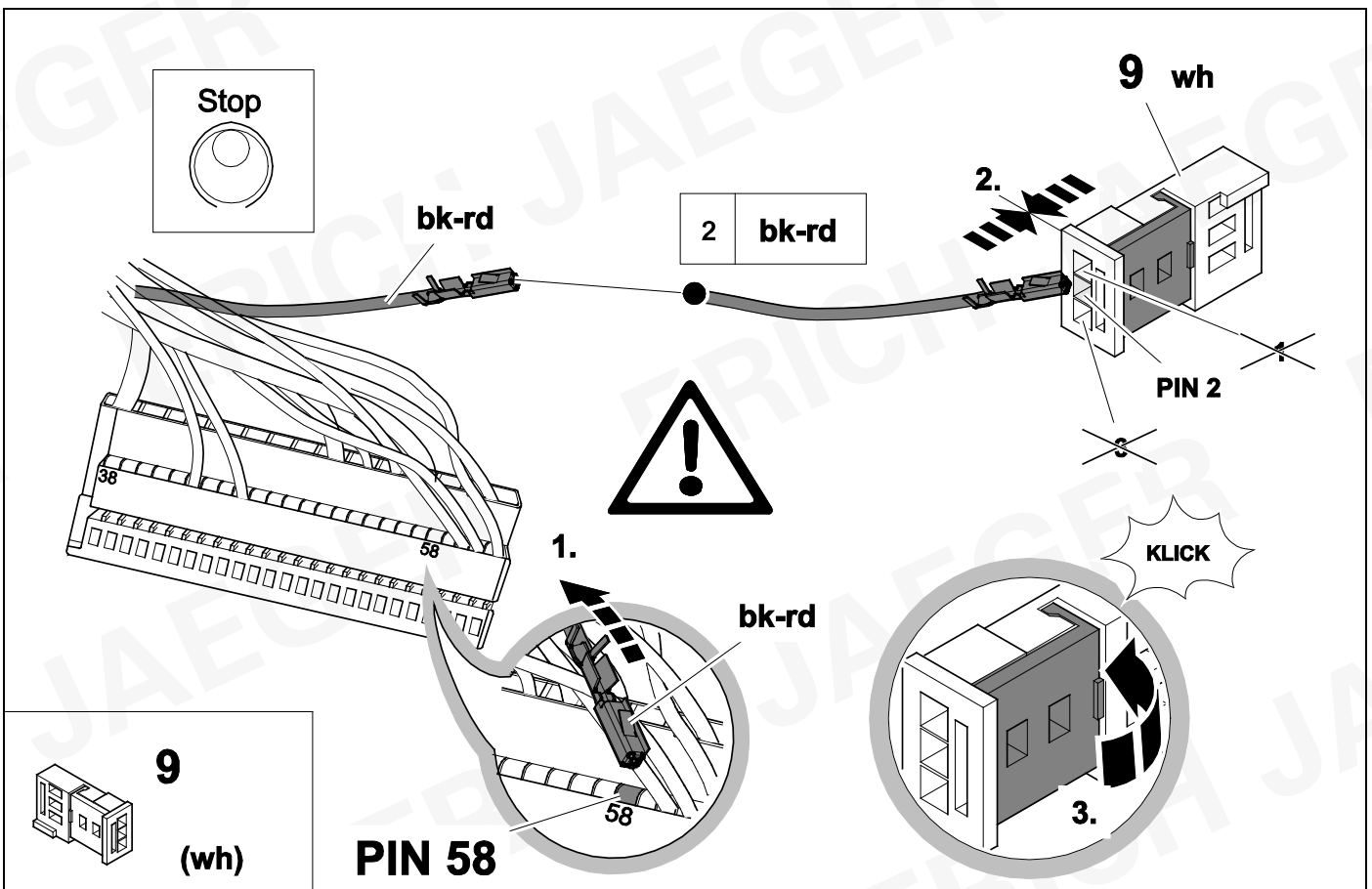



36



11

OPTION 2

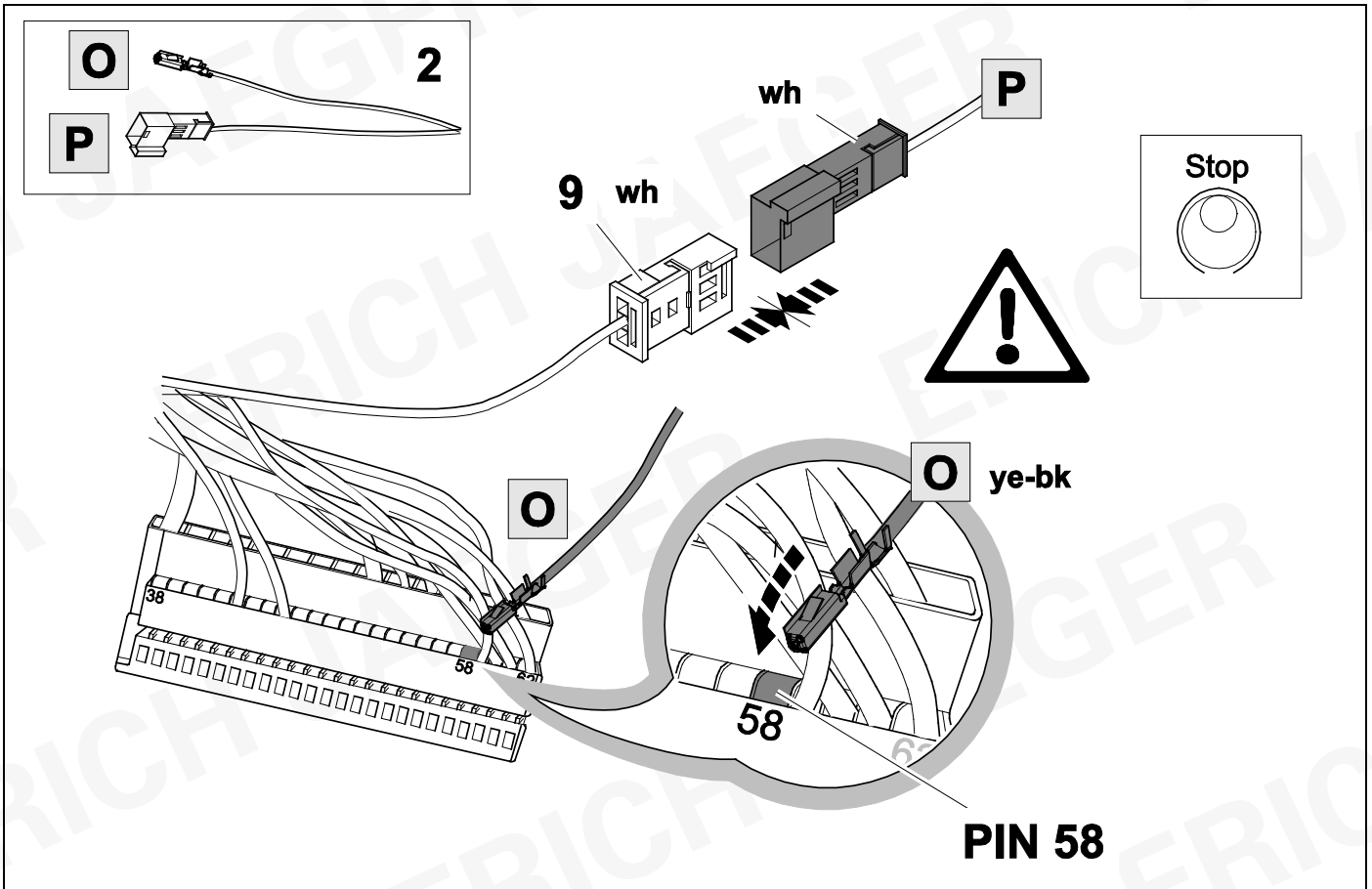

37

OPTION 2

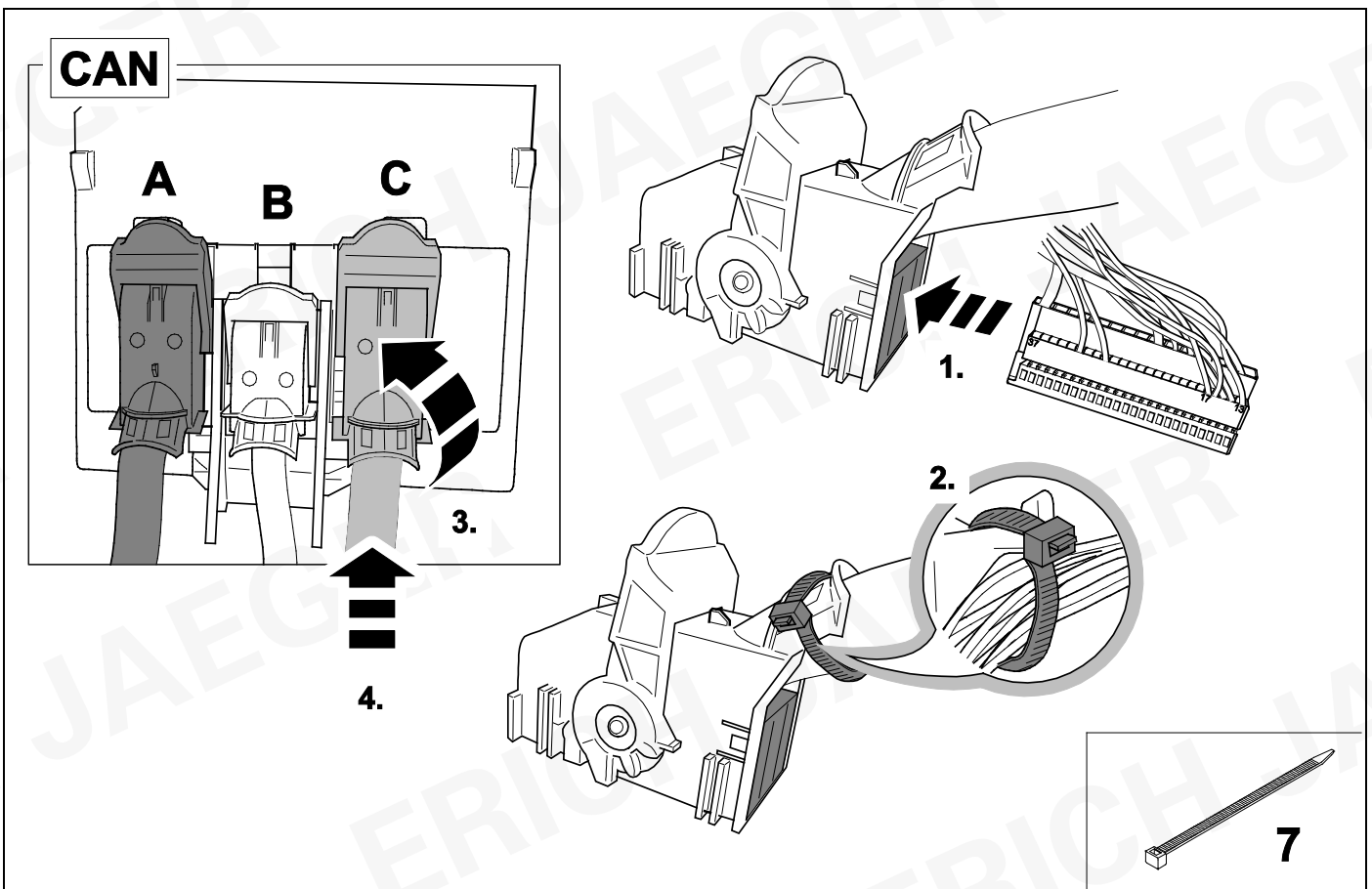

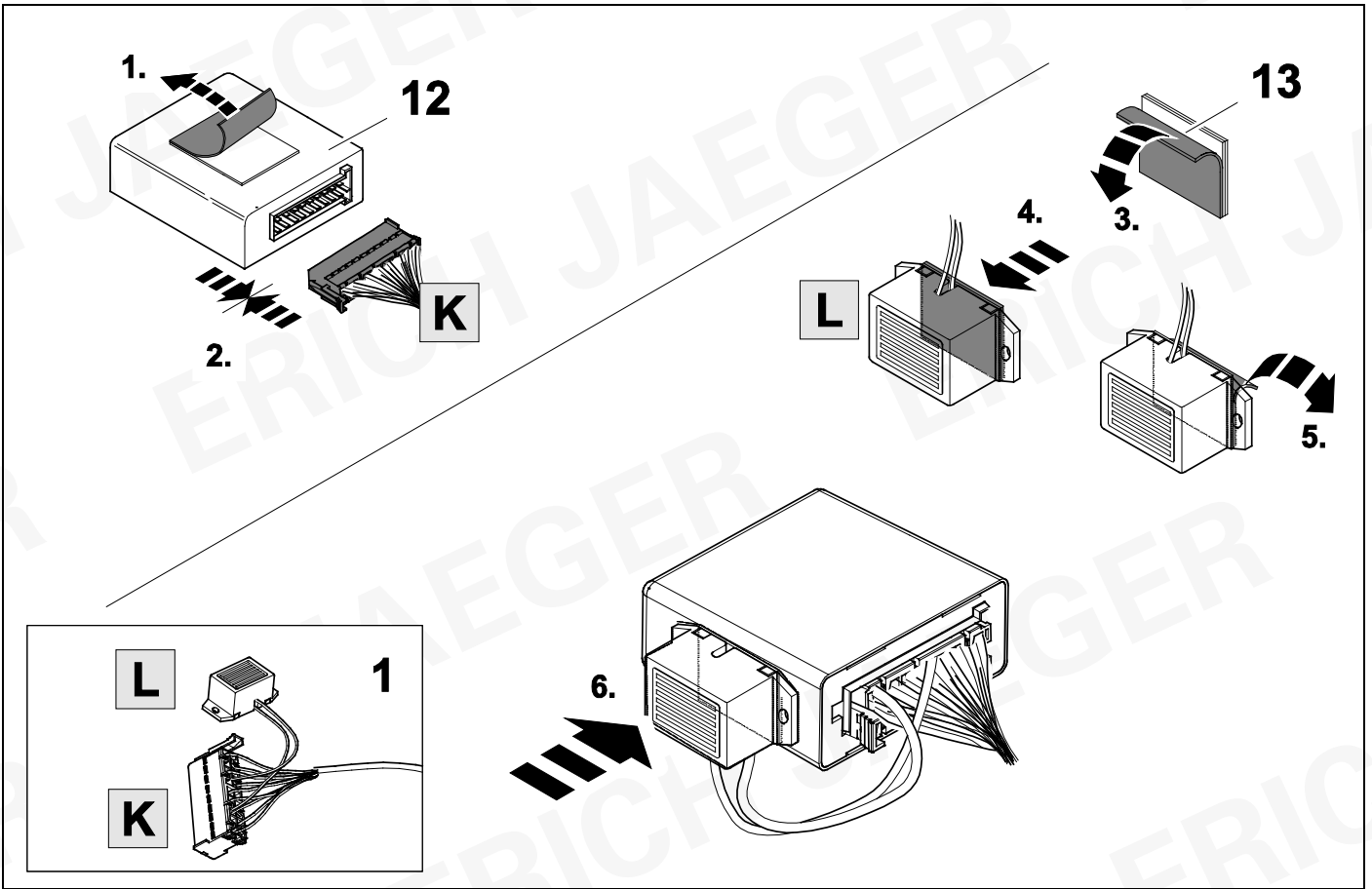

VARIANT

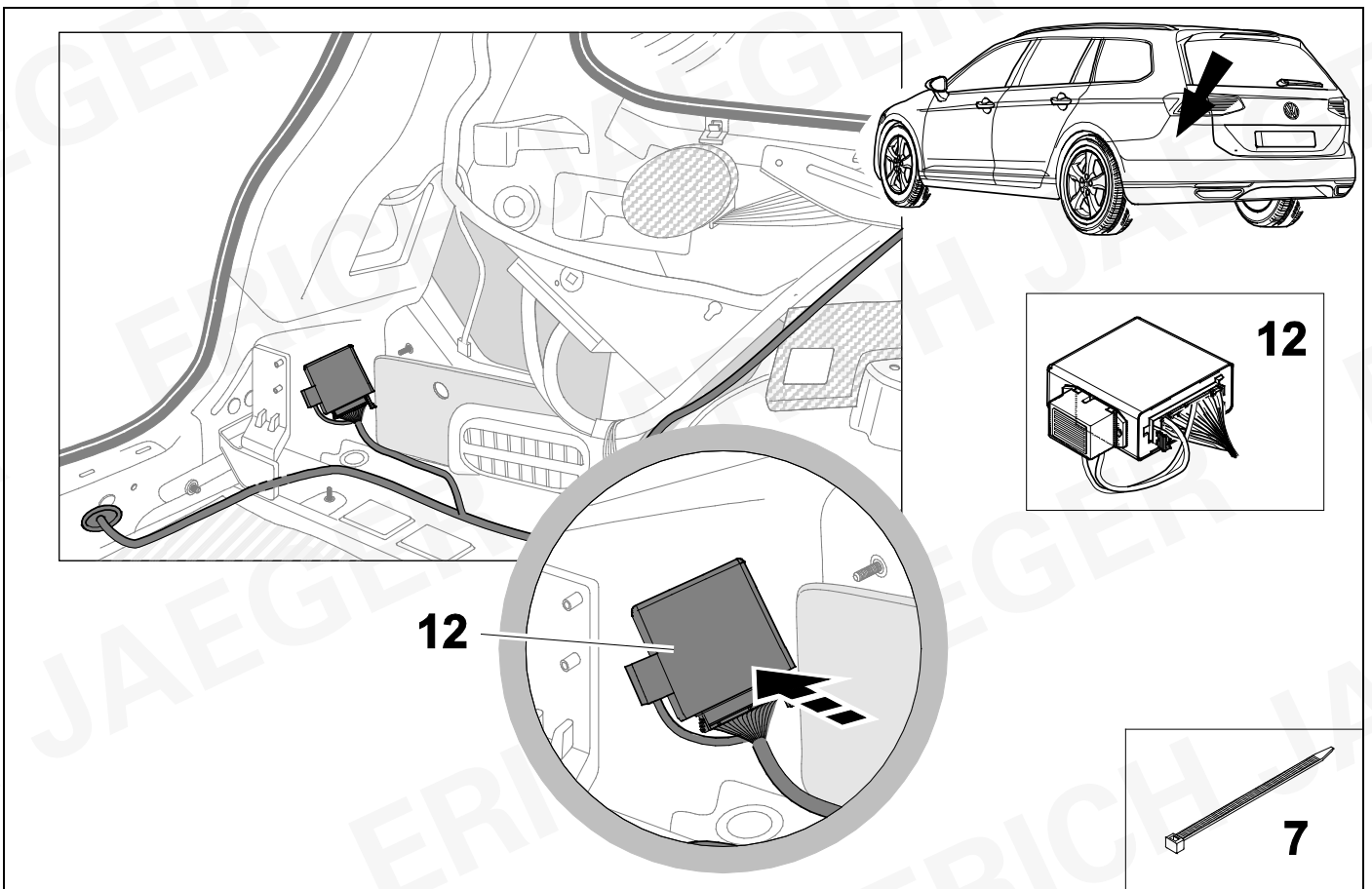

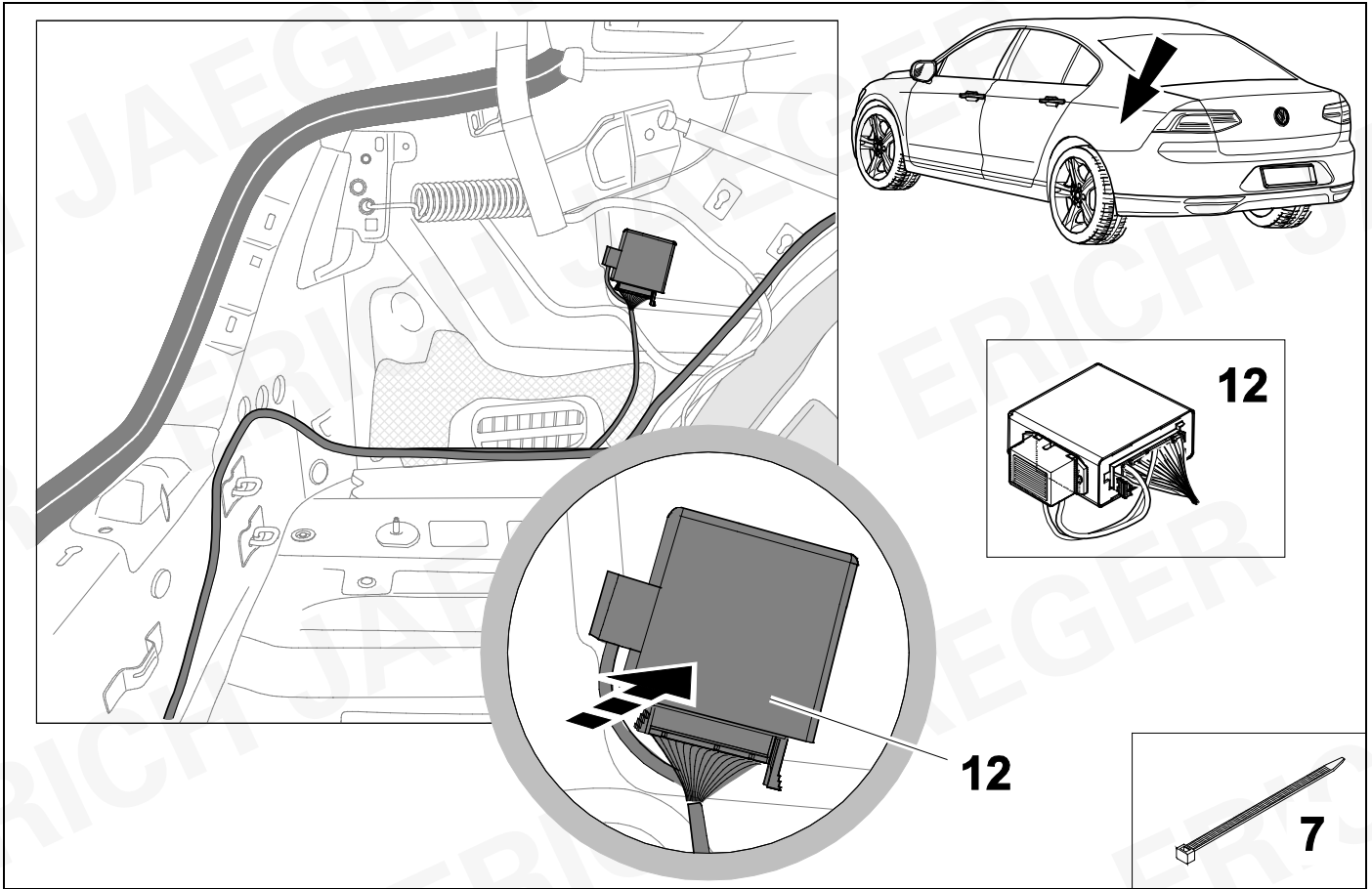

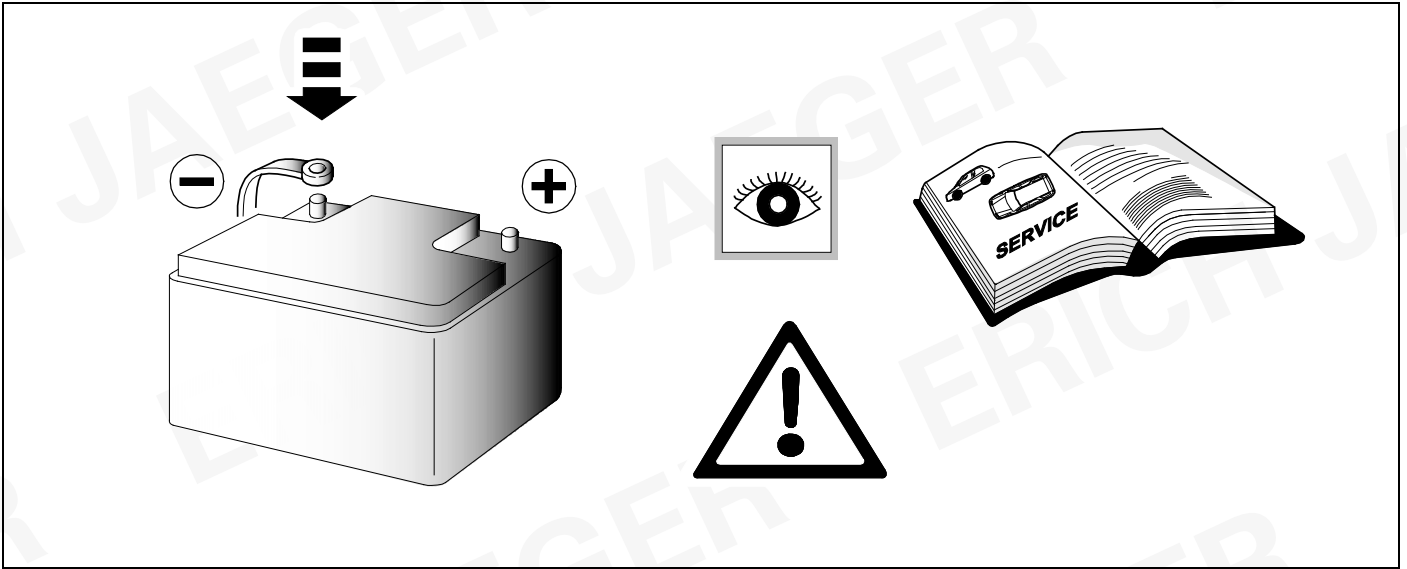

41

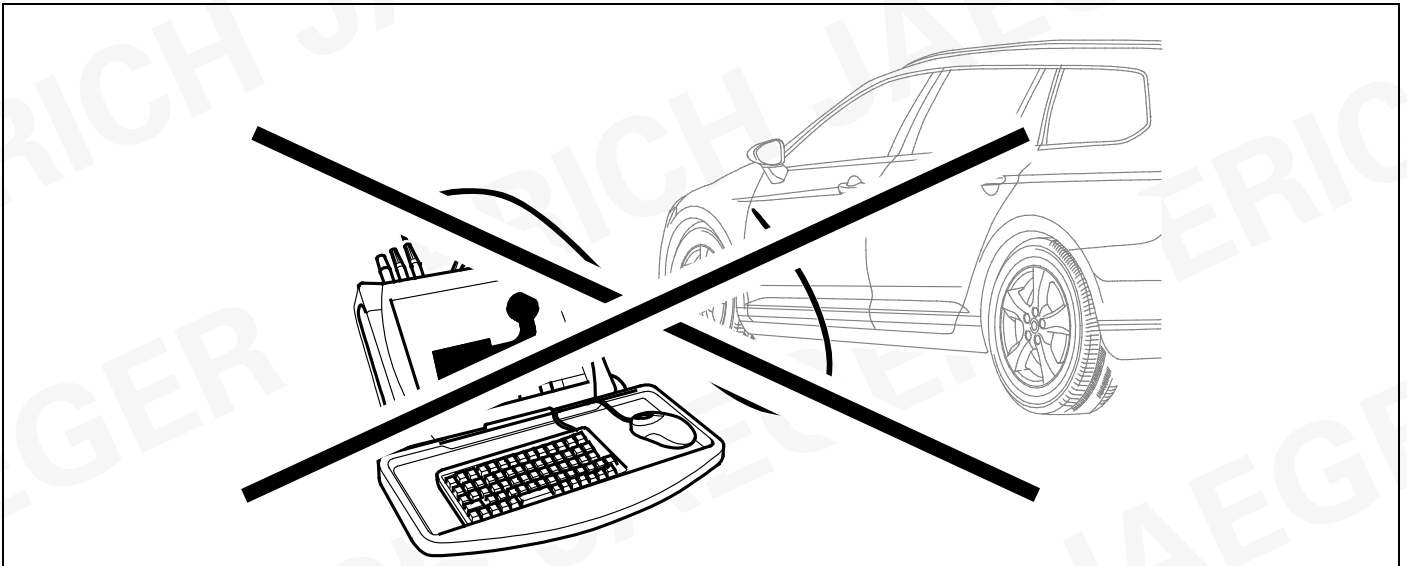

42

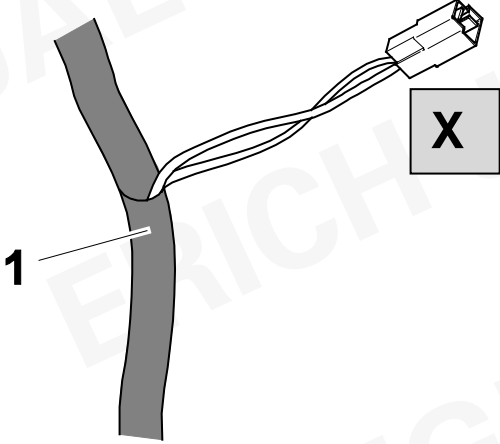
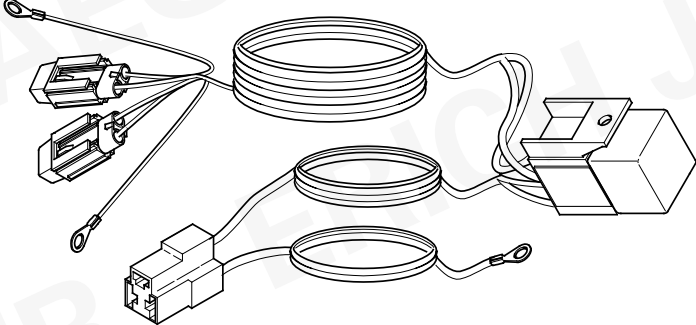

**43** OPTIONAL

		ERICH JAEGER Artikelnummer: ERICH JAEGER part number:	<b>721074</b>
			

## 44 CHECK

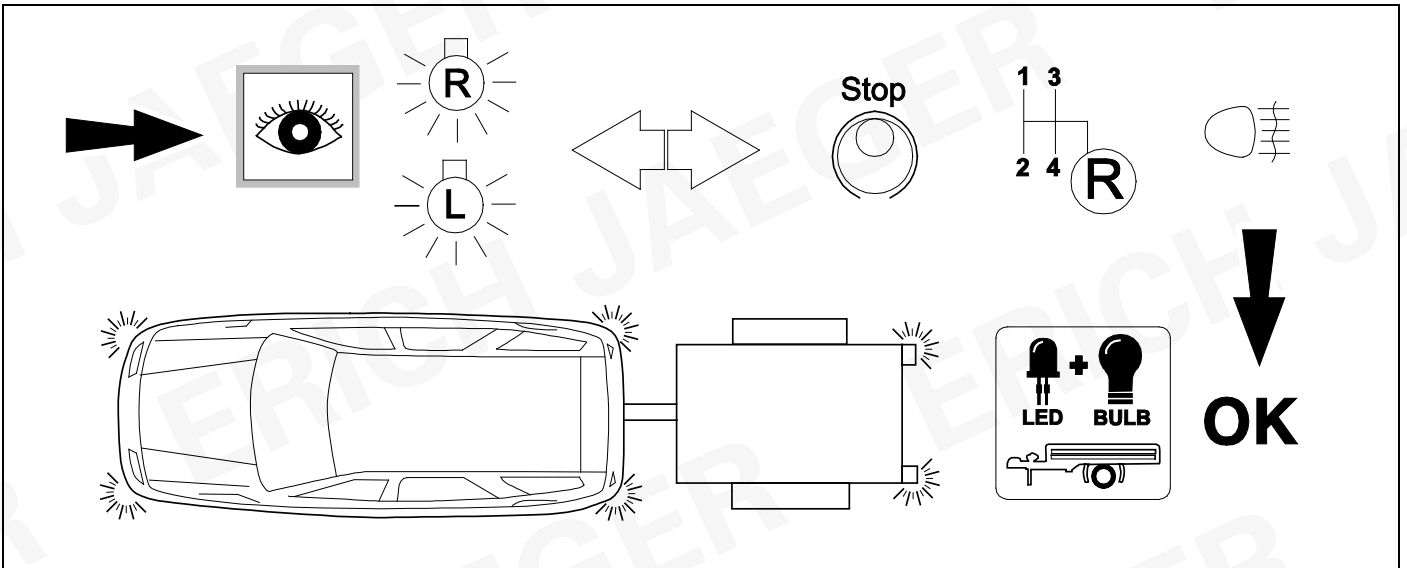

## 45 CHECK

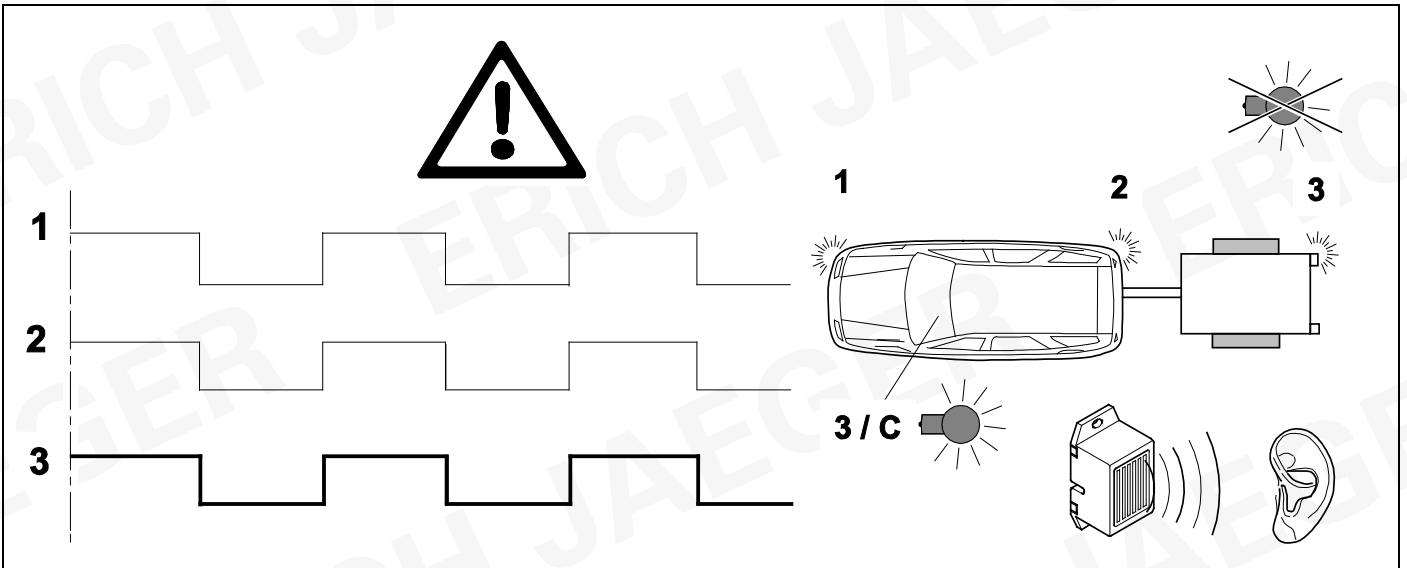

## 46 INFORMATION



26 + 27

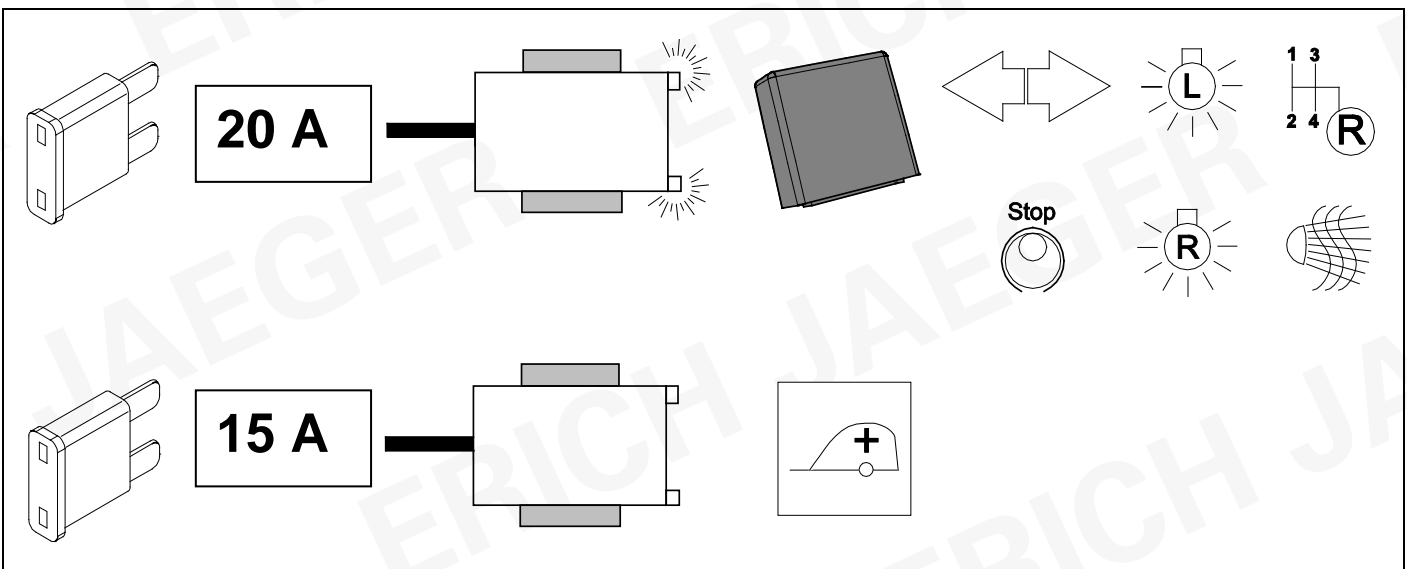

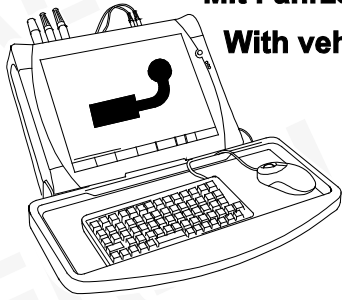

**Mit Fahrzeugkodierung**  
**With vehicle coding**

48



51



**! Achtung !**

**Diese Kodierung kann eventuell nach einem Besuch bei einer autorisierten Werkstatt verloren gehen!**

**! Attention !**

**These codings may be lost after visiting an authorized workshop!**

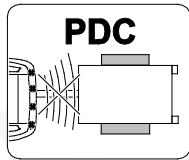
**PDC**

**TSP**  
Trailer  
Stability  
Program

**P**  
Trailer  
Assistent



48

### OPTION vehicle coding

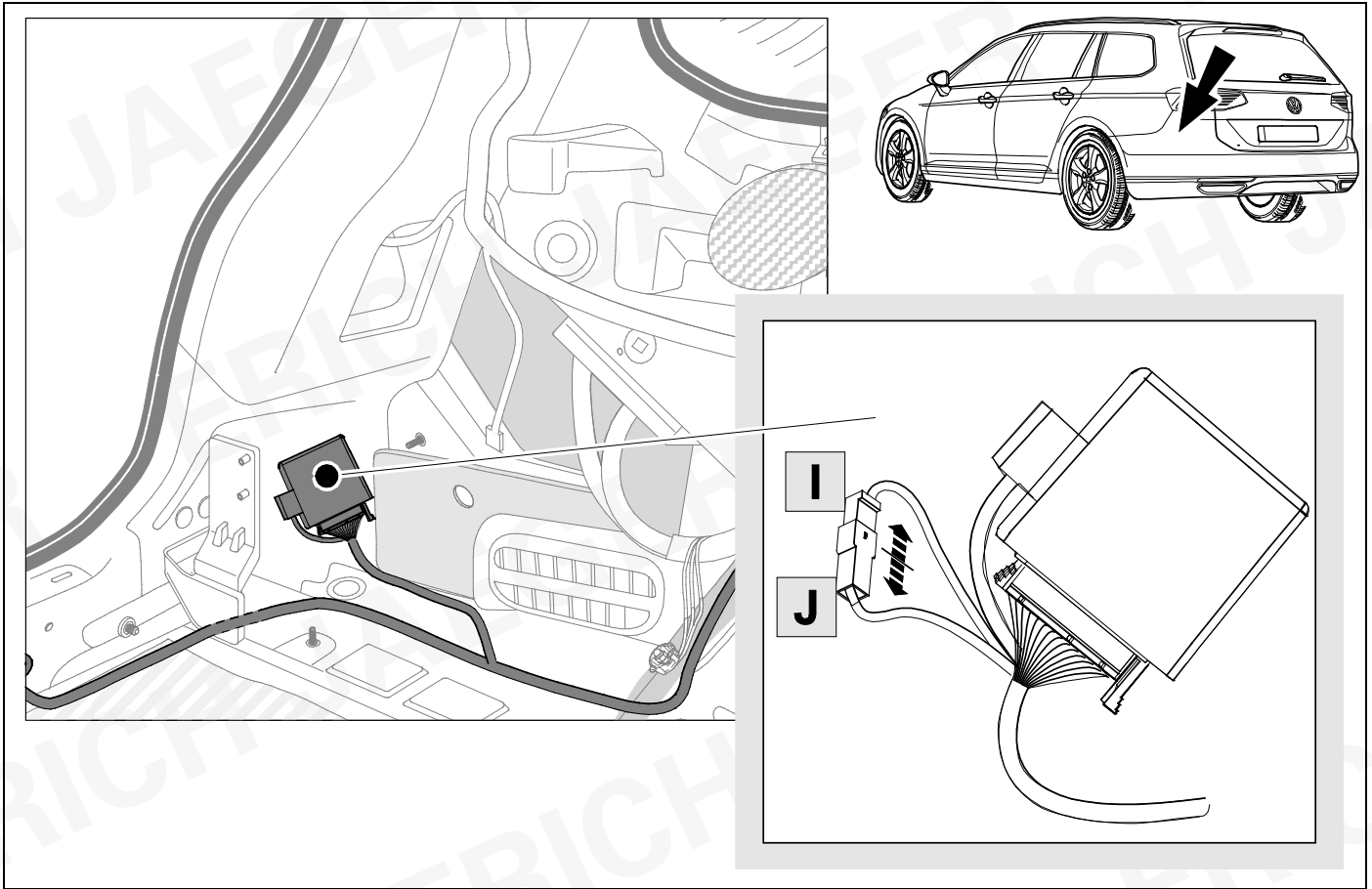

49

### OPTION vehicle coding

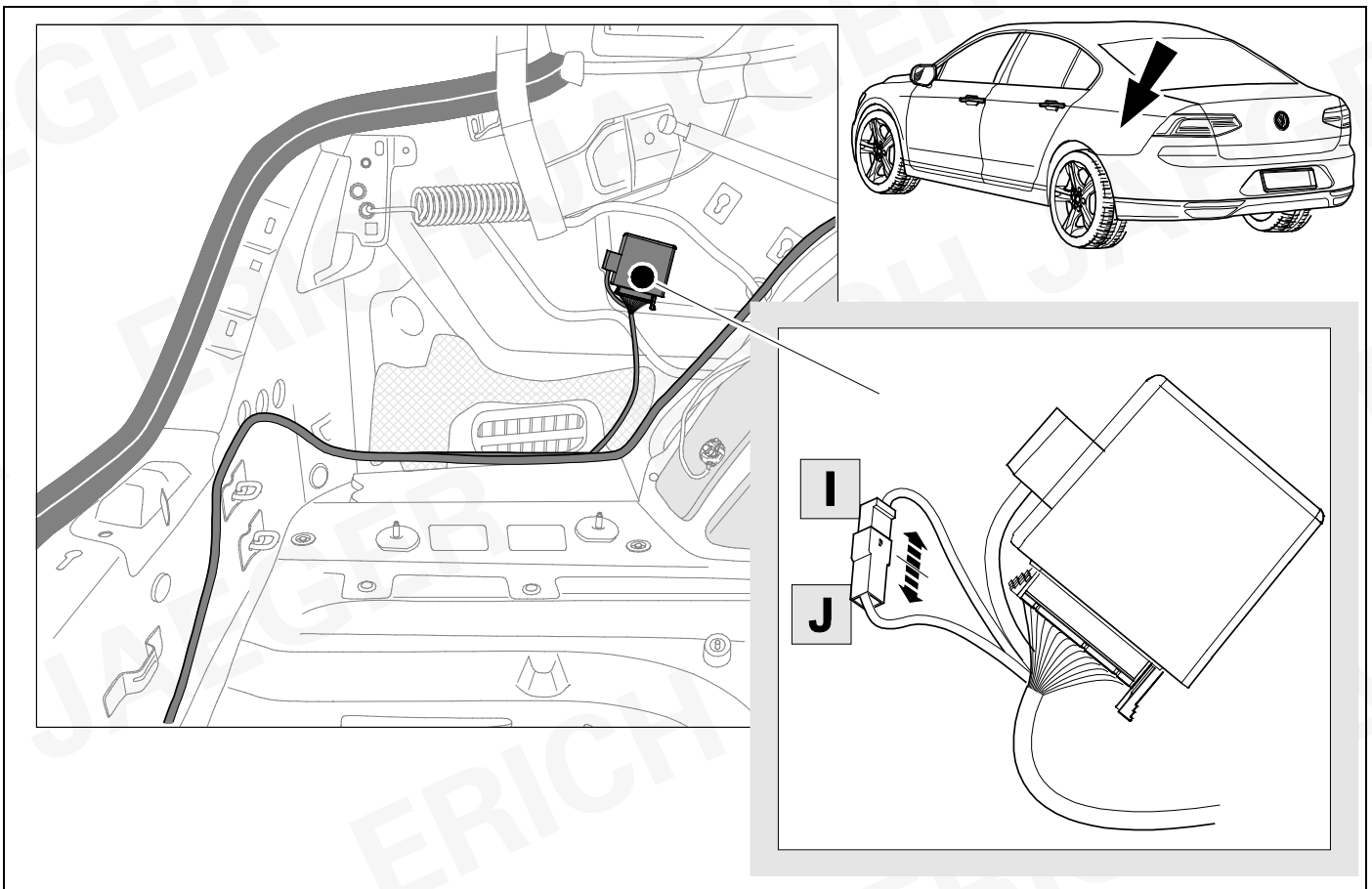

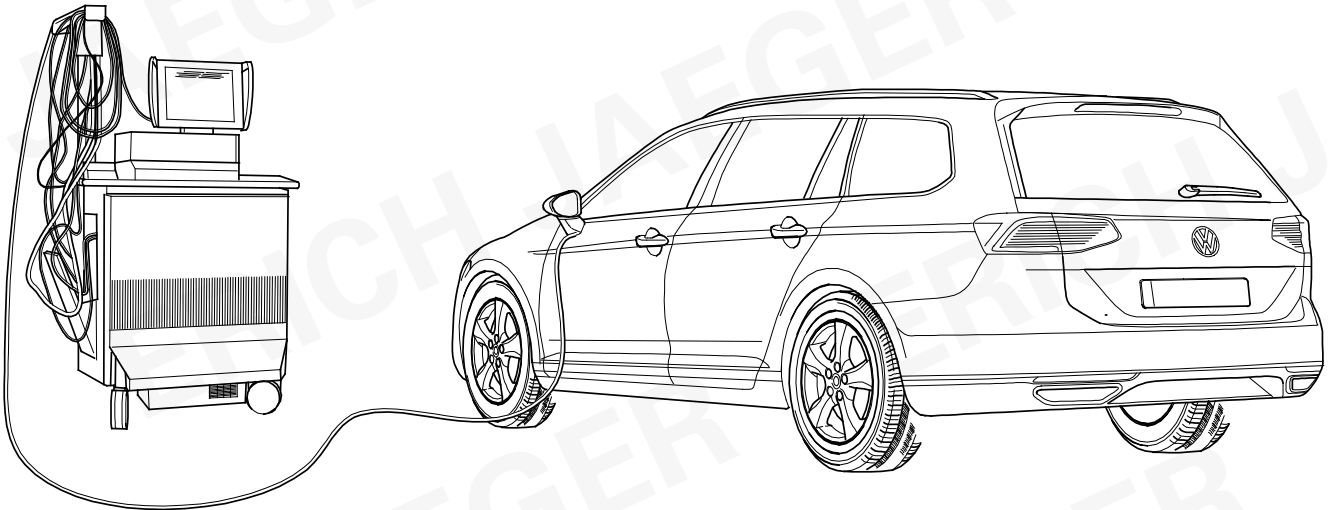

**D****Codierung bitte wie folgt durchführen:**

- Alternative Diagnosedienstleister bzw. Diagnosemethoden (lokal / offline) :
  - ODIS / VCDS
  - Hella Gutmann ( Seite 30 )
  - Autologic
  - Bosch / KTS
  - SP Diagnostic
  - SUN
  - Westfalia Auto Code
  - etc. pp.

**GB****Please effect coding as follows:**

- Alternative Diagnosis Services or diagnostic methods (local / offline) :
  - ODIS / VCDS
  - Hella Gutmann ( page 30 )
  - Autologic
  - Bosch / KTS
  - SP Diagnostic
  - SUN
  - Westfalia Auto Code
  - etc. pp.

**F****Veillez suivre le codage suivant:**

- Diagnostic services alternatives ou les méthodes de diagnostic (local/hors ligne) :
  - ODIS / VCDS
  - Hella Gutmann ( page 30 )
  - Autologic
  - Bosch / KTS
  - SP Diagnostic
  - SUN
  - Westfalia Auto Code
  - etc. pp.

**I****Favore codifica effettuate come segue:**

- -Alternativa Diagnosi Servizio o metodi diagnostici (locale/offline) :
  - ODIS / VCDS
  - Hella Gutmann ( pagina 30 )
  - Autologic
  - Bosch / KTS
  - SP Diagnostic
  - SUN
  - Westfalia Auto Code
  - etc. pp.

**E****Por favor de codificación lleva a cabo como sigue:**

- Servicio de Diagnóstico alternativa o métodos de diagnóstico (locales/fuera de linea) :
  - ODIS / VCDS
  - Hella Gutmann ( pagina 30 )
  - Autologic
  - Bosch / KTS
  - SP Diagnostic
  - SUN
  - Westfalia Auto Code
  - etc. pp.

**NL****Gelieve codering ais volgt ultgevoerd:**

- Alternatief Diagnose Dienst of diagnostische methoden (lokale/offline) :
  - ODIS / VCDS
  - Hella Gutmann ( page 30 )
  - Autologic
  - Bosch / KTS
  - SP Diagnostic
  - SUN
  - Westfalia Auto Code
  - etc. pp.

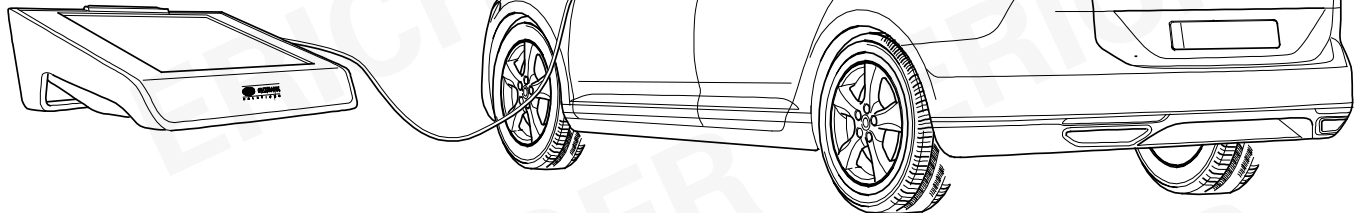

(D)	(GB)	(F)
<p><b>Die Aktivierung der Anhängerfunktionen muss wie folgt durchgeführt werden:</b></p> <ol style="list-style-type: none"> <li>1. Fahrzeugauswahl</li> <li>2. Zu Diagnose – Codierung wechseln</li> <li>3. Anhängerkupplung de-/aktivieren</li> <li>4. Diagnose Interface Bus auswählen</li> <li>5. Anleitung folgen</li> </ol> <p><b>Fahrzeuge mit Assistenzsystemen</b></p> <ol style="list-style-type: none"> <li>6. AHK an Assistenzsysteme anpassen ausführen</li> <li>7. Anleitung folgen</li> <li>8. Diagnose</li> <li>9. Fehlerspeicher auslesen, ggf. löschen</li> <li>10. Fertig</li> </ol>	<p><b>The activation of the trailer functions must be performed:</b></p> <ol style="list-style-type: none"> <li>1. Vehicle selection</li> <li>2. switch to diagnostics - coding</li> <li>3. Deactive/aktive trailer coupling</li> <li>4. Select diagnostic interface Bus</li> <li>5. Follow instructions</li> </ol> <p><b>Vehicle with assistance systems</b></p> <ol style="list-style-type: none"> <li>6. perform adaptation of trailer coupling on assistance systems</li> <li>7. Follow instructions</li> <li>8. Diagnostics</li> <li>9. Read out error memory, delete if necessary</li> <li>10. Done</li> </ol>	<p><b>Pour activer l'attelage, procéder de la façon suivante:</b></p> <ol style="list-style-type: none"> <li>1. Choix véhicule</li> <li>2. Aller dans le diagnostic - codage</li> <li>3. Activer/désactiver le diagnostic</li> <li>4. Sélectionner le BUS d'interface de diagnostic</li> <li>5. Suivre les instructions</li> </ol> <p><b>Véhicules avec systèmes d'aide</b></p> <ol style="list-style-type: none"> <li>6. Effectuer une adaptation d'attelage aux systèmes d'aide</li> <li>7. Suivre les instructions</li> <li>8. Diagnostic</li> <li>9. Lire la mémoire de défaut et effacer les codes d'erreur éventuellement mémorisés</li> <li>10. Terminé</li> </ol>
(I)	(E)	(NL)
<p><b>Per attivare le funzioni del rimorchio, procedere nel modo seguente:</b></p> <ol style="list-style-type: none"> <li>1. Scelta vettura</li> <li>2. Passare alla Diagnosi - Codifica</li> <li>3. Attivare / disattivare il gancio di traino</li> <li>4. Selezionare il interfaccia di diagnosi</li> <li>5. Seguire le istruzioni</li> </ol> <p><b>Veicoli noc suster di assistenza</b></p> <ol style="list-style-type: none"> <li>6. adattare i suster installati</li> <li>7. Seguire le istruzioni</li> <li>8. Diagnosi</li> <li>9. Leggere la memoria guasti e cancellare, se necessario</li> <li>10. Fertig</li> </ol>	<p><b>La activación de las funciones de remolque debe la siguiente manera:</b></p> <ol style="list-style-type: none"> <li>1. Selección de vehículo</li> <li>2. Cambiar a diagnosis - Codificación</li> <li>3. Desactivar/ activar acoplamiento para remolque</li> <li>4. Selecciona diagnosis Interface Bus</li> <li>5. Seguir las instrucciones</li> </ol> <p><b>En vehículos noc sistemas de asistencia</b></p> <ol style="list-style-type: none"> <li>6. Ejecutar adaptación de acoplamiento para remolque a suster de asistencia</li> <li>7. Seguir las instrucciones</li> <li>8. Diagnosis</li> <li>9. Leer memoria de averias y borrarla si es necesario</li> <li>10. Listo</li> </ol>	<p><b>De activering van de aanhangerfuncties moet als volgt worden uitgevoerd:</b></p> <ol style="list-style-type: none"> <li>1. Voertuigselectie</li> <li>2. Ga naar Diagnose - Codering</li> <li>3. Aanhangwagenkoppeling deactiveren/activeren</li> <li>4. Diagnose interface bus selecteren</li> <li>5. Volg instructie op</li> </ol> <p><b>Bij voertuigen met assistentiesystemen</b></p> <ol style="list-style-type: none"> <li>6. „Aanhangwagenkoppeling aanpassen aan assistentiesystem“ uitvoeren</li> <li>7. Volg instructie op</li> <li>8. Diagnose</li> <li>9. Foutcodegeheugen uitlezen en indien nodig wissen</li> <li>10. Gereed</li> </ol>

# 52 CHECK

# OPTION vehicle coding

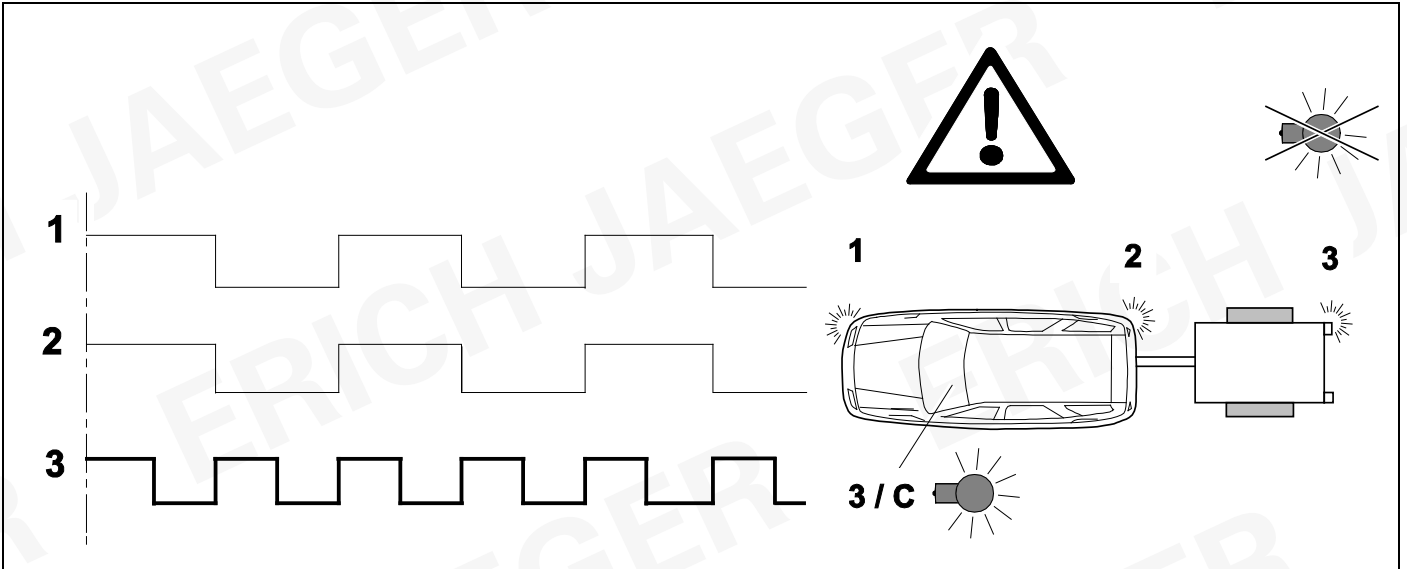

# 53

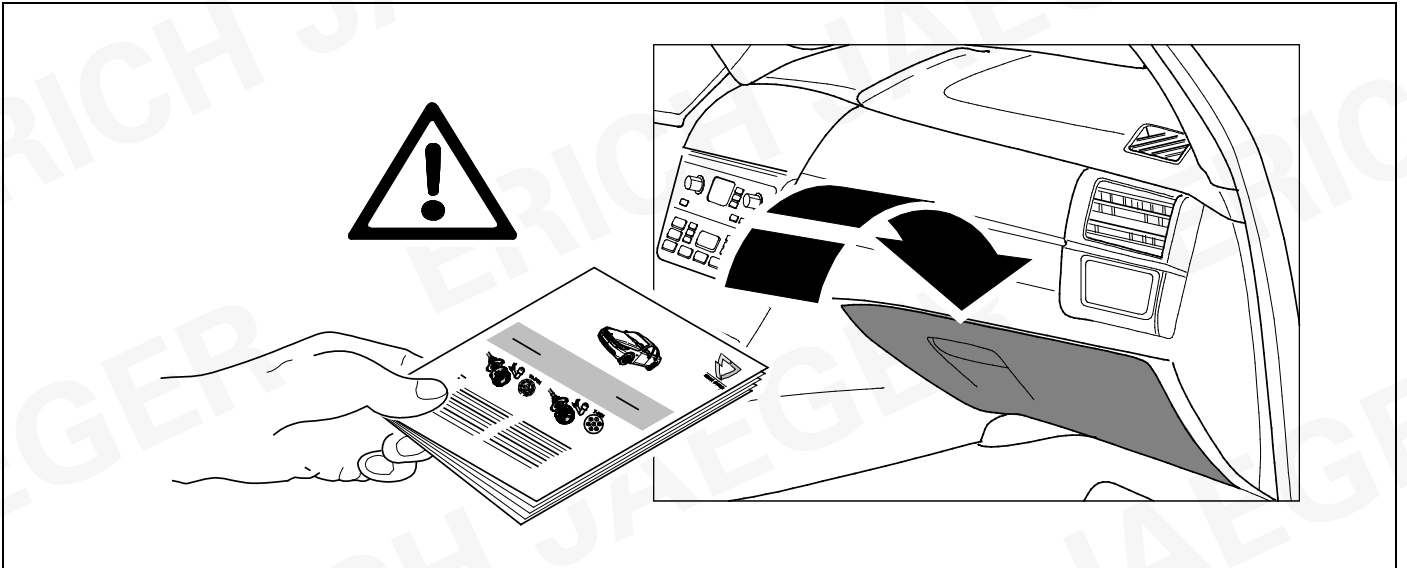

# 54

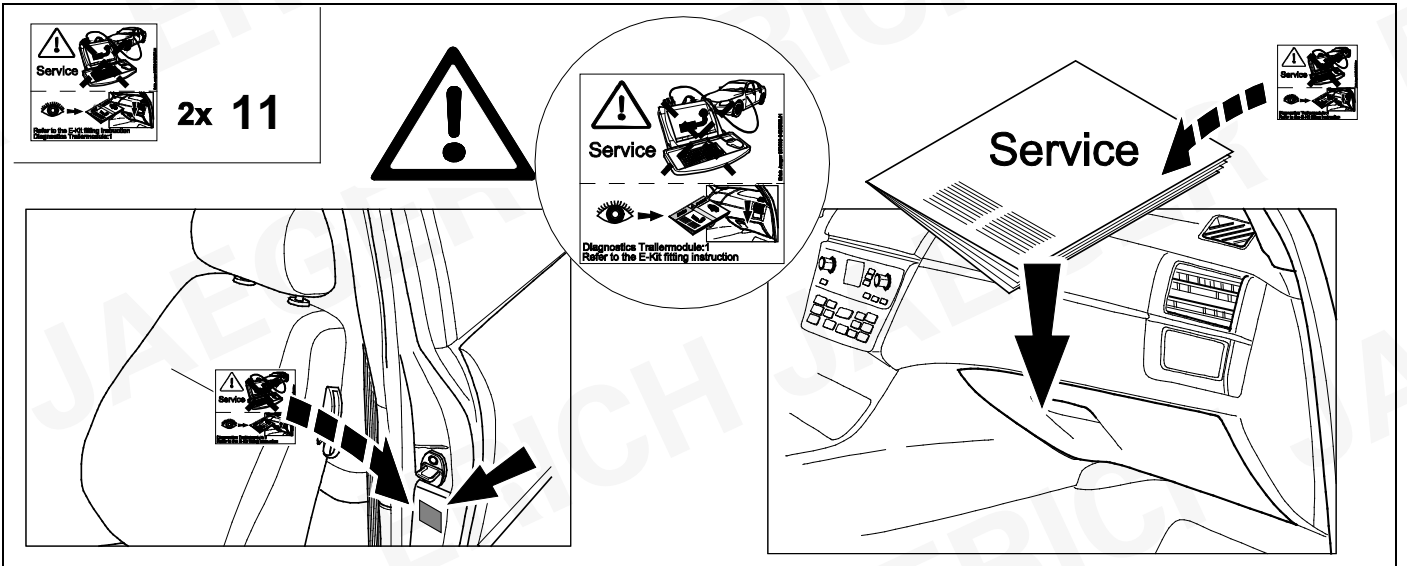

<b>D</b>	Änderungen bezüglich Konstruktion, Ausstattung Farbe sowie Irrtum vorbehalten. Angaben und Abbildungen unverbindlich	<b>PL</b>	Zastrzega się prawo do zmian dot. konstrukcji, wykończenia, kolorystyki oraz pomylek. Dane i ilustracje niewiążące.
<b>GB</b>	Subject to change in terms of construction, equipment and colour, and may contain errors. The information and illustrations are non-binding.	<b>TR</b>	Tasarım, donanım ve renk bakımından değişiklik yapma hakkı ve hata ve eksiklik mahfuzdur. Veriler ve resimler bağlayıcı değildir.
<b>F</b>	Sous réserve de modifications de la construction, de l'équipement, de la couleur et sous réserve d'erreurs. Les indications et les illustrations sont sans engagement.	<b>H</b>	A szerkezet, a kivétel és a szín változtatása, valamint a változások joga fenntartva. Az adatok és az ábrák nem kötelező érvényűek.
<b>NL</b>	Wijzigingen met betrekking tot constructie, uitvoering en kleur evenals vergissingen voorbehouden. Gegevens en afbeeldingen niet bindend.	<b>HR</b>	Pravo promjena u svezi konstrukcije, opreme, boje kao i zabune oridžavamo. Podaci i ilustracije su neobavezne.
<b>DK</b>	Ændringer med hensyn til konstruktion, udstyr, farver samt fejl forbeholdes. Oplysninger og illustrationer er uforpligtende.	<b>BUL</b>	Запазени права по отношение на конструкцията, обзавеждането, цвета и грешки. Данните и изображенията не са обвързващи.
<b>N</b>	Ændringer angående konstruksjon, utstyr, farge og feiltagelse forbeholdes. Oplysninger og illustrasjoner uforbindtlig.	<b>RO</b>	Ne rezervăm dreptul unor modificări ale construcției, dotării, culorii și dreptul la erori Datele indicate și imaginile sunt orientative.
<b>S</b>	Med reservation för ändringar vad det gäller konstruktion, utrustning, färg samt för misstag. Uppgifterna och bilderna är inte bindande.	<b>RU</b>	Права на внесение изменений относительно конструкции, оснащения, окраски, а также на ошибки сохраняются. Данные и иллюстрации имеют примерный характер.
<b>FIN</b>	Pidätämme oikeuden rakennetta, varustusta, väriä koskeviin sekä erehdyksestä johtuviin muutoksiin. Tiedot ja kuvat eivät ole sitovia.	<b>LT</b>	Pasiliekaama konstrukcijos, įrangos bei reikmenų, spalvos pakeitimų ir klaidų teisė. Duomenys ir iliustracijos neįpareigojantys.
<b>I</b>	Con riserva di modifiche relative a progettazione, dotazione, colore ed errori. Le indicazioni e figure sono fornite senza impegno.	<b>LV</b>	Tiek paturētas tiesības uz konstrukcijas, iekārtu, krāsu izmaiņām, kā arī kļūdīšanās. Dati un attēli bez saistībām.
<b>E</b>	Reservadas las modificaciones respecto a diseño, equipamiento, color, así como error. Indicaciones y figuras sin compromiso.	<b>EST</b>	Konstruksiooni, varustuse ja võervi osas muudatused ning eksimine lubatud. Andmed ja joonised on mittesiduvad.
<b>P</b>	Reservamos o direito de alterações relativamente ao desenho, equipamento, cor, bem como de erro. Os dados e as gravuras não implicam compromisso da nossa parte.	<b>SLO</b>	Zadržana pravica do sprememb glede konstrukcije, opreme, barve ter pomote. Podatki in slike so neobvezne.
<b>GR</b>	Διατηρώνουμε κάθε επιφύλαξη ως προς αλλαγές σε σχέση με κατασκευή, εξοπλισμό, διαρρύθμιση, χρωματισμούς και λάθη παραδρομής.	<b>SK</b>	Zmeny, ktoré sa týkajú konštrukcie, vybavenia, farby, ako aj omyly sú vyhradené. Údaje a zobrazenia sú nezáväzné.
<b>CZ</b>	Změny, týkající se konstrukce, vybavení, barvy, jakož i omyly jsou vyhrazeny. Údaje a vyobrazení jsou nezávazné.		

**ERICH JAEGER Artikelnummer:**  
**ERICH JAEGER part number:**

**311069**

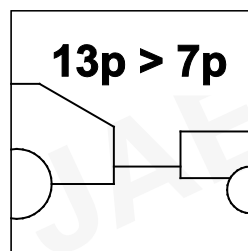
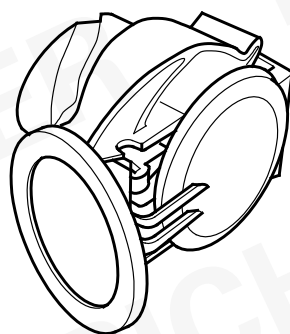

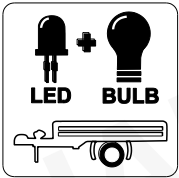

**Jaeger FLEX  
2in1**



ERICH JAEGER

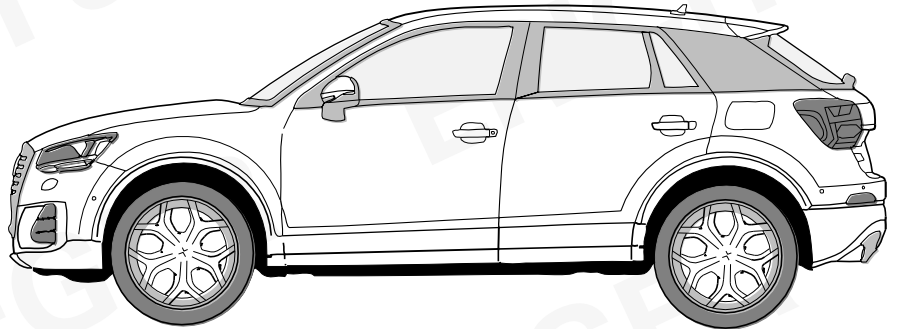

**AUDI Q2**

**11/16 >>**

**748343**

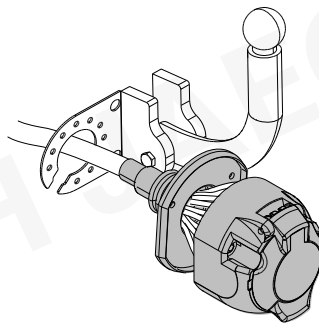

**13-PIN**

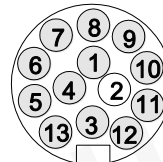

**ISO 11446**

- |  |   |
|--|---|
| <b>(D)</b> Einbauanleitung             | <b>(PL)</b> Instrukcja montażu                |
| <b>(GB)</b> Installation instructions  | <b>(TR)</b> Montaj talimatı                   |
| <b>(F)</b> Consignes de montage        | <b>(H)</b> Beépítési útmutató                 |
| <b>(NL)</b> Montagehandleiding         | <b>(HR)</b> Upute o ugradnji                  |
| <b>(DK)</b> Montagevejledning          | <b>(BUL)</b> Инструкция за монтаж             |
| <b>(N)</b> Monteringsinstruksjon       | <b>(RO)</b> Instrucțiuni de montaj            |
| <b>(S)</b> Installationsanvisning      | <b>(RU)</b> Инструкция по монтажу и установке |
| <b>(FIN)</b> Asennusohje               | <b>(LT)</b> Montavimo informacija             |
| <b>(I)</b> Istruzioni per il montaggio | <b>(LV)</b> Iemontēšanas pamācība             |
| <b>(E)</b> Instrucciones de montaje    | <b>(EST)</b> Paigaldusjuhend                  |
| <b>(P)</b> Instruções de montagem      | <b>(SLO)</b> Navodilo za vgradnjo             |
| <b>(GR)</b> Οδηγίες εγκατάστασης       | <b>(SK)</b> Montážny návod                    |
| <b>(CZ)</b> Návod k montáži            |   |



# KIT

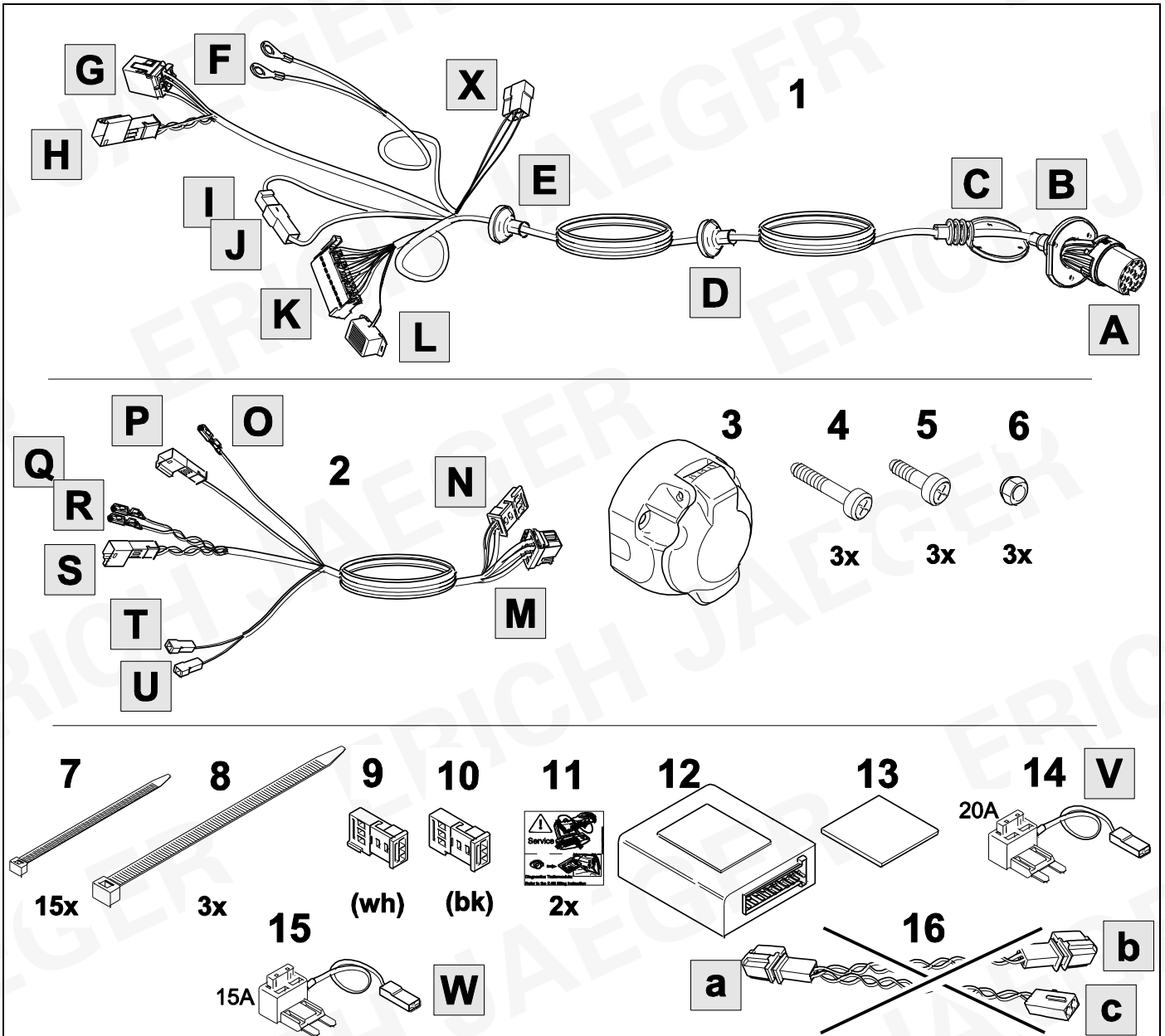

# TOOLS

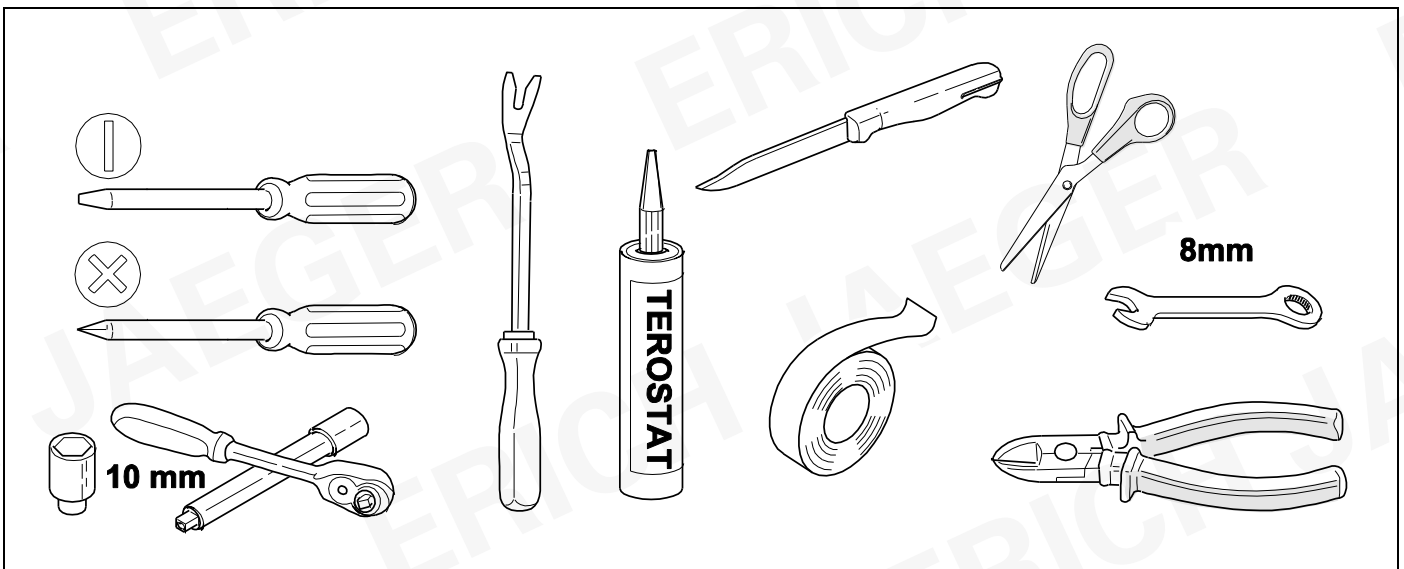

1

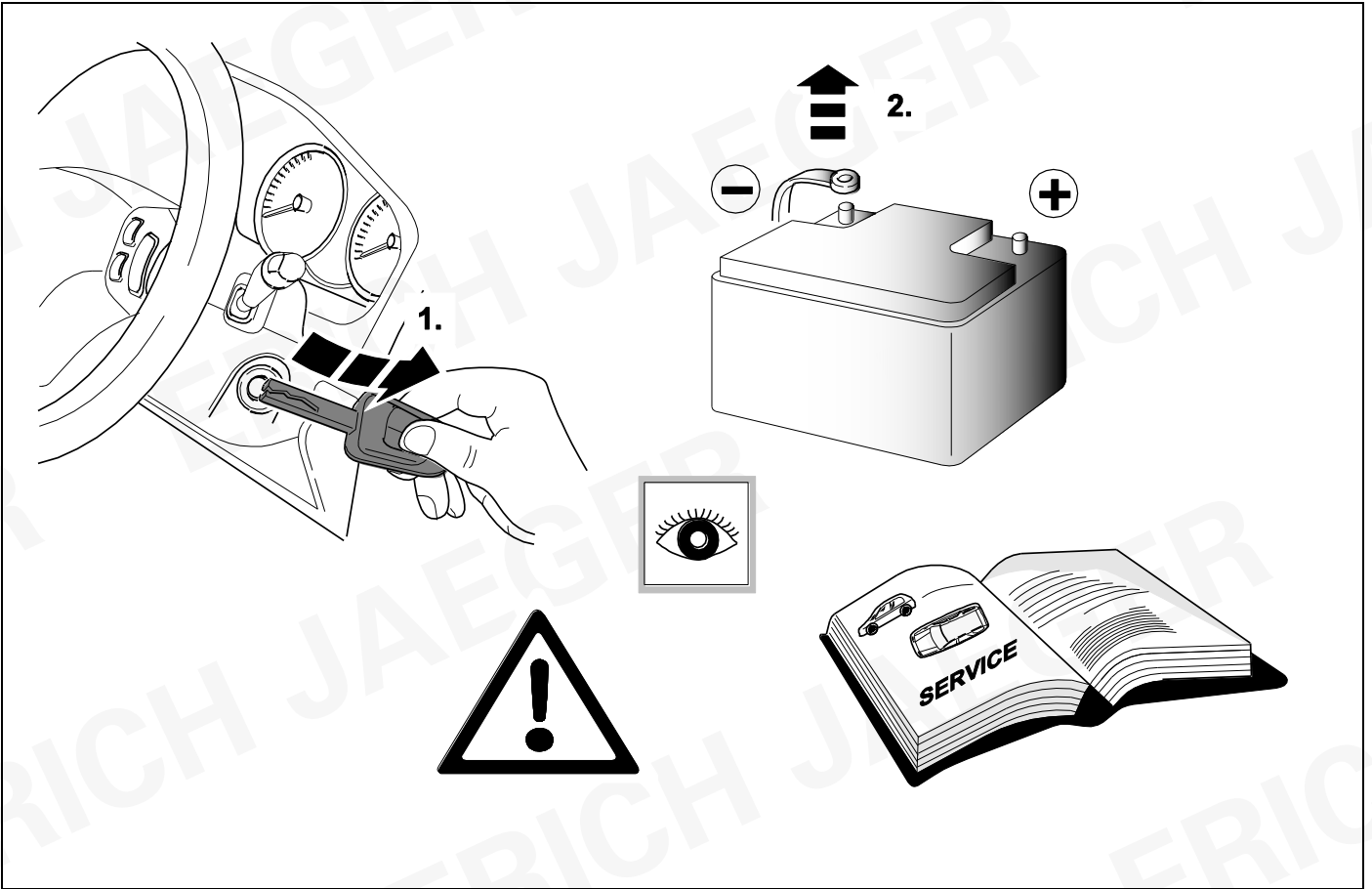

## 2 REMOVE

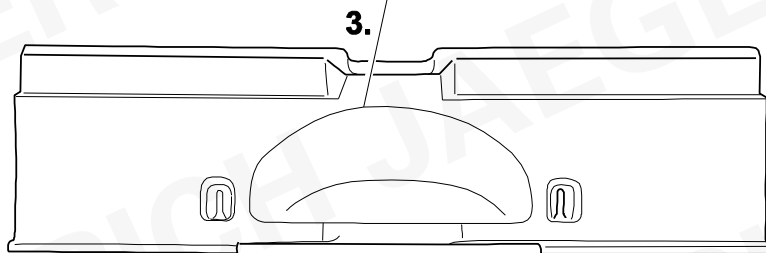
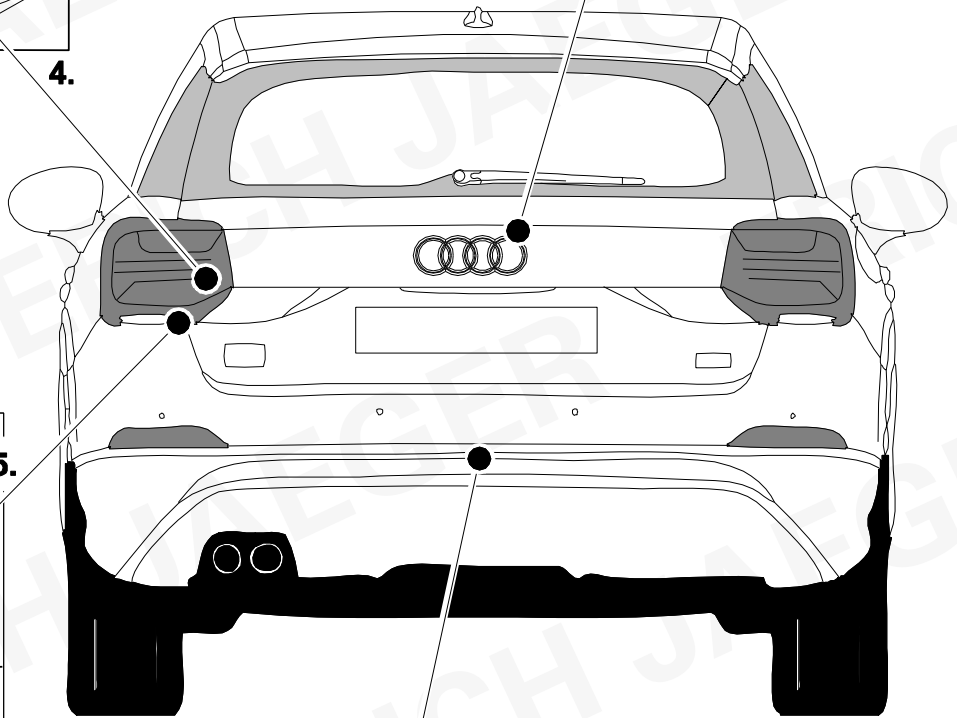
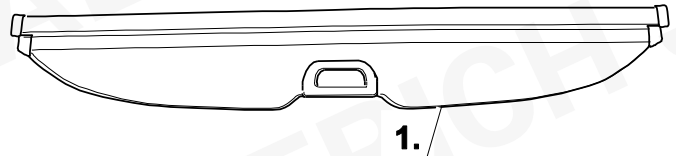
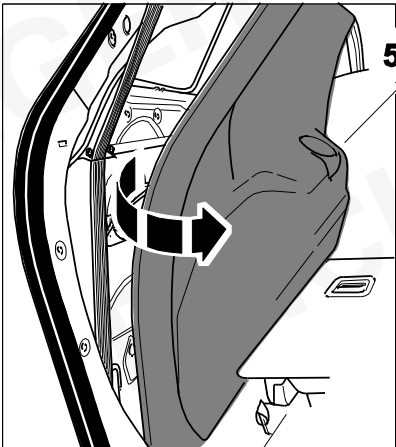
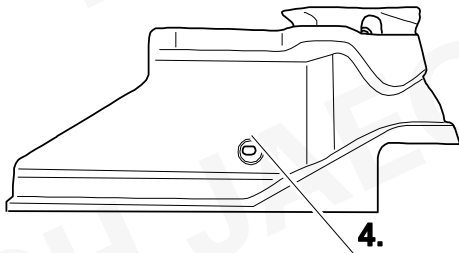
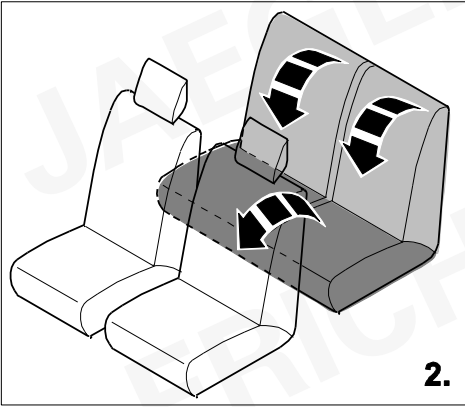



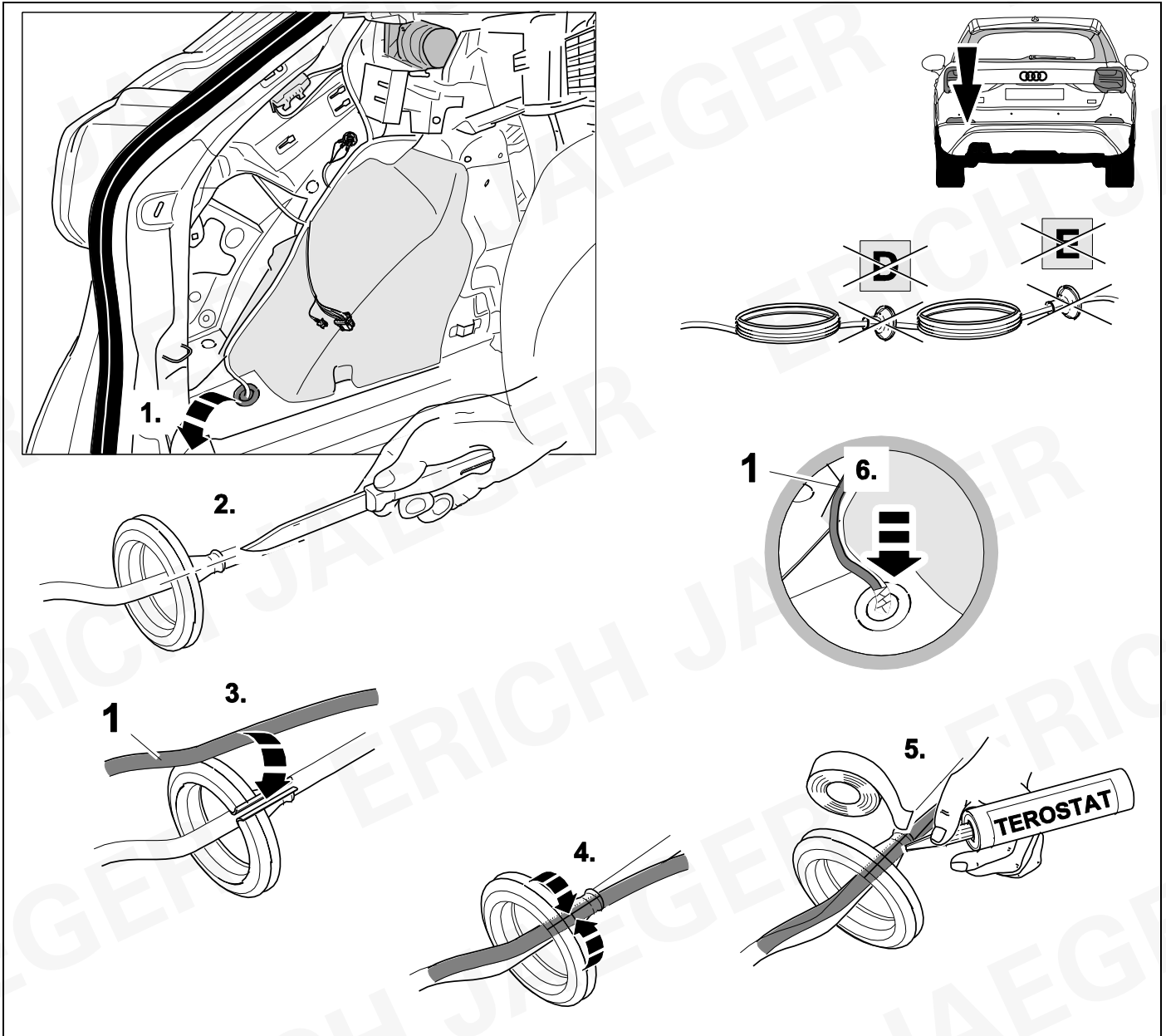

4

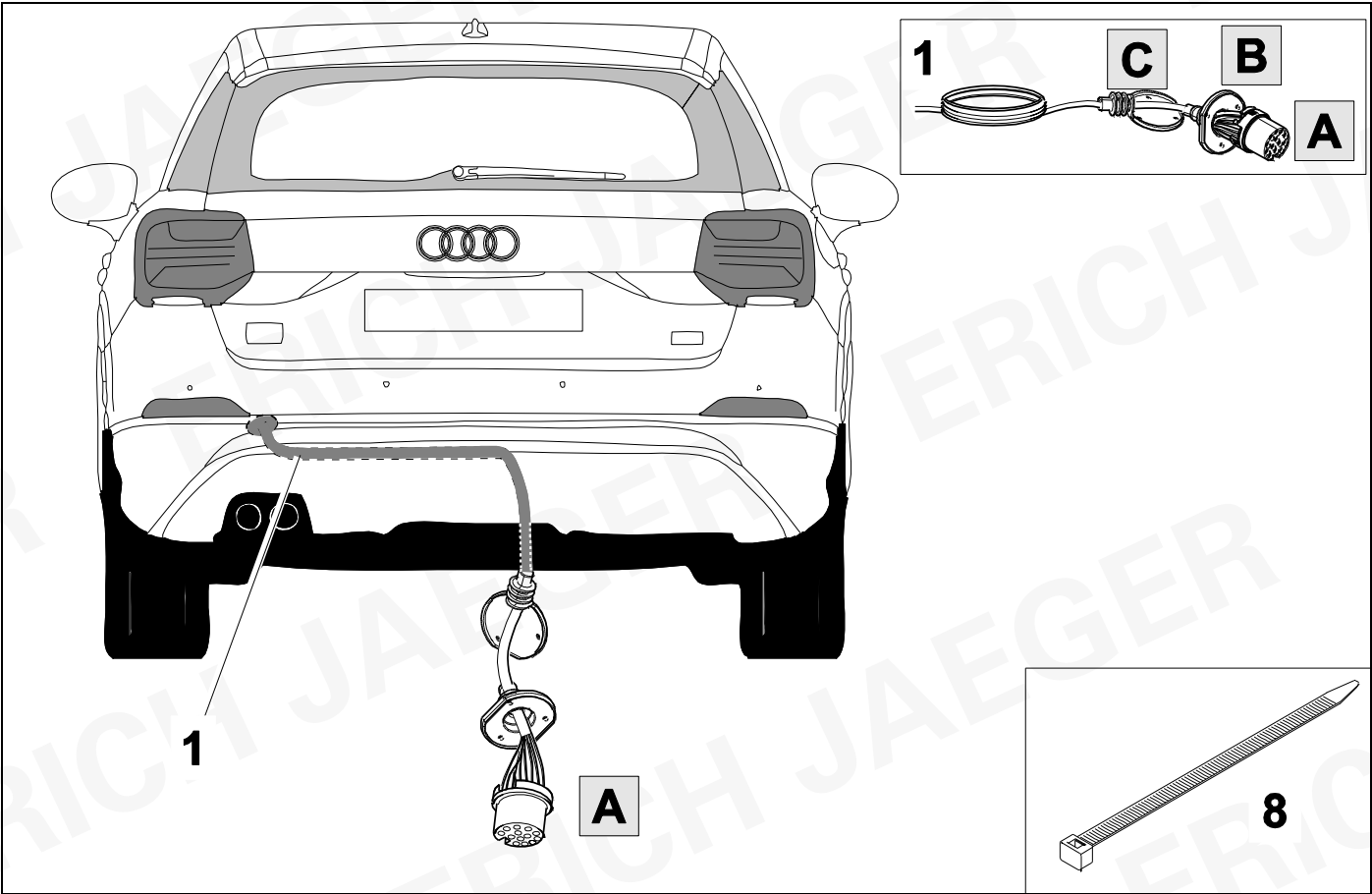

5

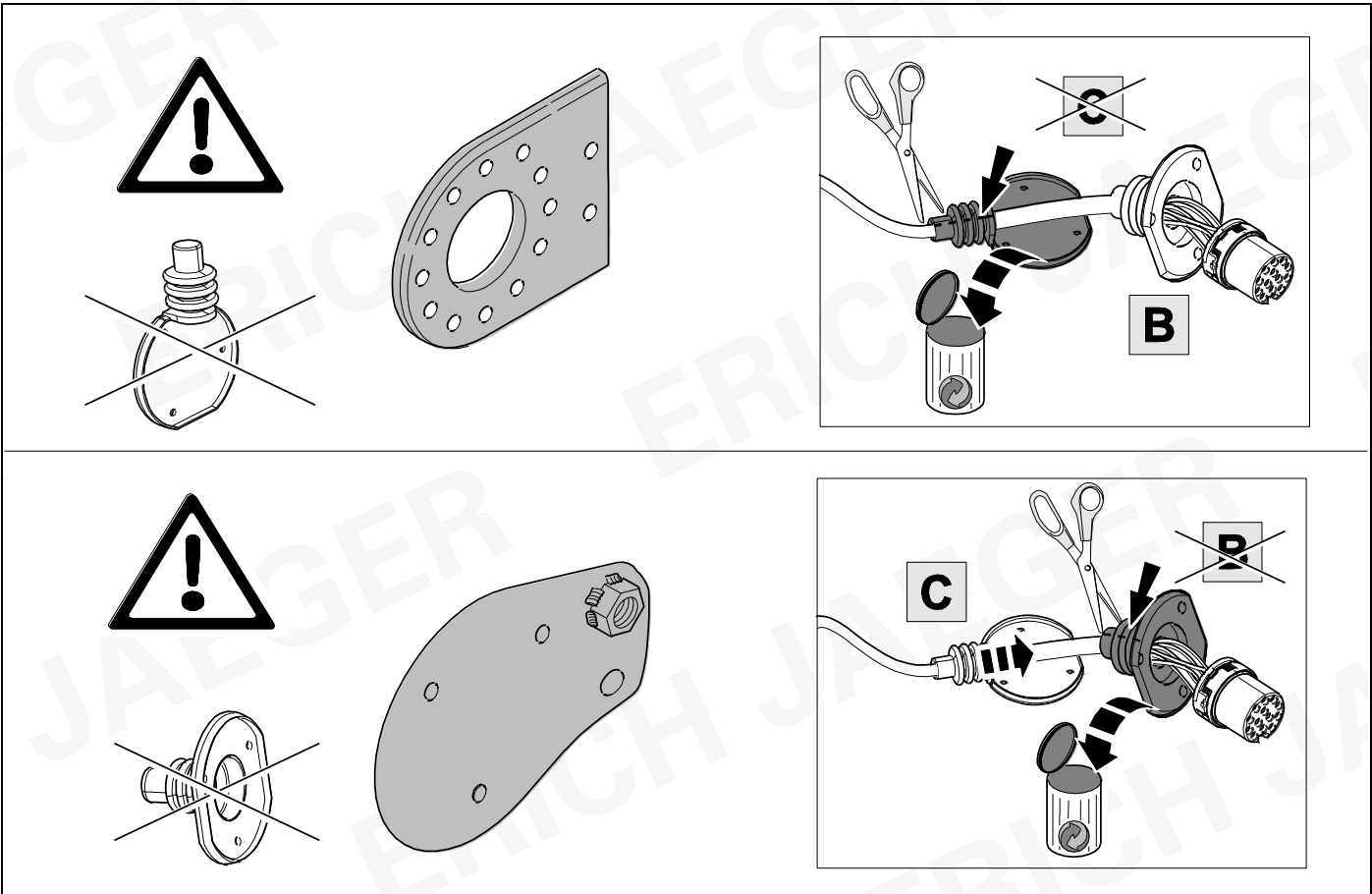

6



8

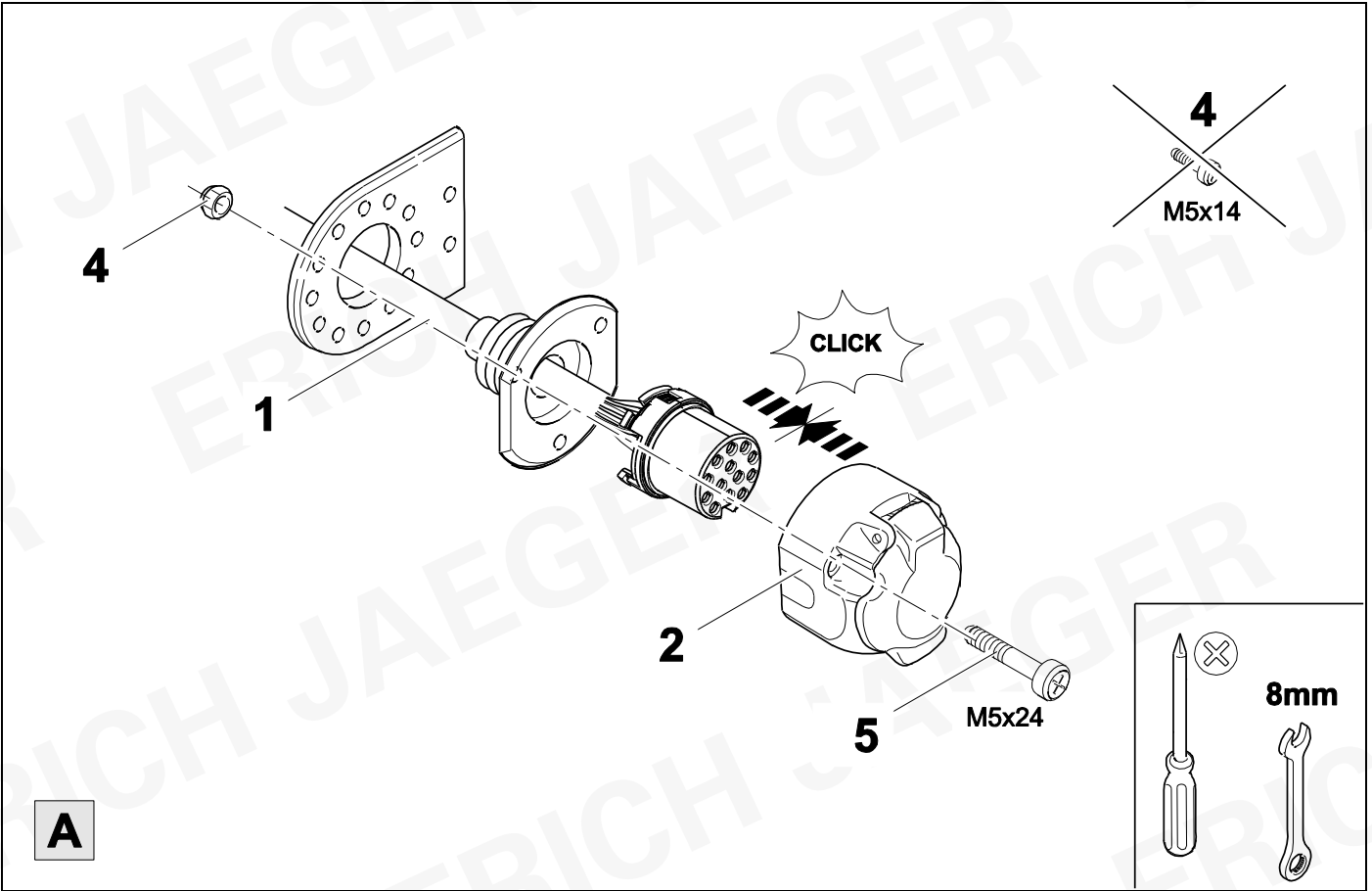

7



8

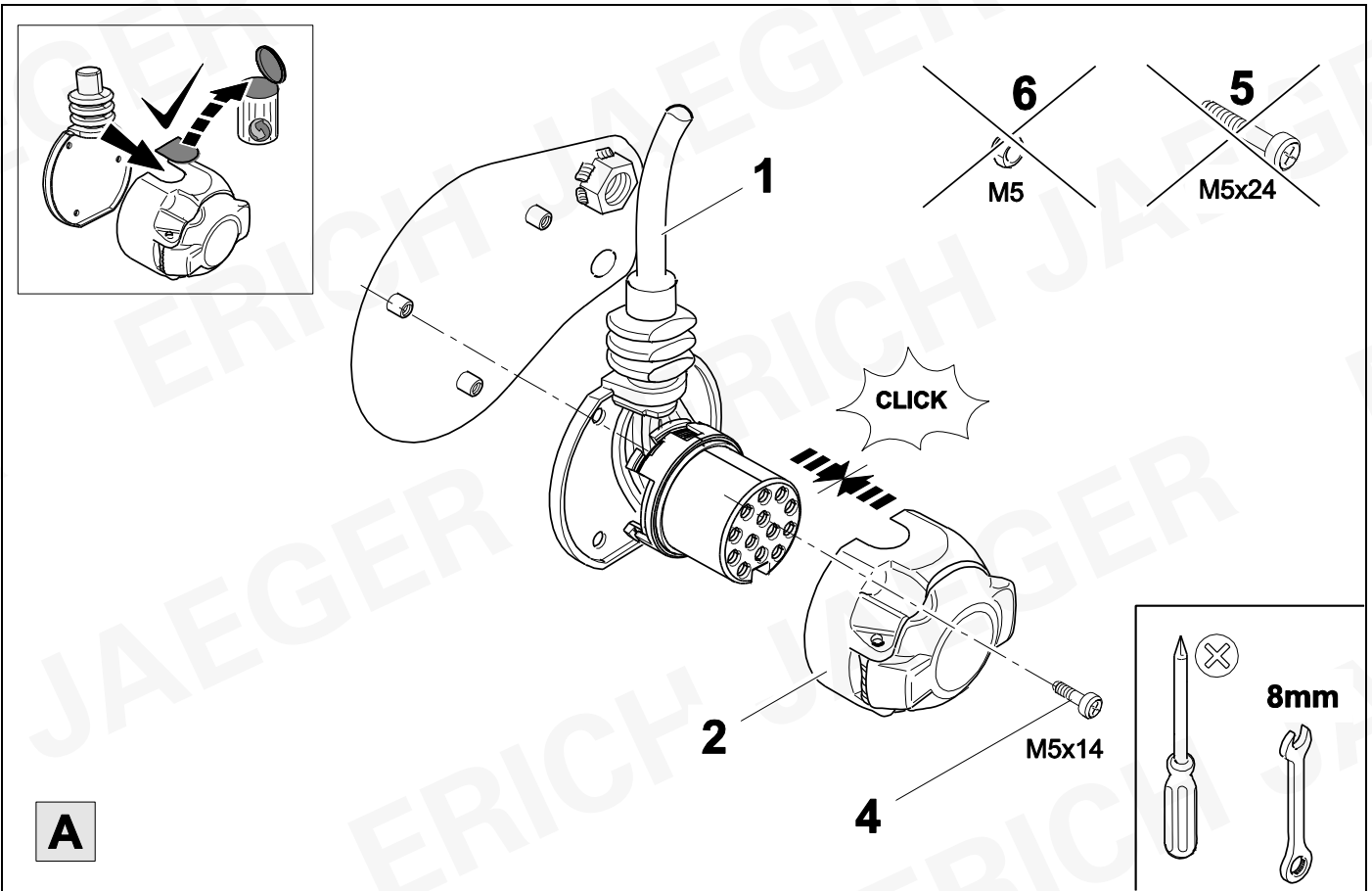

8



9

1	bk/wh		8	bu/rd	
2	gy		9	rd/bu	
3	wh/bn		10	ye	
4	bk/gn		11	bn/gn	
5	gy/rd		12	no	
6	bk/rd		13	bn	
7	gy/bk				

9	bk	wh	gy	gn	rd	bu	ye	bn	pu	or	no
<b>(D)</b>	schwarz	weiß	grau	grün	rot	blau	gelb	braun	violett	orange	nicht belegt
<b>(GB)</b>	black	white	grey	green	red	blue	yellow	brown	purple	orange	not occupied
<b>(F)</b>	noir	blanc	gris	vert	rouge	bleu	jaune	brun	violet	orange	inutilisé
<b>(NL)</b>	zwart	wit	grijs	groen	rood	blauw	geel	bruin	violet	oranje	niet aangesloten
<b>(DK)</b>	sort	hvid	grå	grøn	rød	blå	gul	brun	violet	orange	ikke anvendt
<b>(N)</b>	svart	hvit	grå	grønn	rød	blå	gul	brun	fiolett	oransje	ikke i bruk
<b>(S)</b>	svart	vit	grå	grön	röd	blå	gul	brun	violett	orange	ej använd
<b>(FIN)</b>	musta	valkoinen	harmaa	vihreä	punainen	sininen	keltainen	ruskea	violetti	oranssi	ei varattu
<b>(I)</b>	nero	bianco	grigio	verde	rosso	blu	giallo	marrone	viola	arancione	libero
<b>(E)</b>	negro	blanco	gris	verde	rojo	azul	amarillo	marrón	violeta	anaranja-do	no ocupado
<b>(P)</b>	preto	branco	cinzento	verde	vermelho	azul	amarelo	castanho	violeta	laranja	não ocupado
<b>(GR)</b>	μαύρος	λευκός	Γκρι	πράσινος	κόκκινος	μπλε	κίτρινος	καφέ	Μωβ	πορτοκαλί	δεν είναι κατ'επιτημένος
<b>(PL)</b>	czarny	biały	szaro	zielony	czerwony	niebiesko	żółty	brazowy	fioletowy	pomarańczowy	wolny
<b>(CZ)</b>	černý	bílý	šedý	zelený	červený	modrý	žlutý	hnědý	fialový	oranžový	neobsazen
<b>(TR)</b>	siyah	beyaz	gri	yeşil	kırmızı	mavi	sarı	kahverengi	mor	portakal rengi	boş
<b>(H)</b>	fekete	fehér	szürke	zöld	piros	kék	sárga	barna	ibolyakék	narancssárga	nem foglalt
<b>(HR)</b>	crno	bijelo	sivo	zeleno	crveno	plavo	zuto	smeđe	ljubičasto	narandžasto	nije zauzeto
<b>(BUL)</b>	черен	бял	сив	зелен	червен	син	жълт	кафяв	виолетов	оранжев	свободно
<b>(RO)</b>	negru	alb	gri	verde	roșu	albastru	galben	maro	violet	portocaliu	liber
<b>(RU)</b>	черный	белый	серый	зеленый	красный	голубой	жёлтый	коричневый	пурпурный	оранжевый	свободно
<b>(LT)</b>	juoda	balta	pilka	žalia	raudona	mėlyna	geltona	ruda	purpurinė	oranžinė	laisva
<b>(LV)</b>	melna	balta	pelēka	zaļa	sarkana	zila	dzeltena	brūna	purpur-sarkana	oranža	brīvs
<b>(EST)</b>	must	valge	hall	roheline	punane	sinine	kollane	pruun	purpur-punane	oraanž	vaba
<b>(SLO)</b>	črna	bela	siva	zelena	rdeča	modra	rumena	smeđ	vijoličast	oranžen	ni zasedeno
<b>(SK)</b>	čierny	biely	šedý	zelený	červený	modrý	žltý	hnědý	fialový	pomaraňový	neobsadený

10

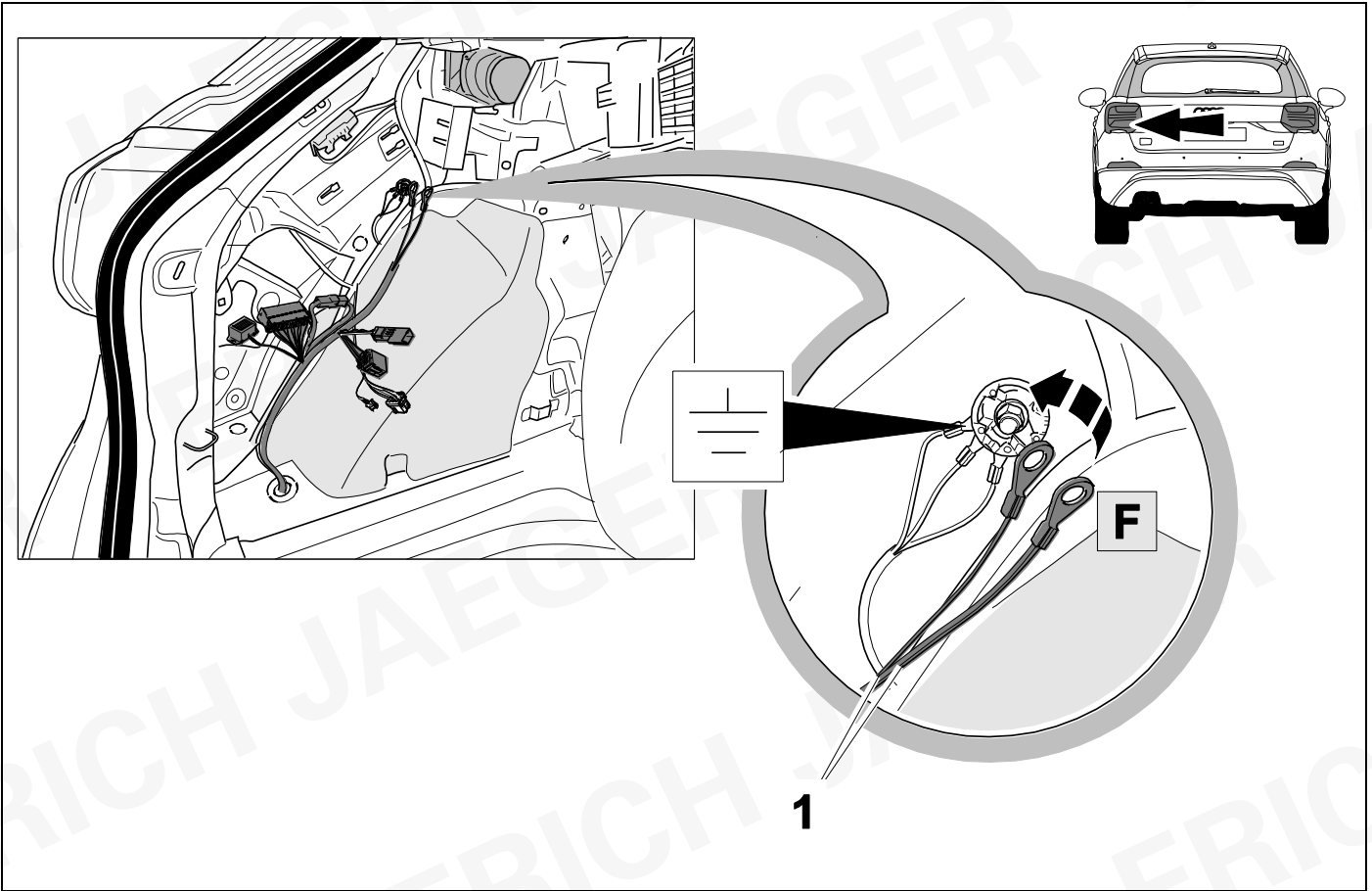

11



9

**Fahrzeuge mit Anhängervorbereitung**  
**Vehicles with trailer preparation**

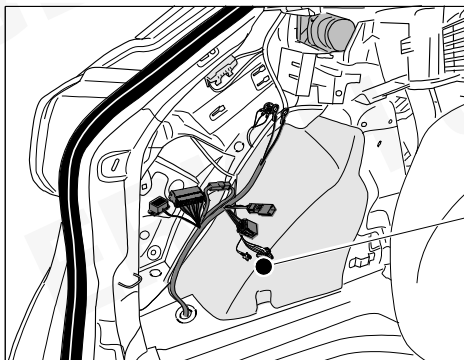

**OPTION 1**

12 ⇒ 17

35 ⇒ 47

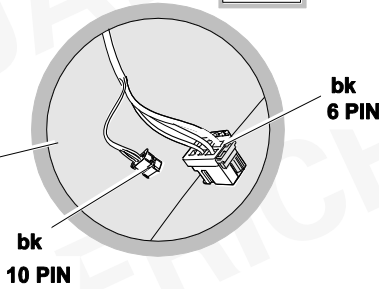

**Fahrzeuge ohne Anhängervorbereitung**  
**Vehicles without trailer preparation**

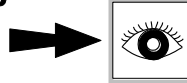
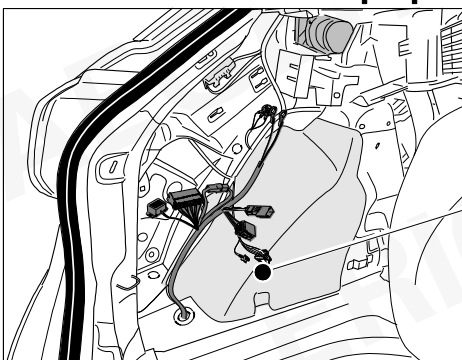

**OPTION 2**

18 ⇒ 47

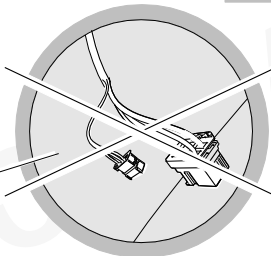

12



9

OPTION 1

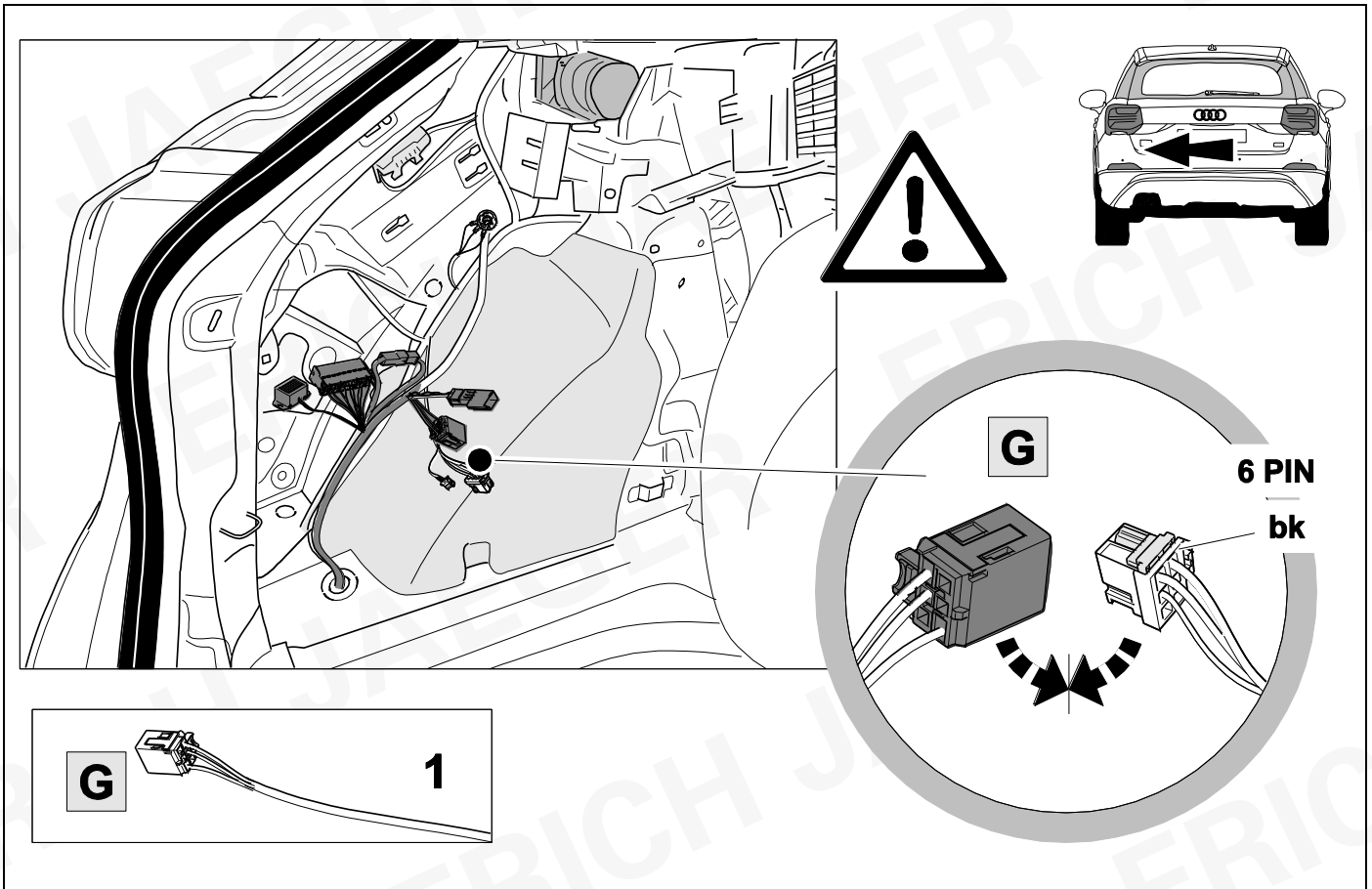

13



9

OPTION 1

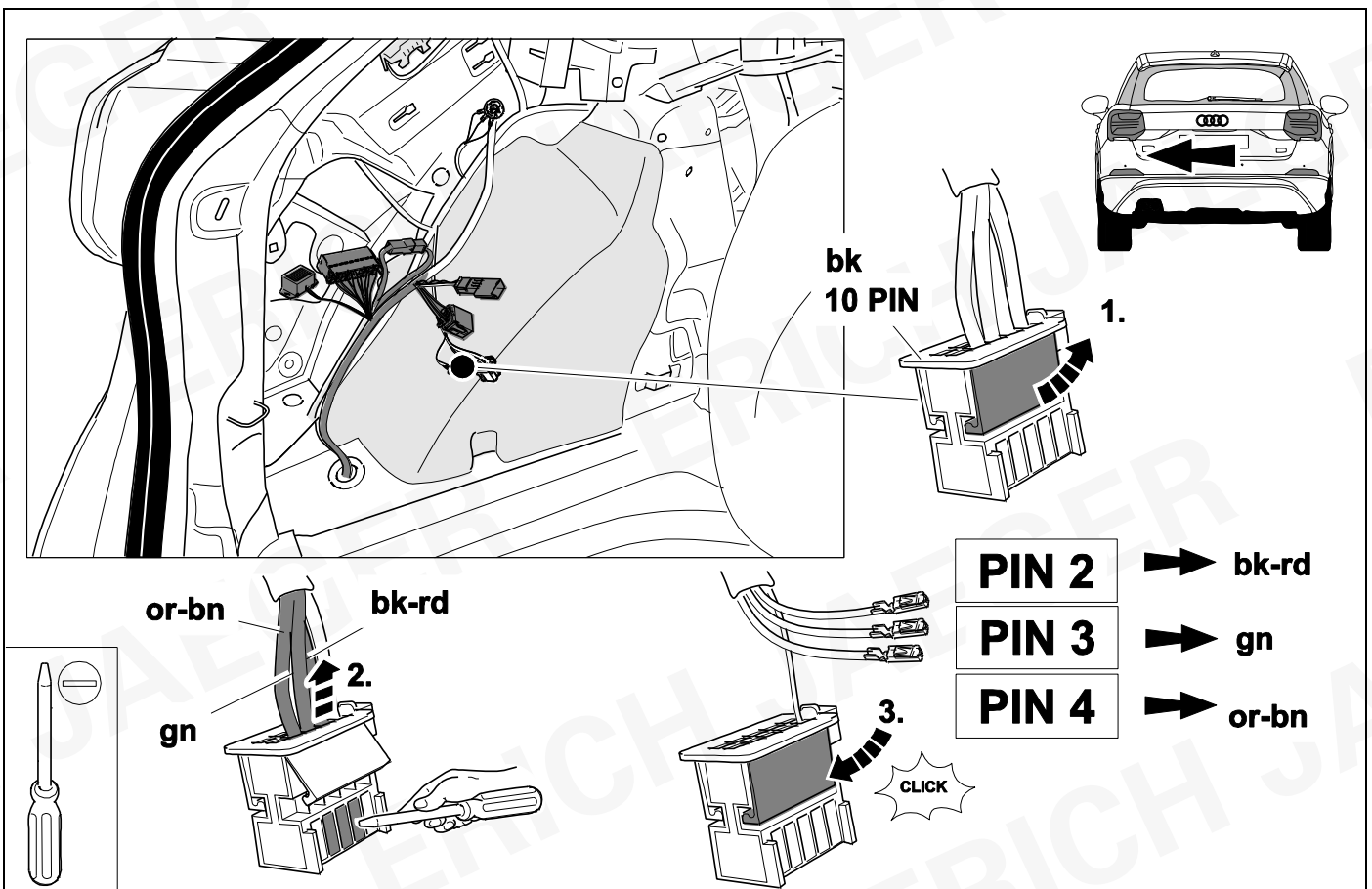

14

OPTION 1

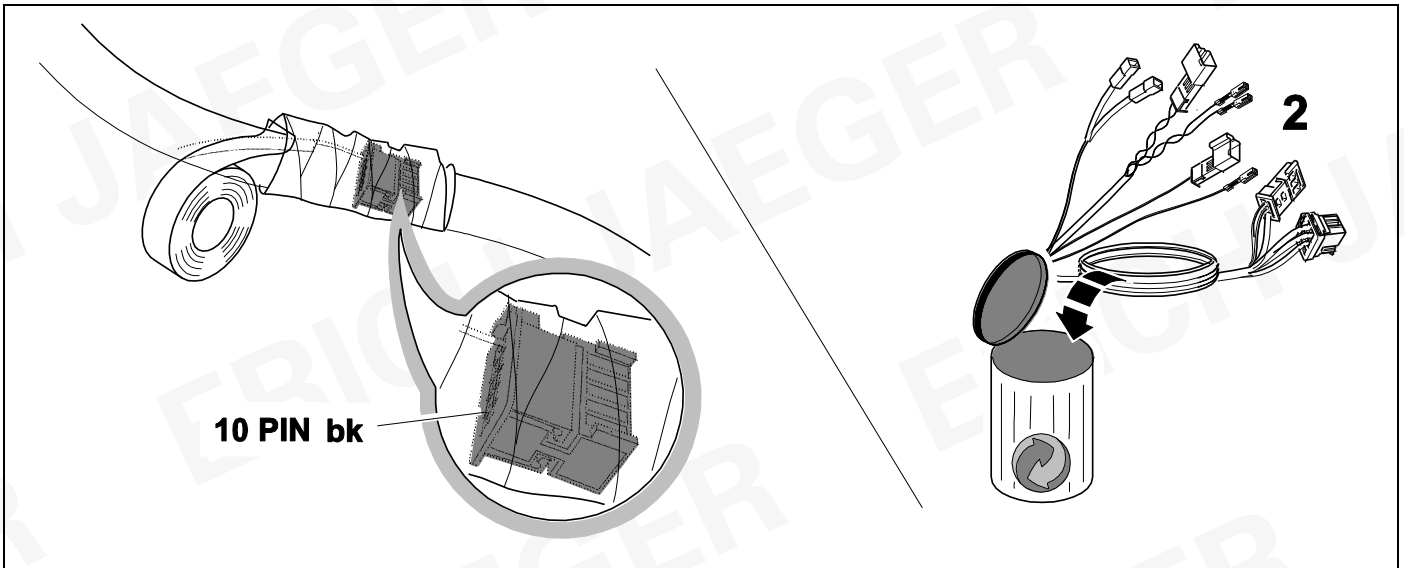

15



9

OPTION 1

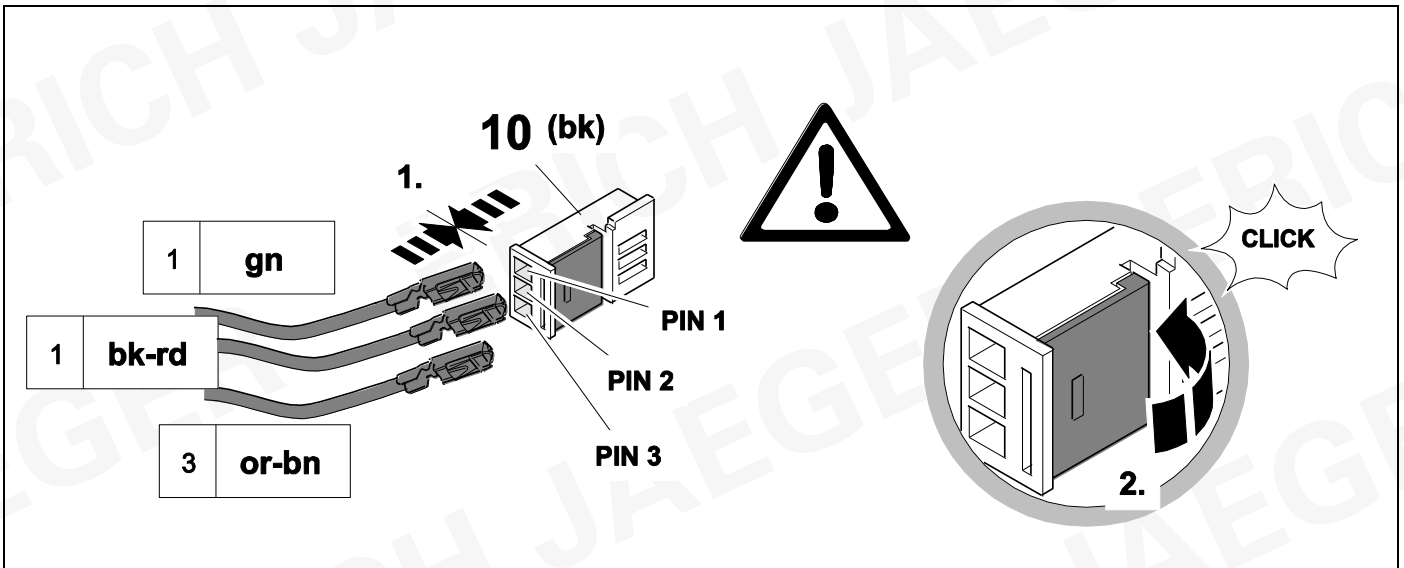

16



9

OPTION 1

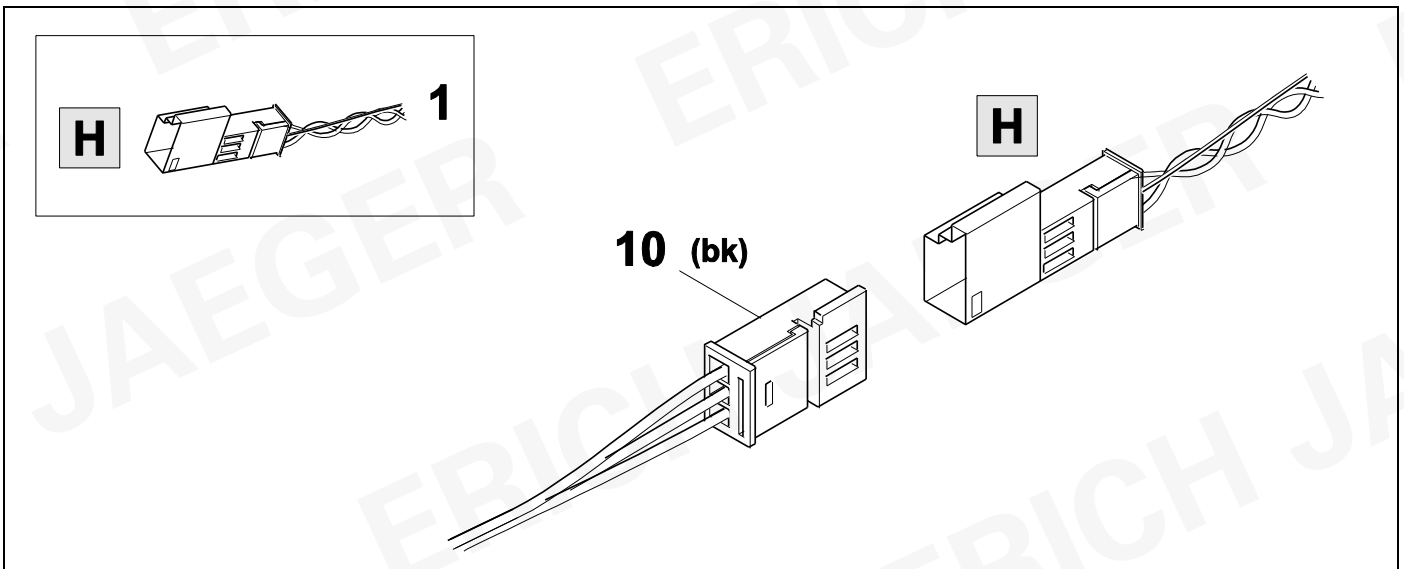

17

OPTION 1

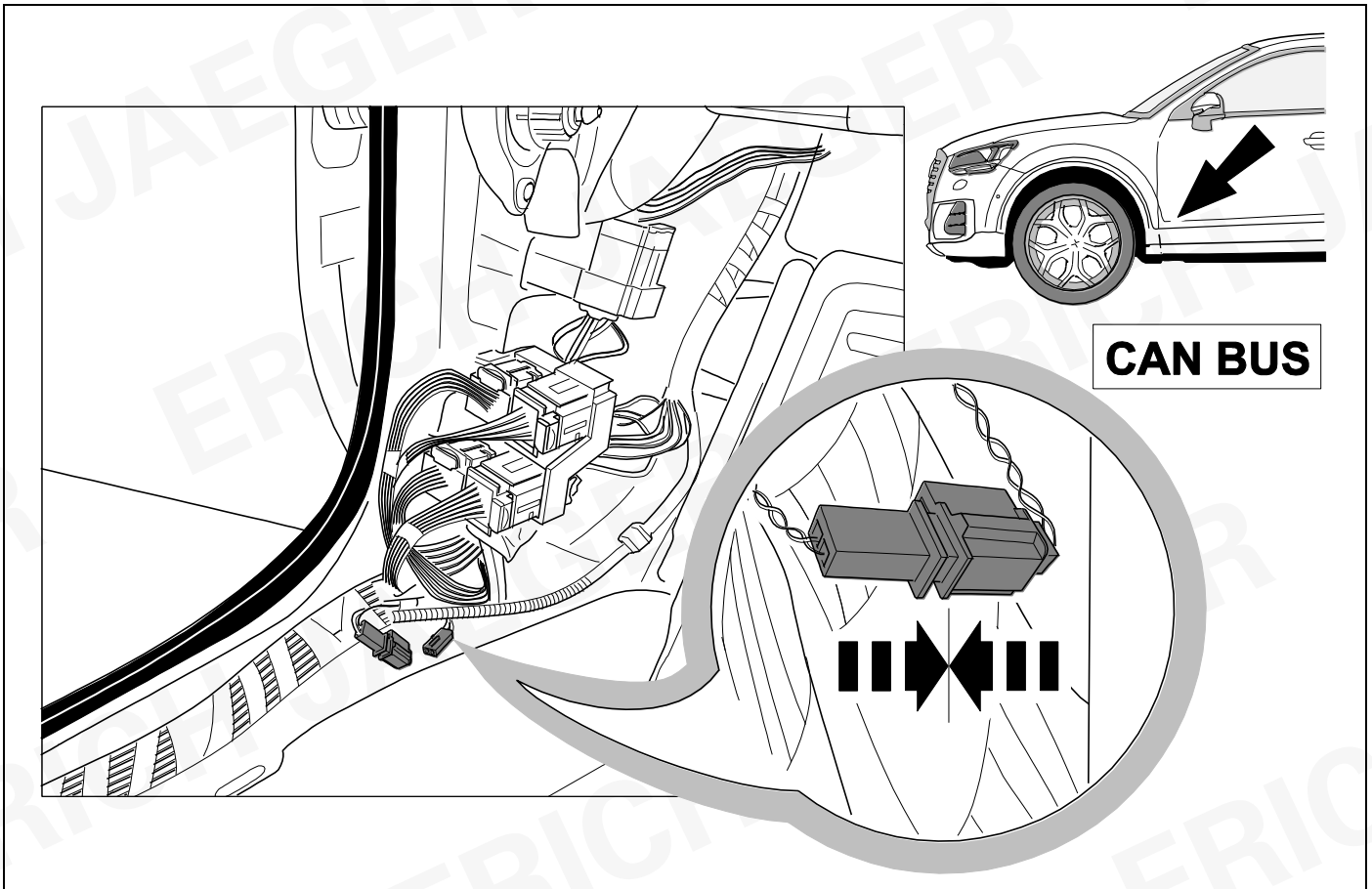

18 Vehicles without trailer preparation

OPTION 2

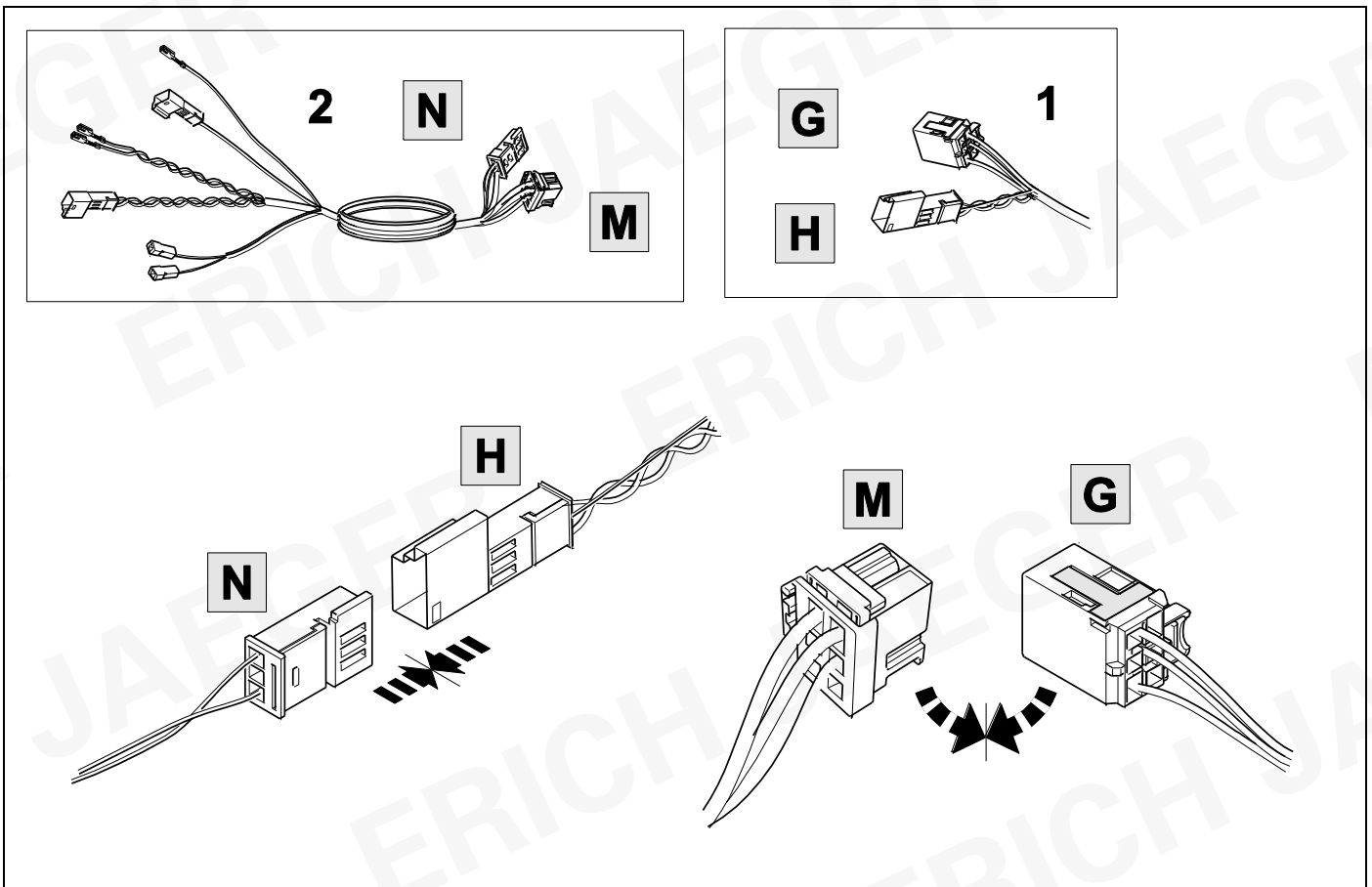



19

OPTION 2

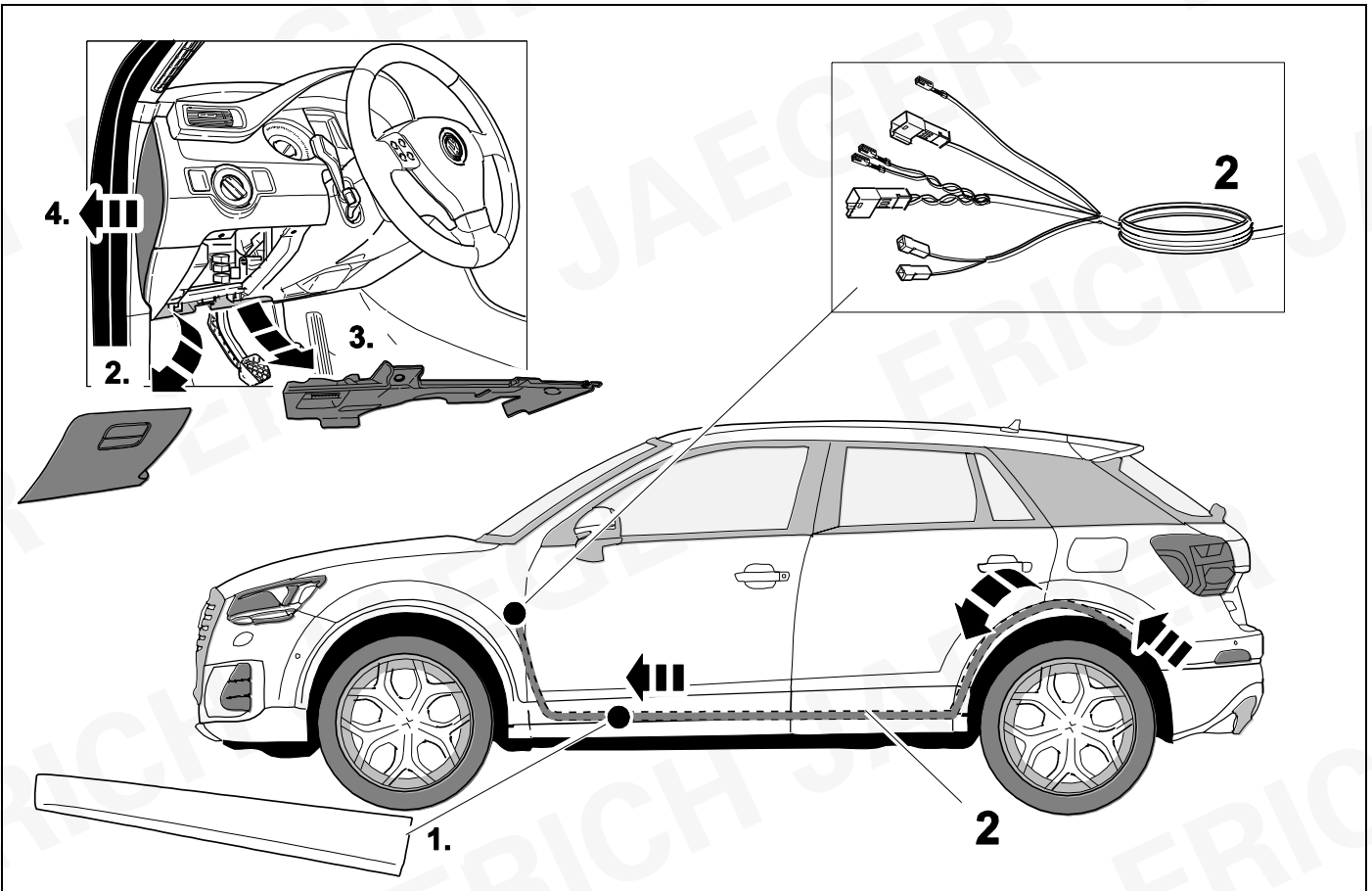

20

9 ⇒

OPTION 2

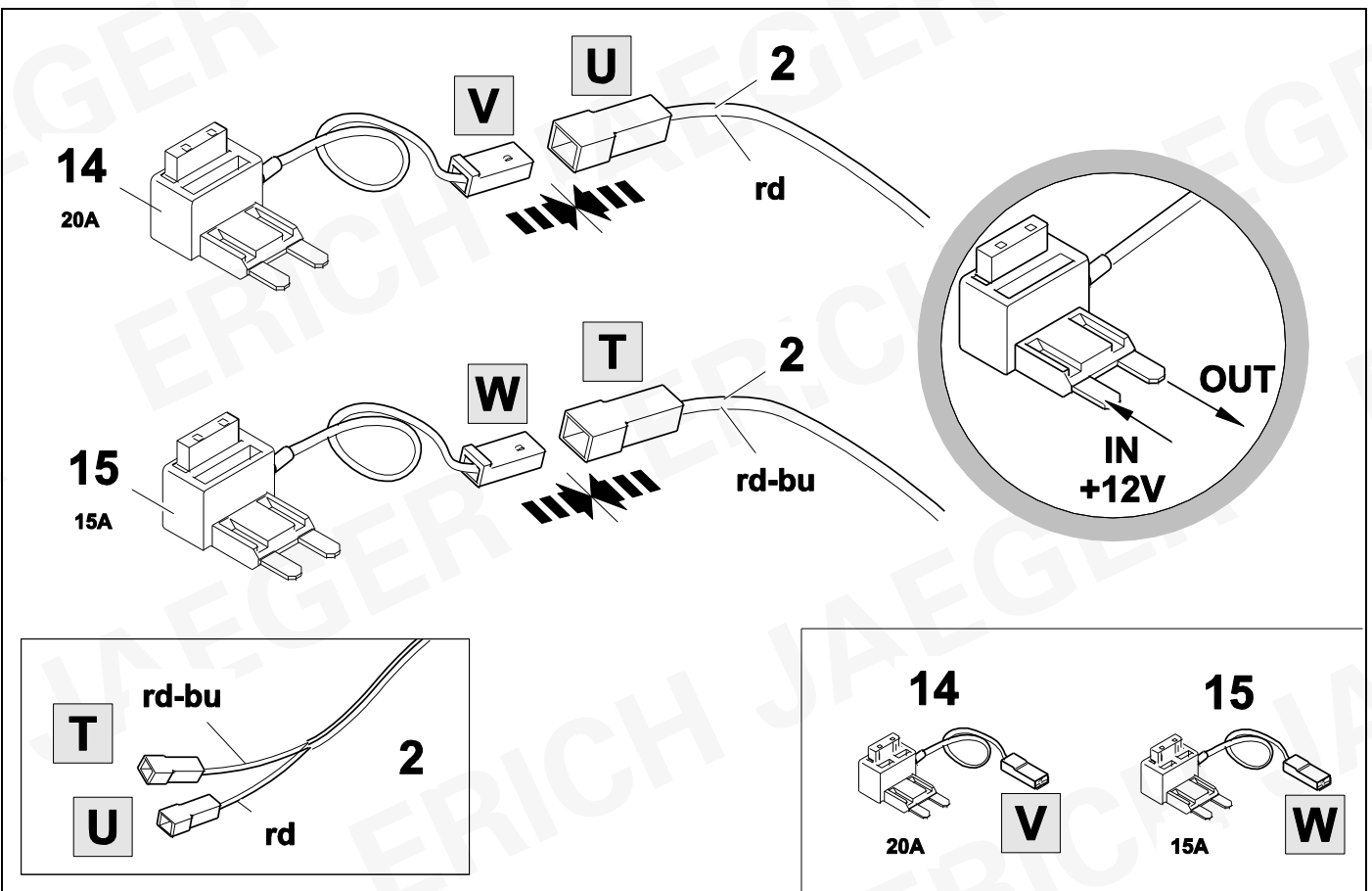

21



40

OPTION 2

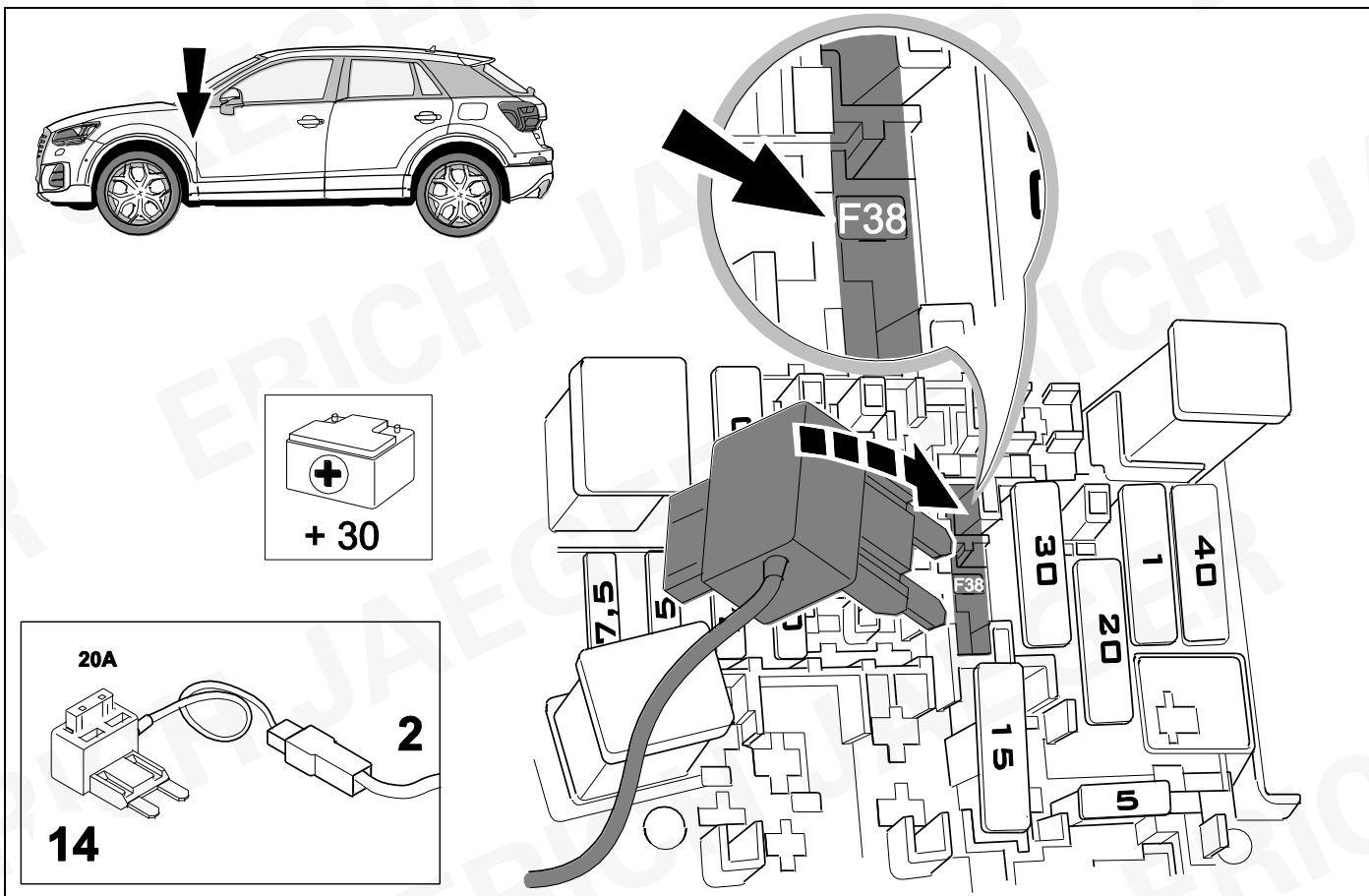

22



40

OPTION 2

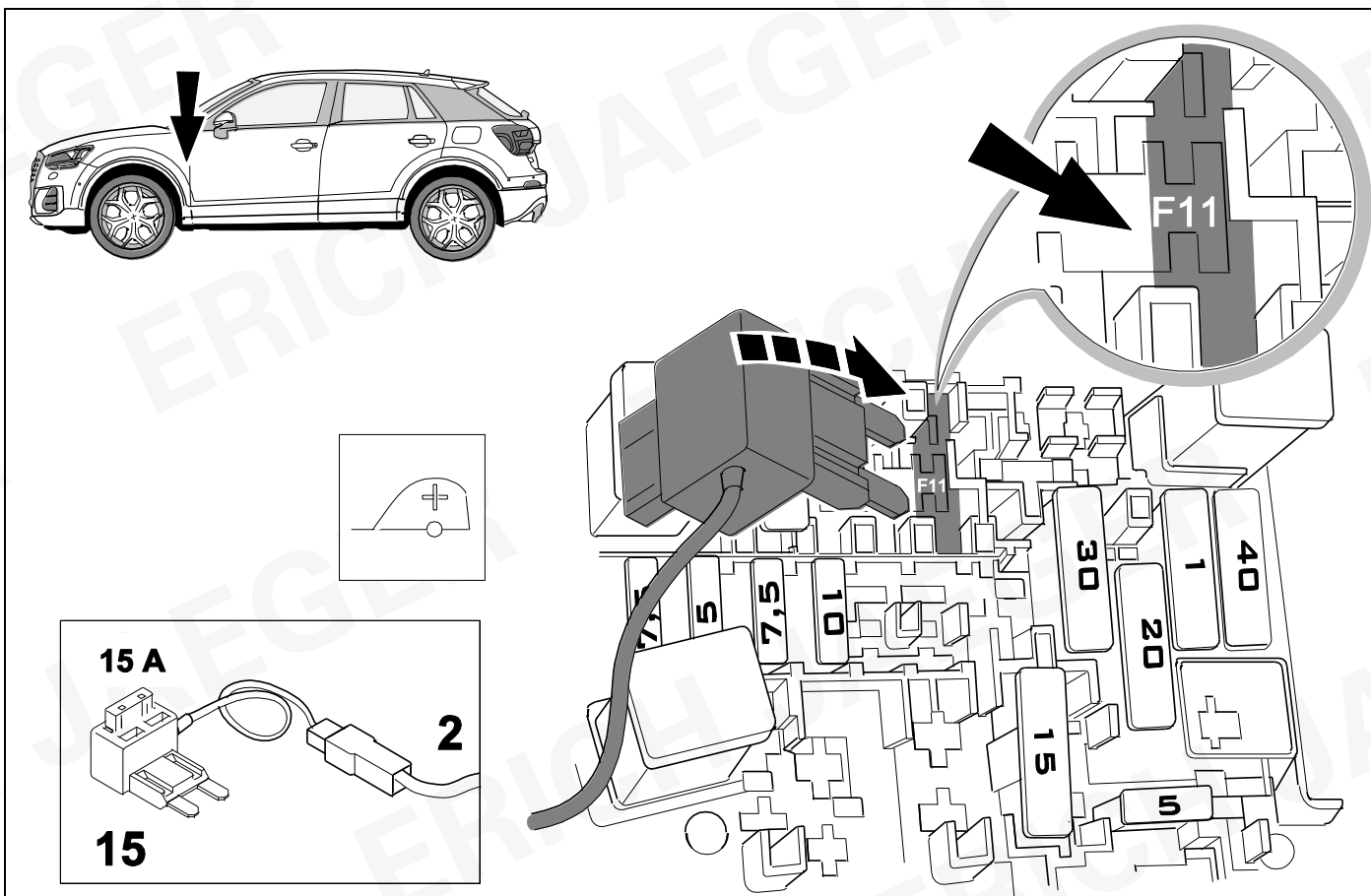

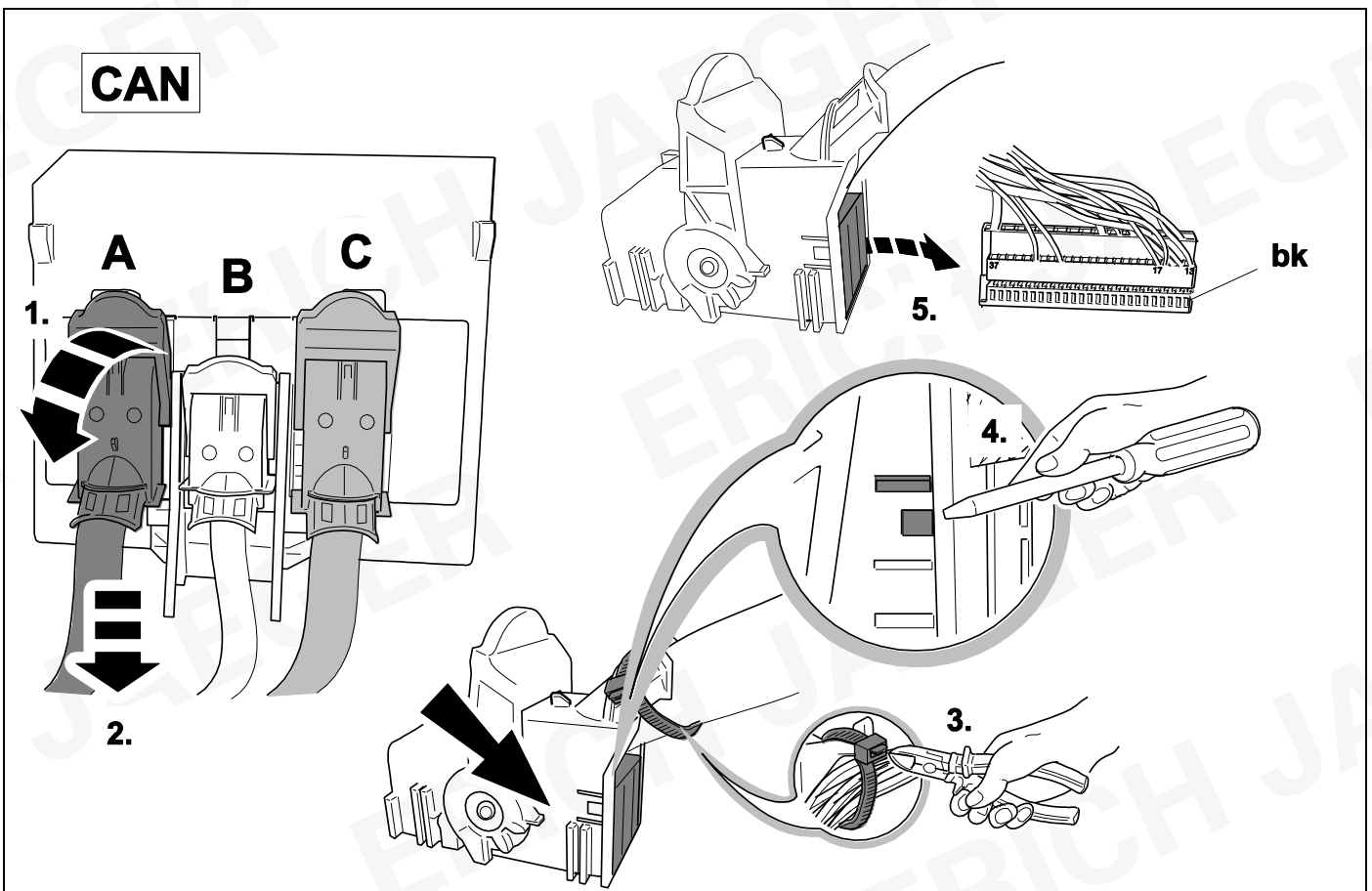
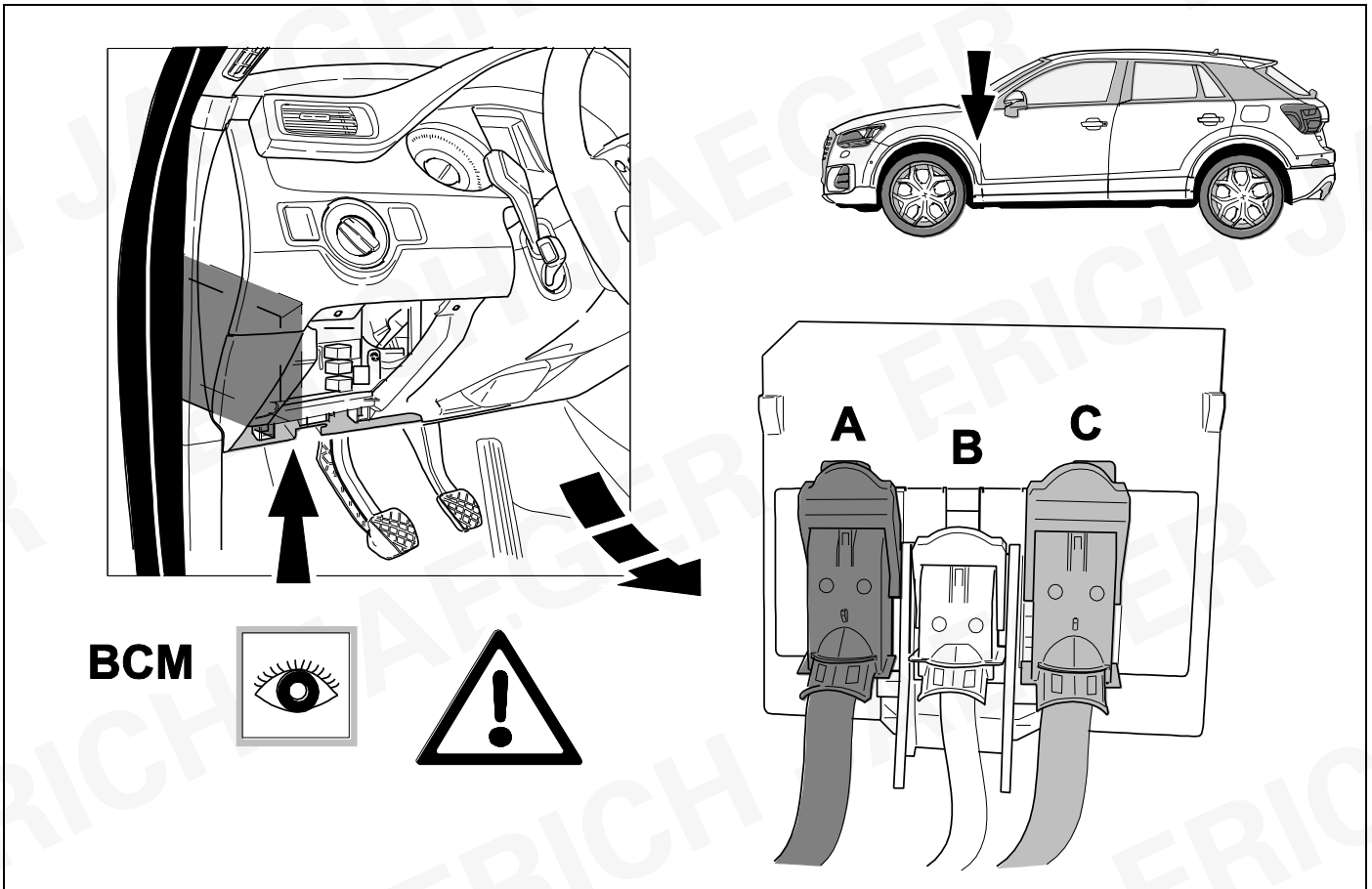

25



9

OPTION 2

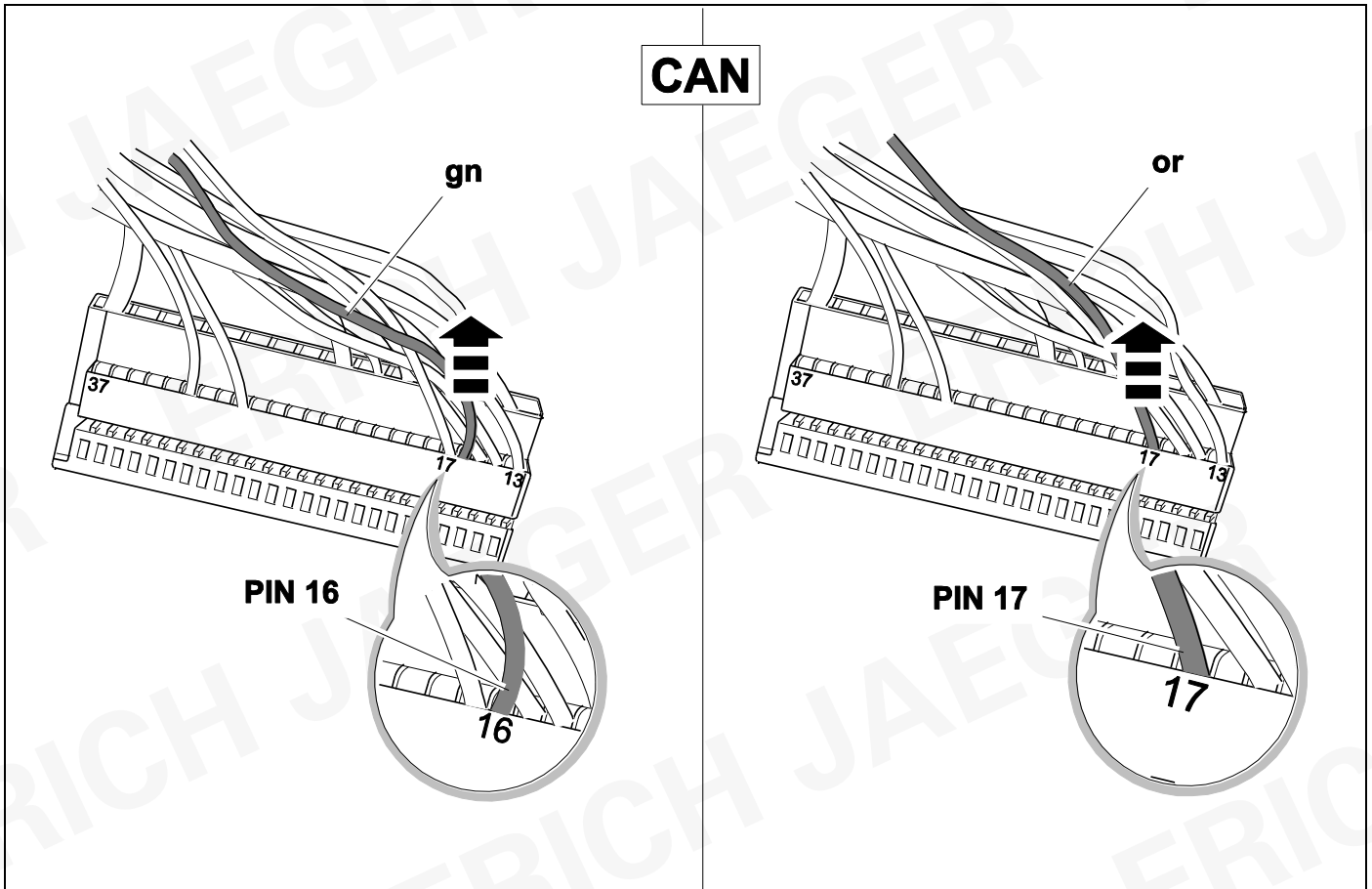

26



9

OPTION 2

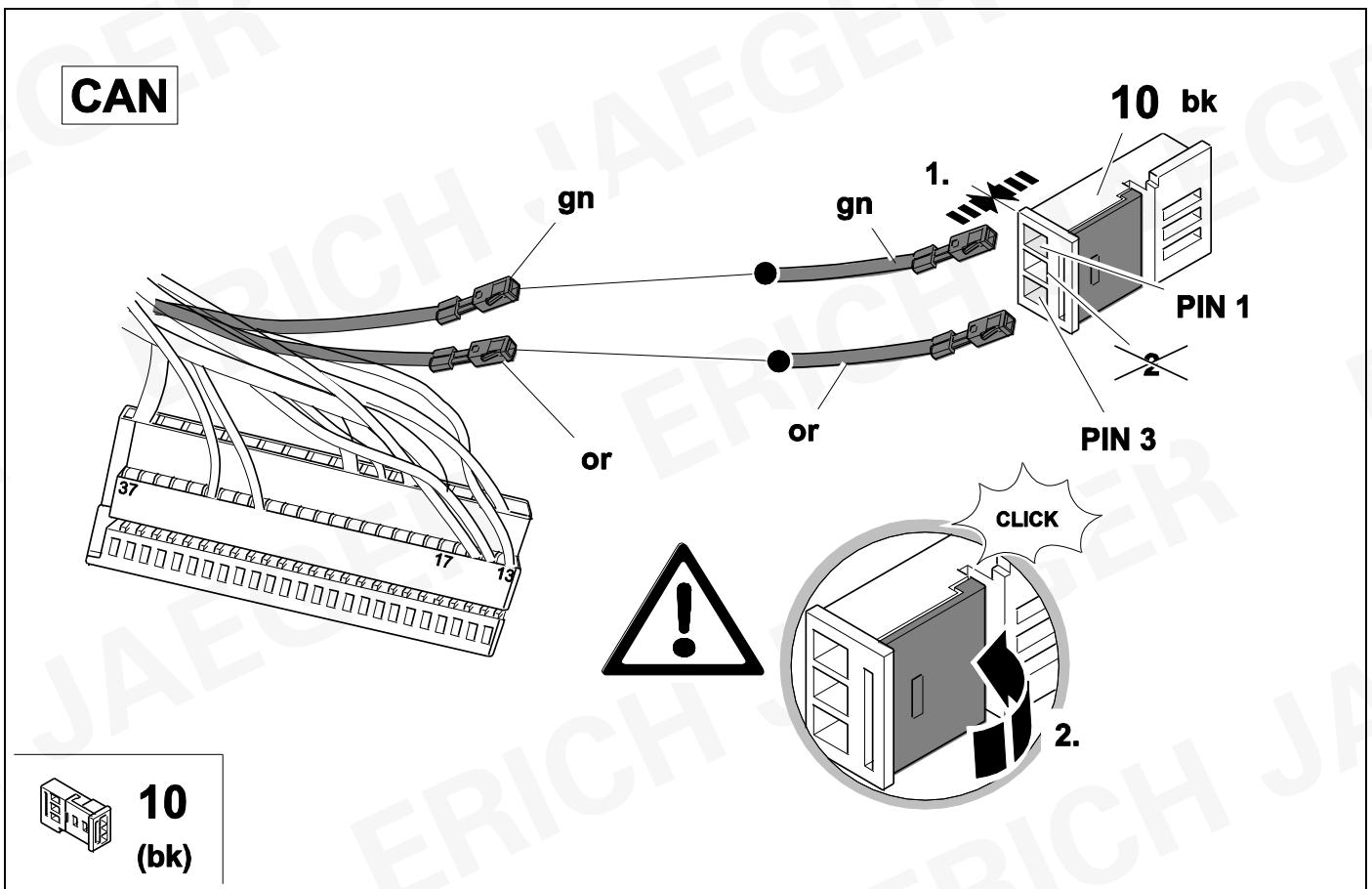



CAN

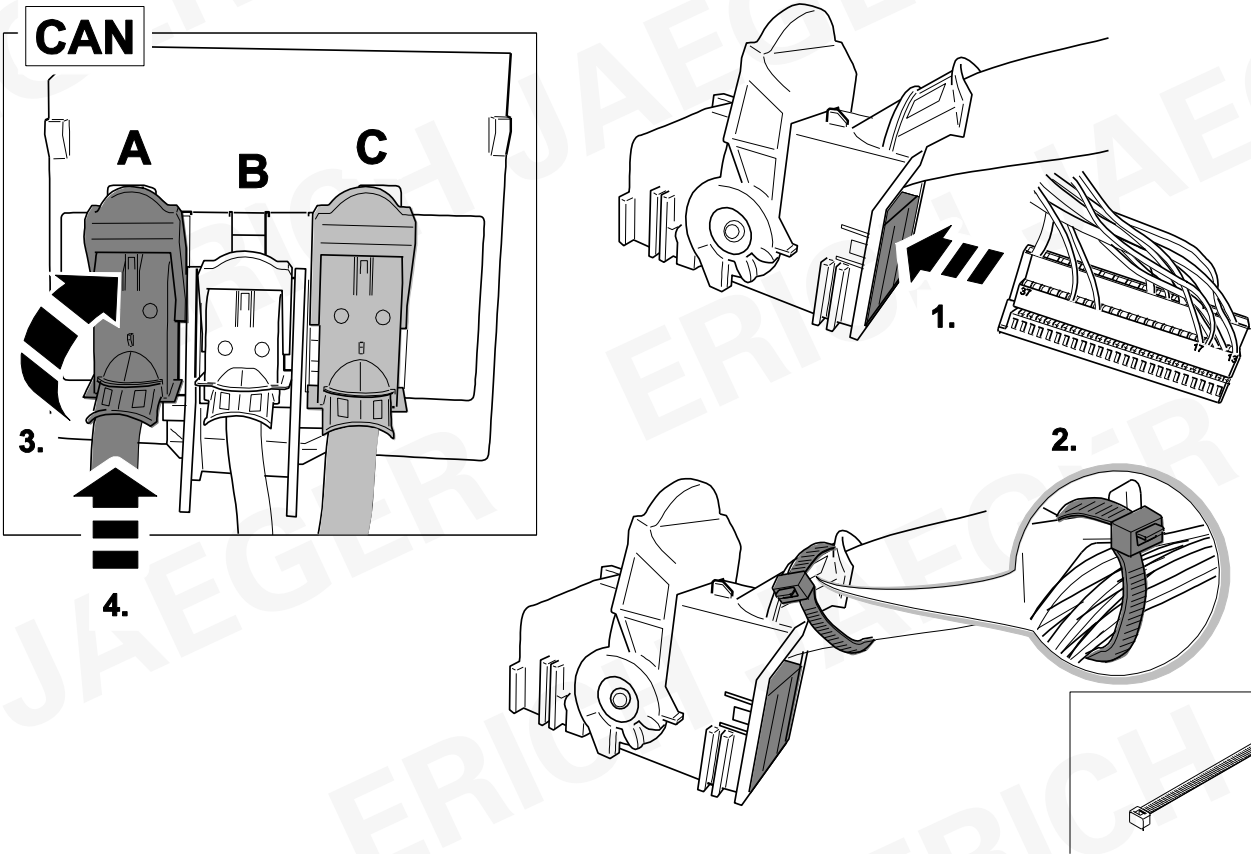
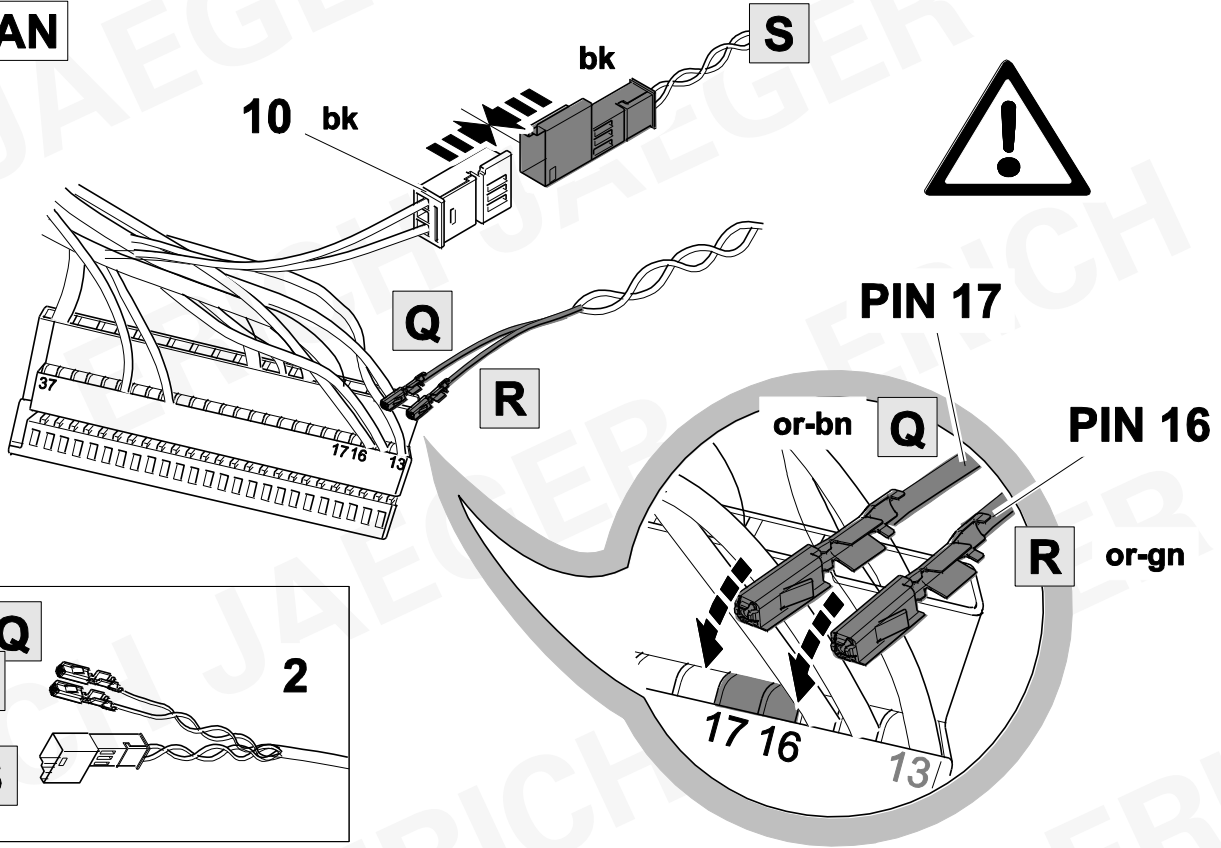

29



9

OPTION 2

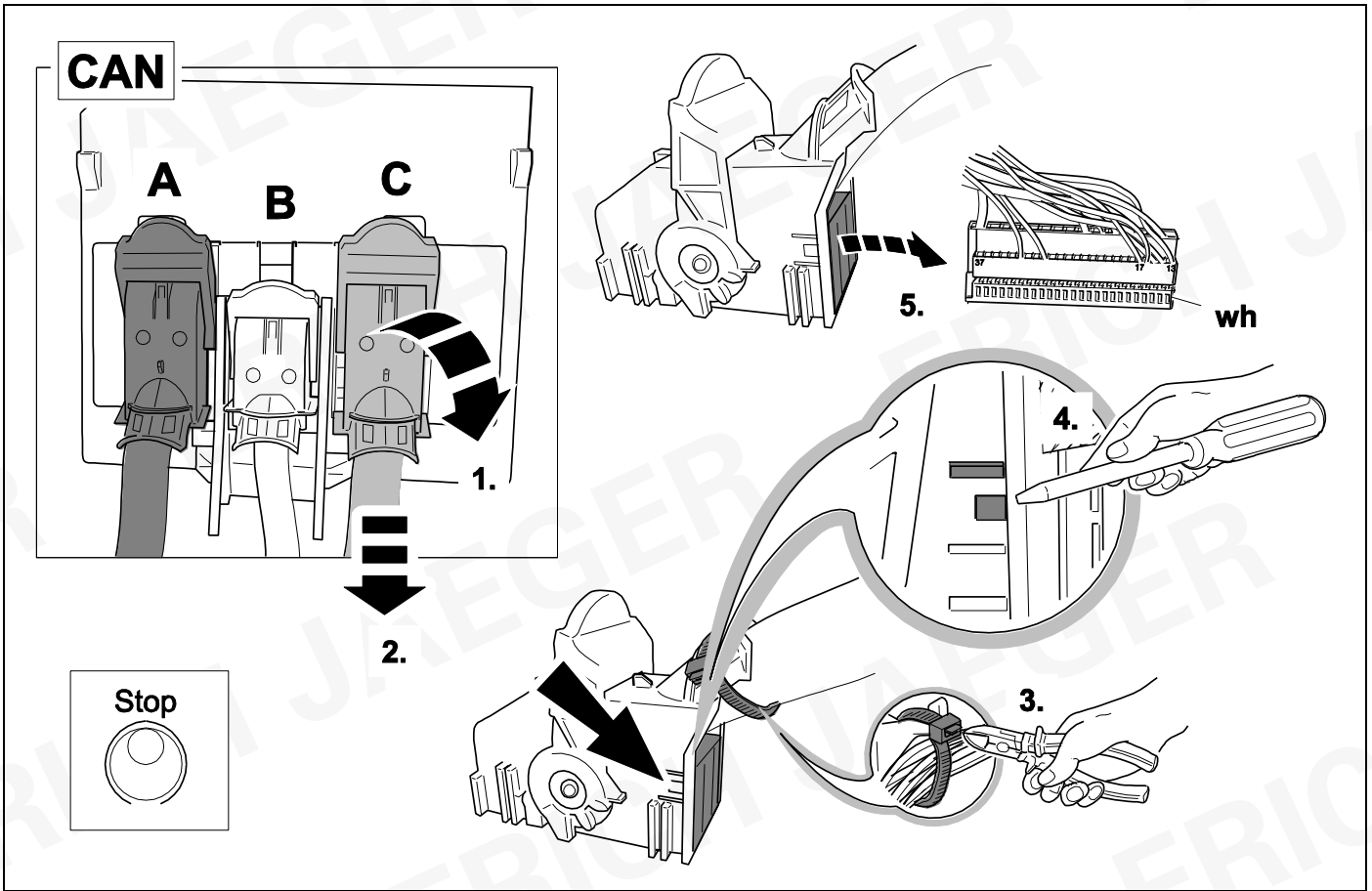

30



9

OPTION 2

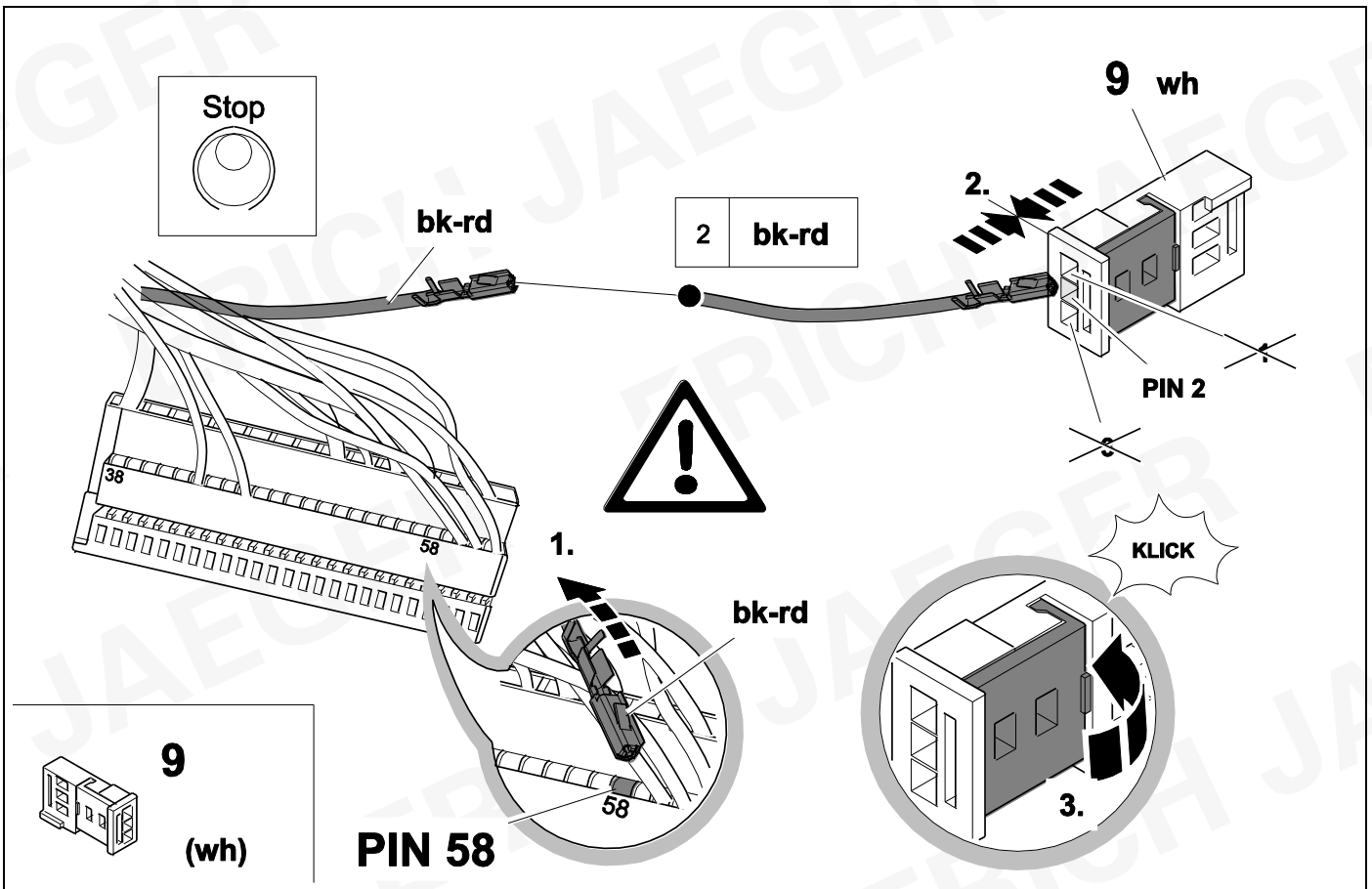

31



9

OPTION 2

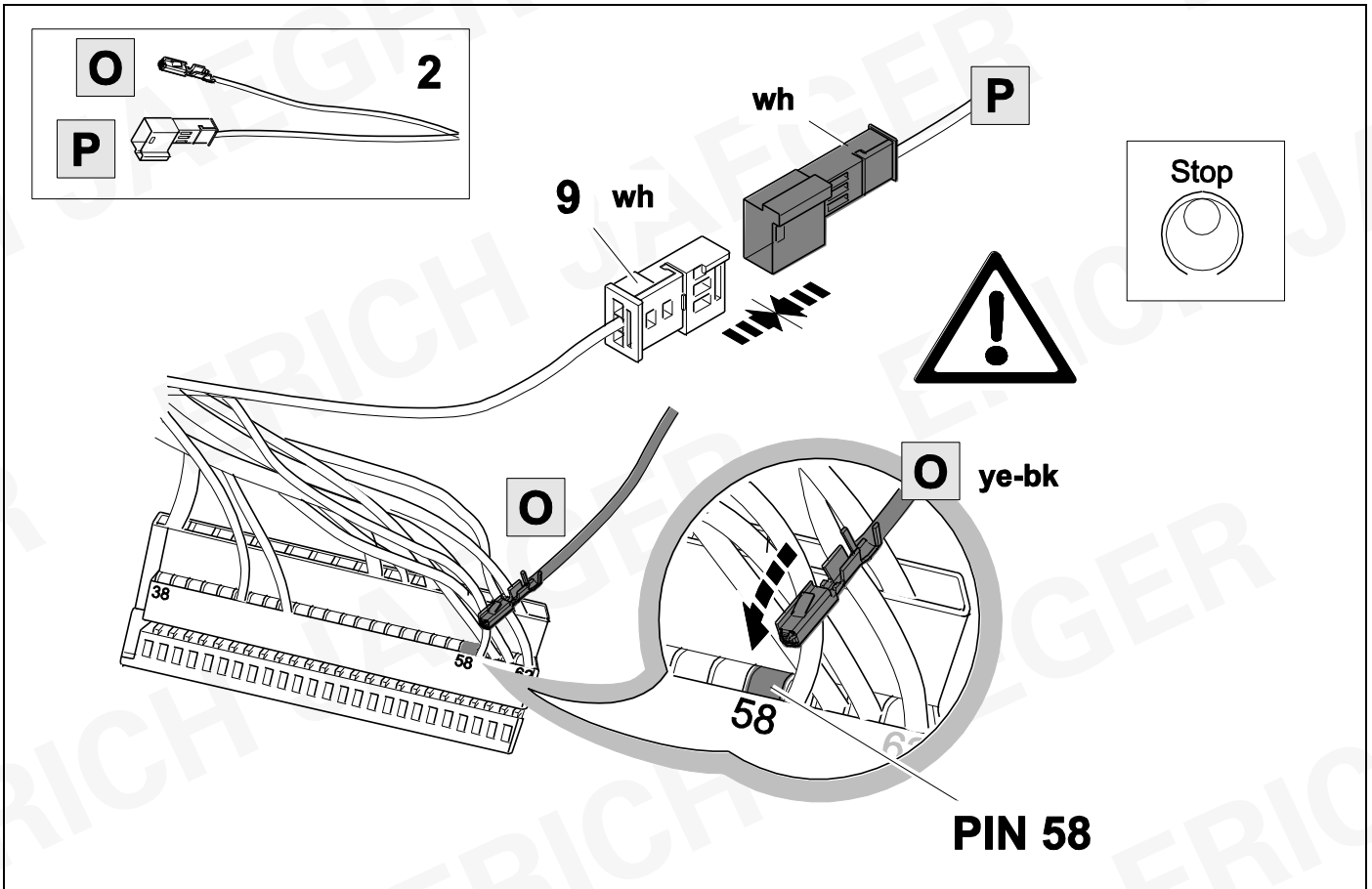

32

OPTION 2

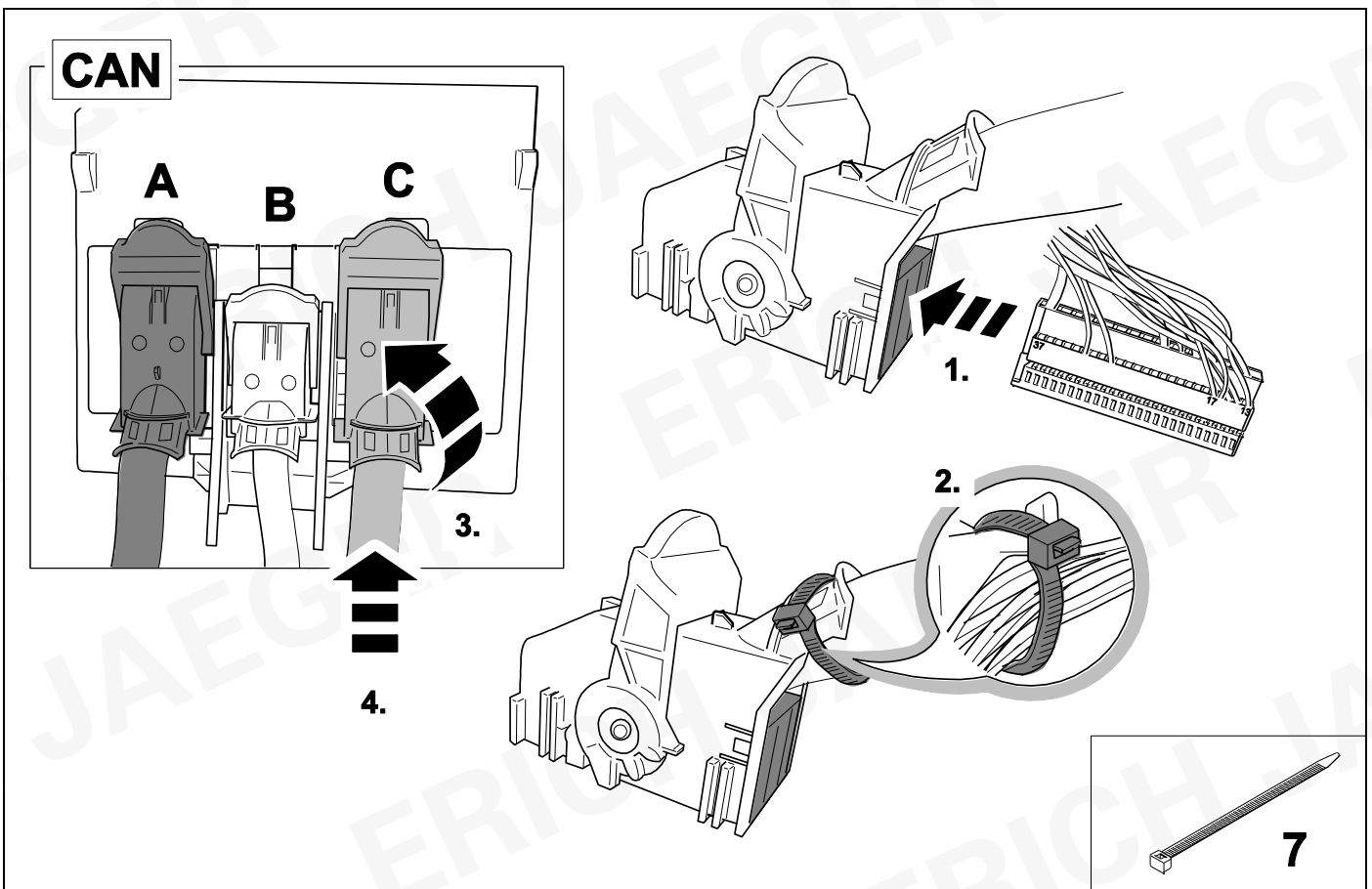

33

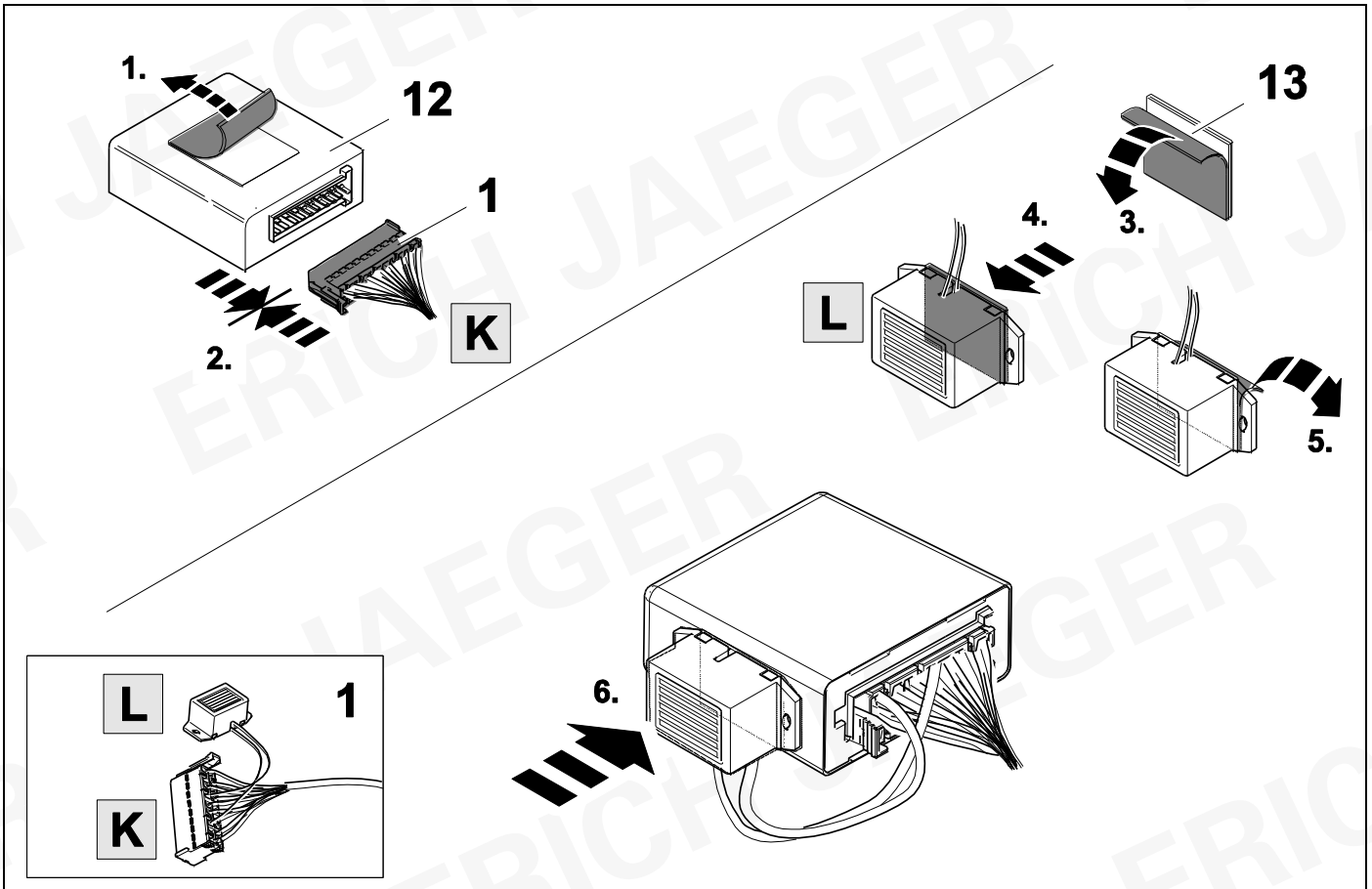

34

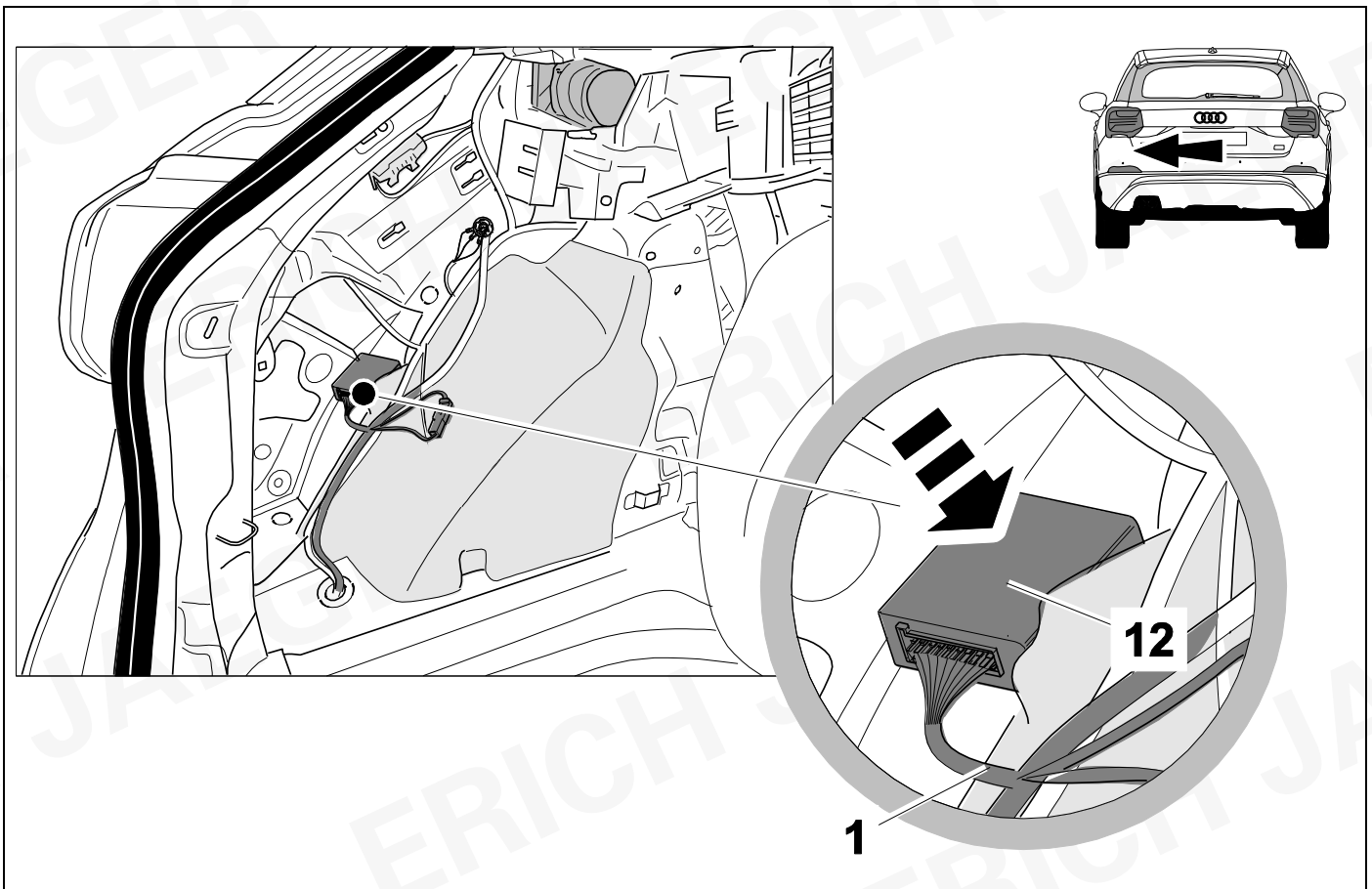



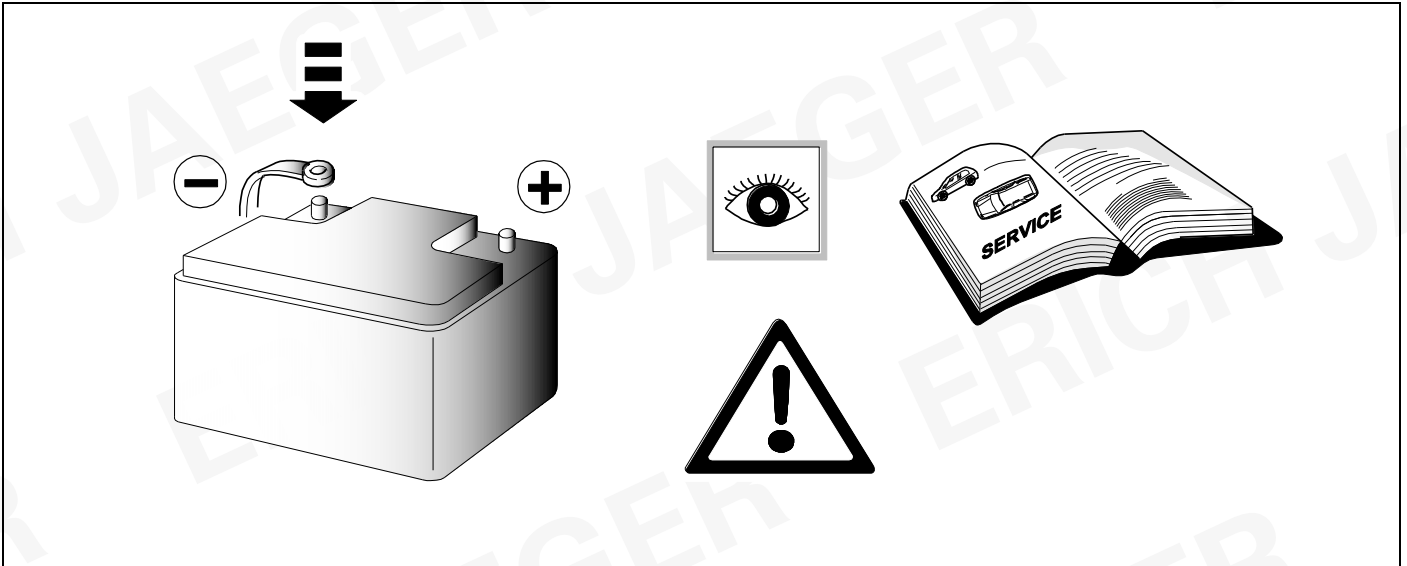

35

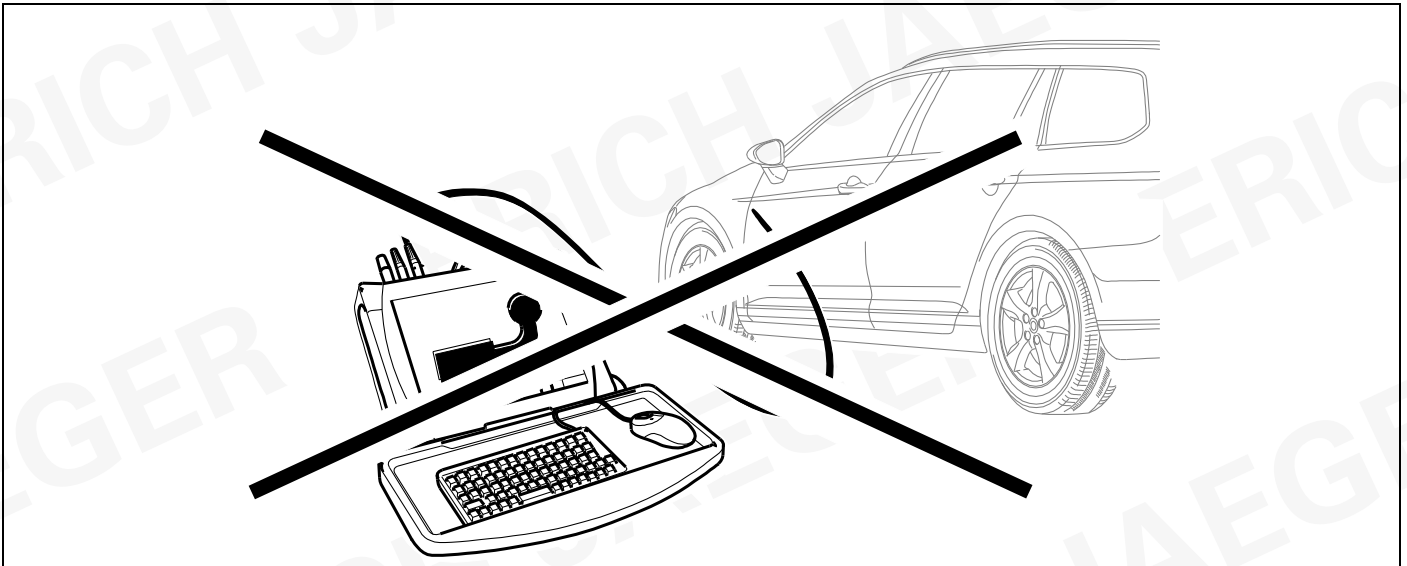

36

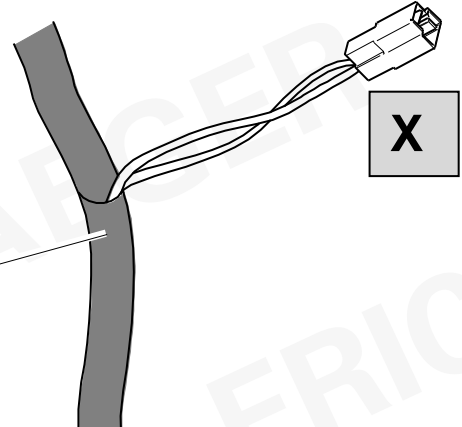
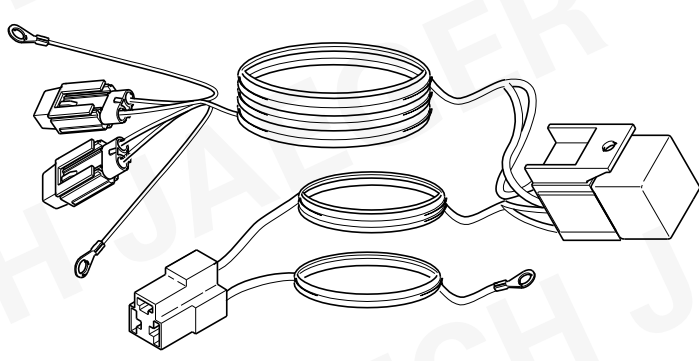

37 OPTIONAL

		ERICH JAEGER Artikelnummer: ERICH JAEGER part number:	<b>721074</b>
 <p>1</p>			

### 38 CHECK

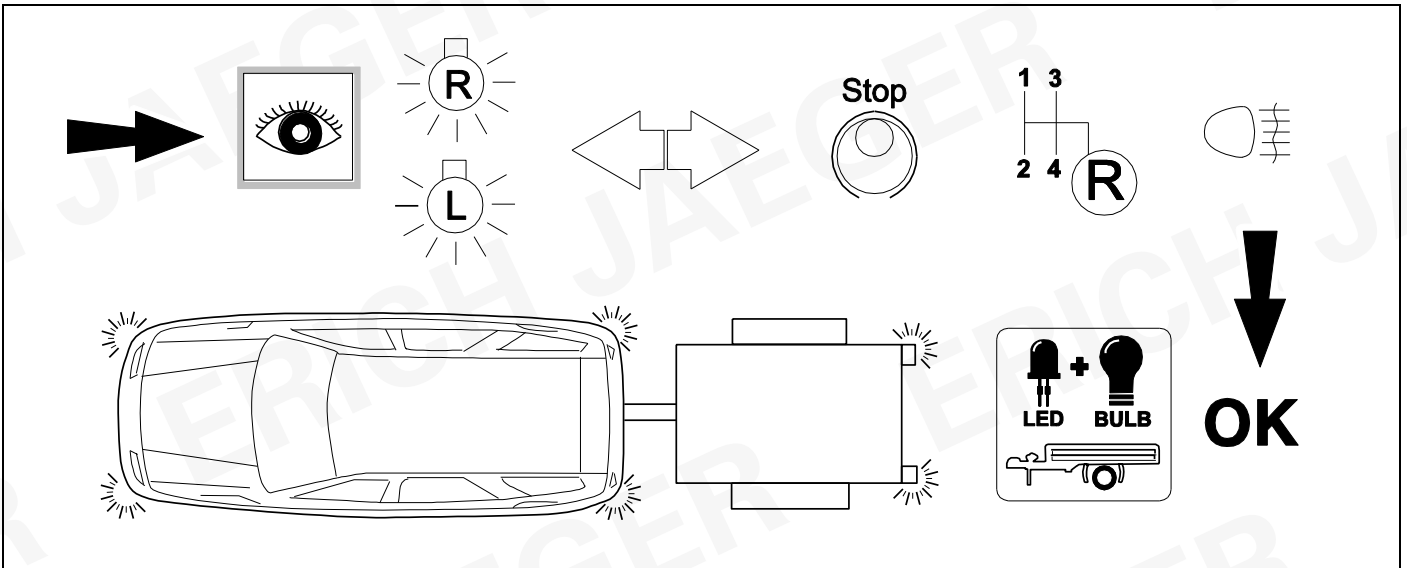

### 39 CHECK

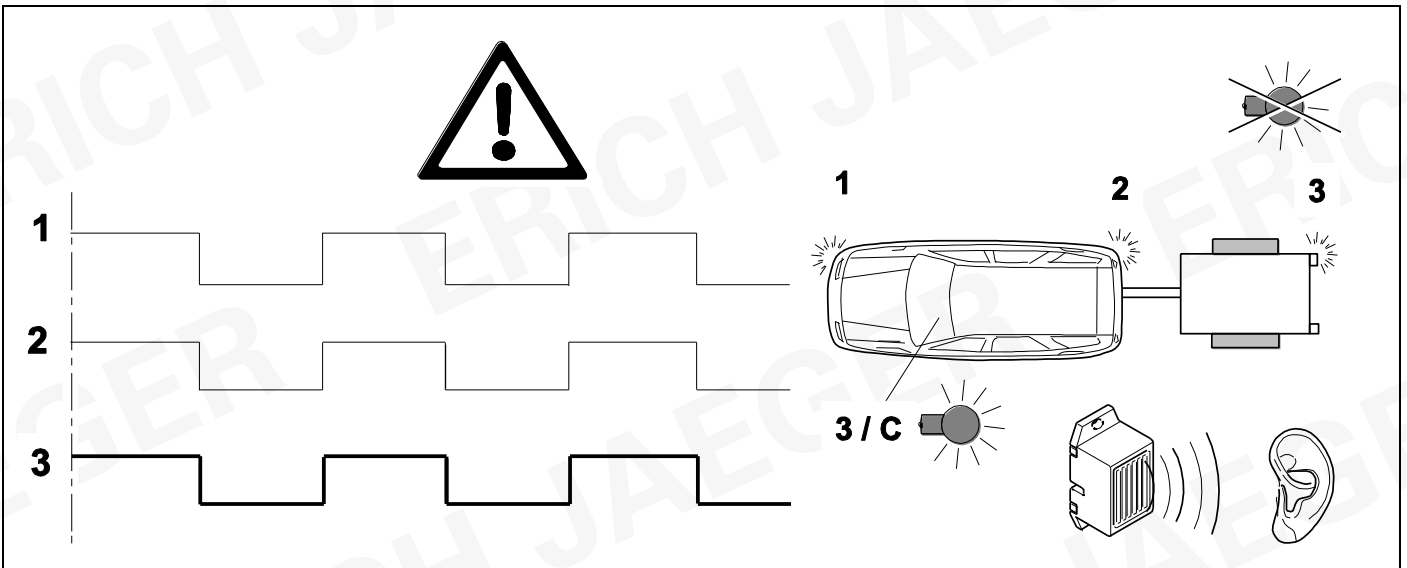

### 40 INFORMATION



21

+

22

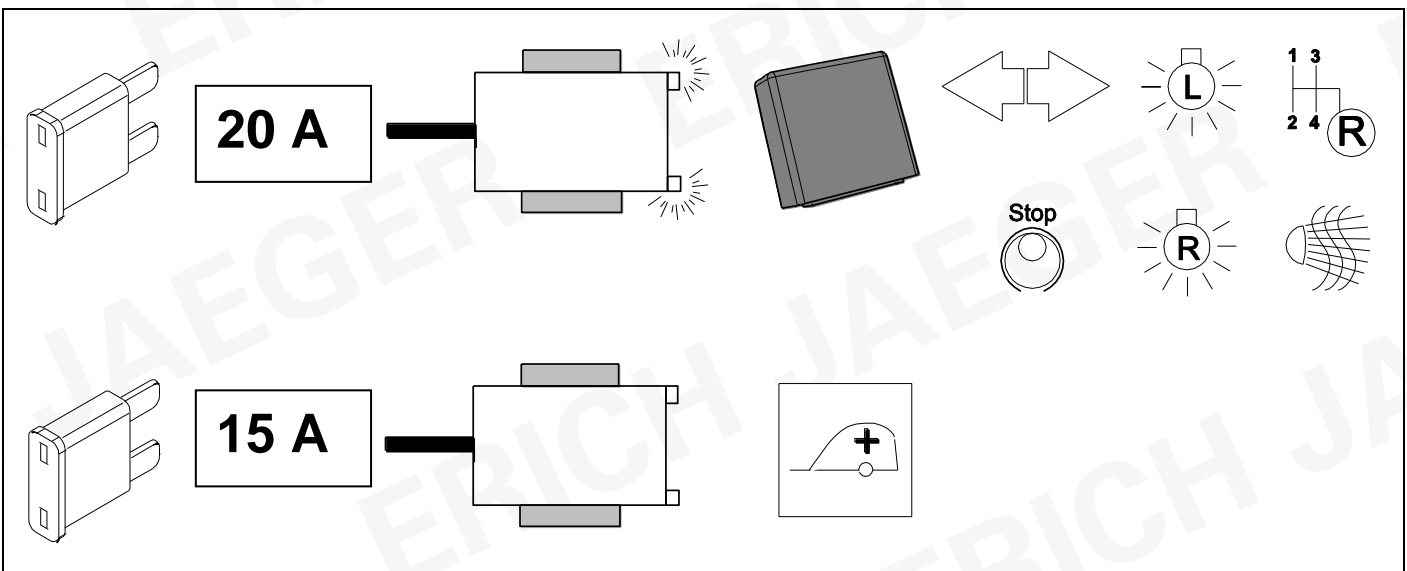

41

## OPTION vehicle coding



44



47

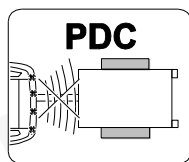

PDC

TSP  
Trailer  
Stability  
Program

P  
Trailer  
Assistent



**! Achtung !**

Diese Kodierung kann eventuell nach einem Besuch bei einer autorisierten Werkstatt verloren gehen!

**! Attention !**

These codings may be lost after visiting an authorized workshop!

42

## OPTION vehicle coding

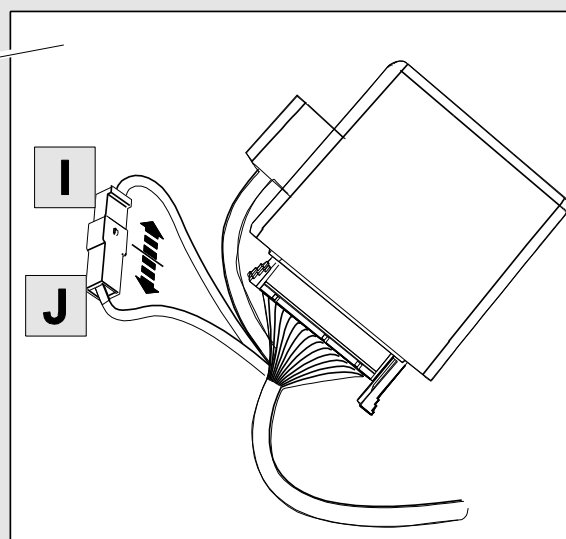
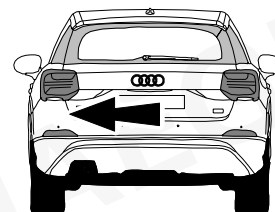
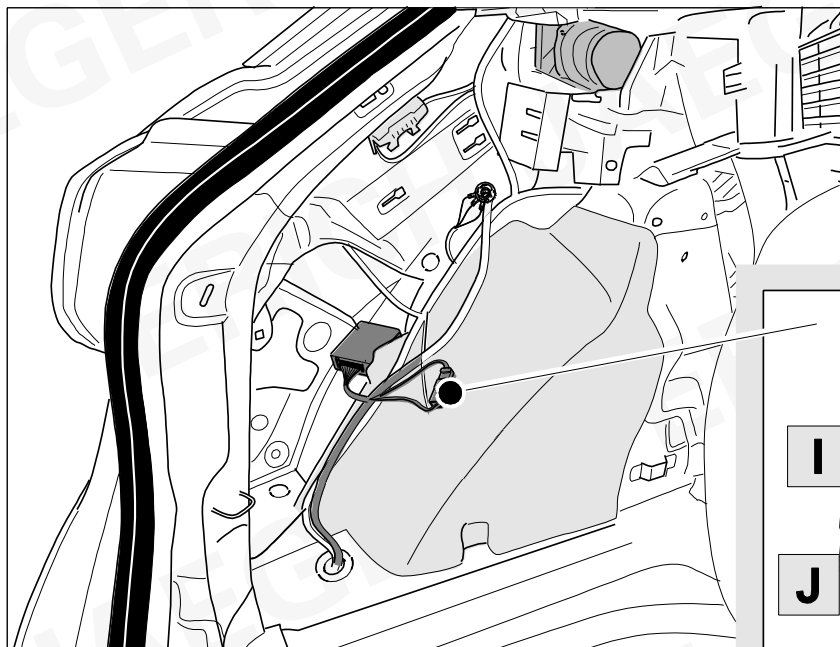

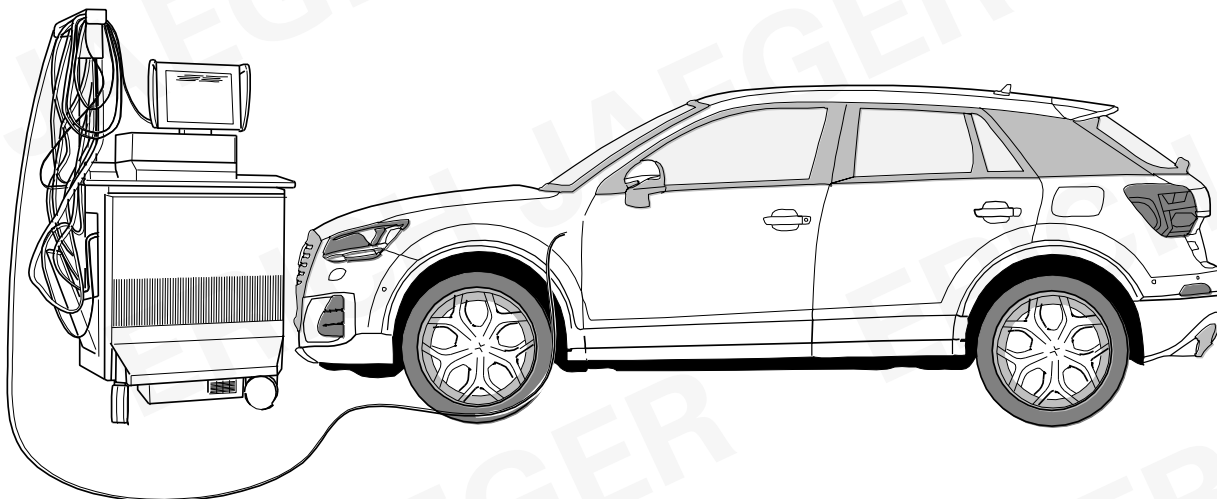
**D****Codierung bitte wie folgt durchführen:**

- Alternative Diagnosedienstleister bzw. Diagnosemethoden (lokal / offline) :
  - ODIS / VCDS
  - Hella Gutmann ( Seite 26 )
  - Autologic
  - Bosch / KTS
  - SP Diagnostic
  - SUN
  - Westfalia Auto Code
  - etc. pp.

**GB****Please effect coding as follows:**

- Alternative Diagnosis Services or diagnostic methods (local / offline) :
  - ODIS / VCDS
  - Hella Gutmann ( page 26 )
  - Autologic
  - Bosch / KTS
  - SP Diagnostic
  - SUN
  - Westfalia Auto Code
  - etc. pp.

**F****Veillez suivre le codage suivant:**

- Diagnostic services alternatives ou les méthodes de diagnostic (local/hors ligne) :
  - ODIS / VCDS
  - Hella Gutmann ( page 26 )
  - Autologic
  - Bosch / KTS
  - SP Diagnostic
  - SUN
  - Westfalia Auto Code
  - etc. pp.

**I****Favore codifica effettuate come segue:**

- -Alternativa Diagnosi Servizio o metodi diagnostici (locale/offline) :
  - ODIS / VCDS
  - Hella Gutmann ( pagina 26 )
  - Autologic
  - Bosch / KTS
  - SP Diagnostic
  - SUN
  - Westfalia Auto Code
  - etc. pp.

**E****Por favor de codificación lleva a cabo como sigue:**

- Servicio de Diagnóstico alternativa o métodos de diagnóstico (locales/fuera de linea) :
  - ODIS / VCDS
  - Hella Gutmann ( pagina 26 )
  - Autologic
  - Bosch / KTS
  - SP Diagnostic
  - SUN
  - Westfalia Auto Code
  - etc. pp.

**NL****Gelieve codering ais volgt ultgevoerd:**

- Alternatief Diagnose Dienst of diagnostische methoden (lokale/offline) :
  - ODIS / VCDS
  - Hella Gutmann ( page 26 )
  - Autologic
  - Bosch / KTS
  - SP Diagnostic
  - SUN
  - Westfalia Auto Code
  - etc. pp.

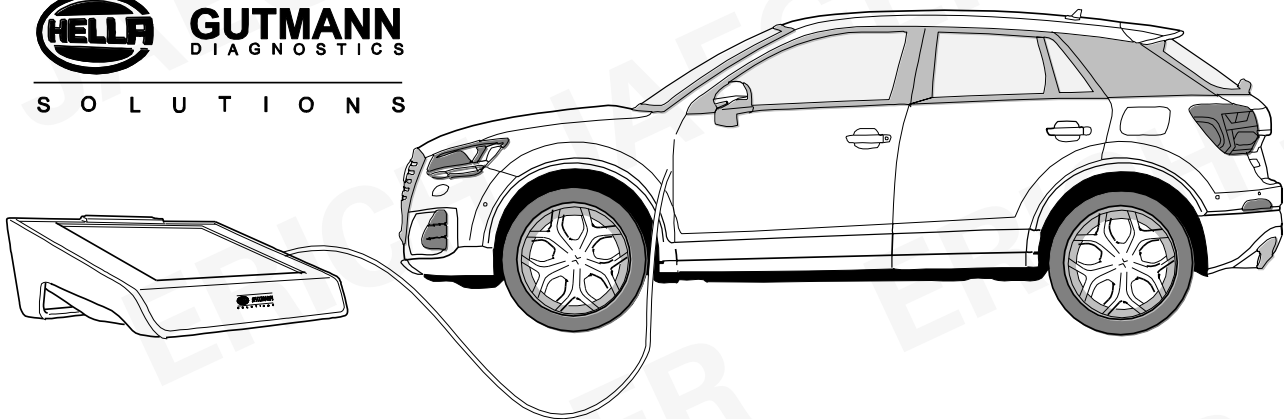

(D)	(GB)	(F)
<p><b>Die Aktivierung der Anhängerfunktionen muss wie folgt durchgeführt werden:</b></p> <ol style="list-style-type: none"> <li>1. Fahrzeugauswahl</li> <li>2. Zu Diagnose – Codierung wechseln</li> <li>3. Anhängerkupplung de-/aktivieren</li> <li>4. Diagnose Interface Bus auswählen</li> <li>5. Anleitung folgen</li> </ol> <p><b>Fahrzeuge mit Assistenzsystemen</b></p> <ol style="list-style-type: none"> <li>6. AHK an Assistenzsysteme anpassen ausführen</li> <li>7. Anleitung folgen</li> <li>8. Diagnose</li> <li>9. Fehlerspeicher auslesen, ggf. löschen</li> <li>10. Fertig</li> </ol>	<p><b>The activation of the trailer functions must be performed:</b></p> <ol style="list-style-type: none"> <li>1. Vehicle selection</li> <li>2. switch to diagnostics - coding</li> <li>3. Deactive/aktive trailer coupling</li> <li>4. Select diagnostic interface Bus</li> <li>5. Follow instructions</li> </ol> <p><b>Vehicle with assistance systems</b></p> <ol style="list-style-type: none"> <li>6. perform adaptation of trailer coupling on assistance systems</li> <li>7. Follow instructions</li> <li>8. Diagnostics</li> <li>9. Read out error memory, delete if necessary</li> <li>10. Done</li> </ol>	<p><b>Pour activer l'attelage, procéder de la façon suivante:</b></p> <ol style="list-style-type: none"> <li>1. Choix véhicule</li> <li>2. Aller dans le diagnostic - codage</li> <li>3. Activer/désactiver le diagnostic</li> <li>4. Sélectionner le BUS d'interface de diagnostic</li> <li>5. Suivre les instructions</li> </ol> <p><b>Véhicules avec systèmes d'aide</b></p> <ol style="list-style-type: none"> <li>6. Effectuer une adaptation d'attelage aux systèmes d'aide</li> <li>7. Suivre les instructions</li> <li>8. Diagnostic</li> <li>9. Lire la mémoire de défaut et effacer les codes d'erreur éventuellement mémorisés</li> <li>10. Terminé</li> </ol>
(I)	(E)	(NL)
<p><b>Per attivare le funzioni del rimorchio, procedere nel modo seguente:</b></p> <ol style="list-style-type: none"> <li>1. Scelta vettura</li> <li>2. Passare alla Diagnosi - Codifica</li> <li>3. Attivare / disattivare il gancio di traino</li> <li>4. Selezionare il interfaccia di diagnosi</li> <li>5. Seguire le istruzioni</li> </ol> <p><b>Veicoli noc suster di assistenza</b></p> <ol style="list-style-type: none"> <li>6. adattare i suster installati</li> <li>7. Seguire le istruzioni</li> <li>8. Diagnosi</li> <li>9. Leggere la memoria guasti e cancellare, se necessario</li> <li>10. Fertig</li> </ol>	<p><b>La activación de las funciones de remolque debe la siguiente manera:</b></p> <ol style="list-style-type: none"> <li>1. Selección de vehículo</li> <li>2. Cambiar a diagnosis - Codificación</li> <li>3. Desactivar/ activar acoplamiento para remolque</li> <li>4. Selecciona diagnosis Interface Bus</li> <li>5. Seguir las instrucciones</li> </ol> <p><b>En vehículos noc sistemas de asistencia</b></p> <ol style="list-style-type: none"> <li>6. Ejecutar adaptación de acoplamiento para remolque a suster de asistencia</li> <li>7. Seguir las instrucciones</li> <li>8. Diagnosi</li> <li>9. Leer memoria de averias y borrarla si es necesario</li> <li>10. Listo</li> </ol>	<p><b>De activering van de aanhangfuncties moet als volgt worden uitgevoerd:</b></p> <ol style="list-style-type: none"> <li>1. Voertuigselectie</li> <li>2. Ga naar Diagnose - Codering</li> <li>3. Aanhangwagenkoppeling deactiveren/activeren</li> <li>4. Diagnose interface bus selecteren</li> <li>5. Volg instructie op</li> </ol> <p><b>Bij voertuigen met assistentiesystemen</b></p> <ol style="list-style-type: none"> <li>6. „Aanhangwagenkoppeling aanpassen aan assistietiesystem“ uitvoeren</li> <li>7. Volg instructie op</li> <li>8. Diagnose</li> <li>9. Foutcodegeheugen uitlezen en indien nodig wissen</li> <li>10. Gereed</li> </ol>

# 45 CHECK

# OPTION vehicle coding

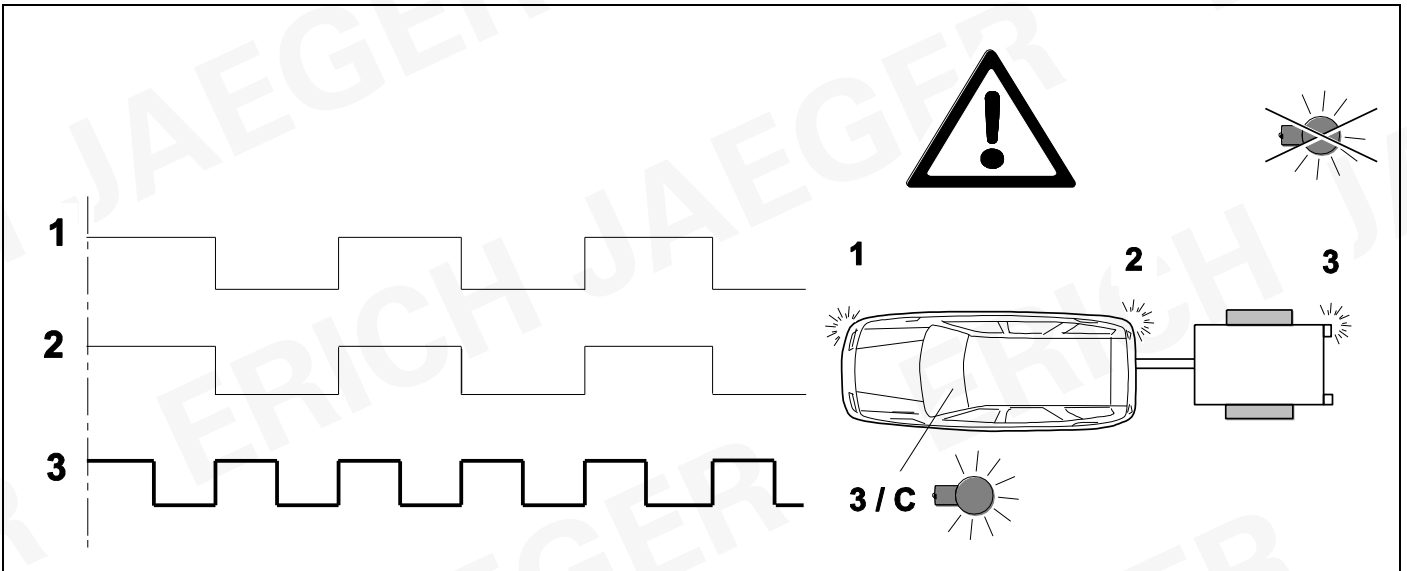

# 46

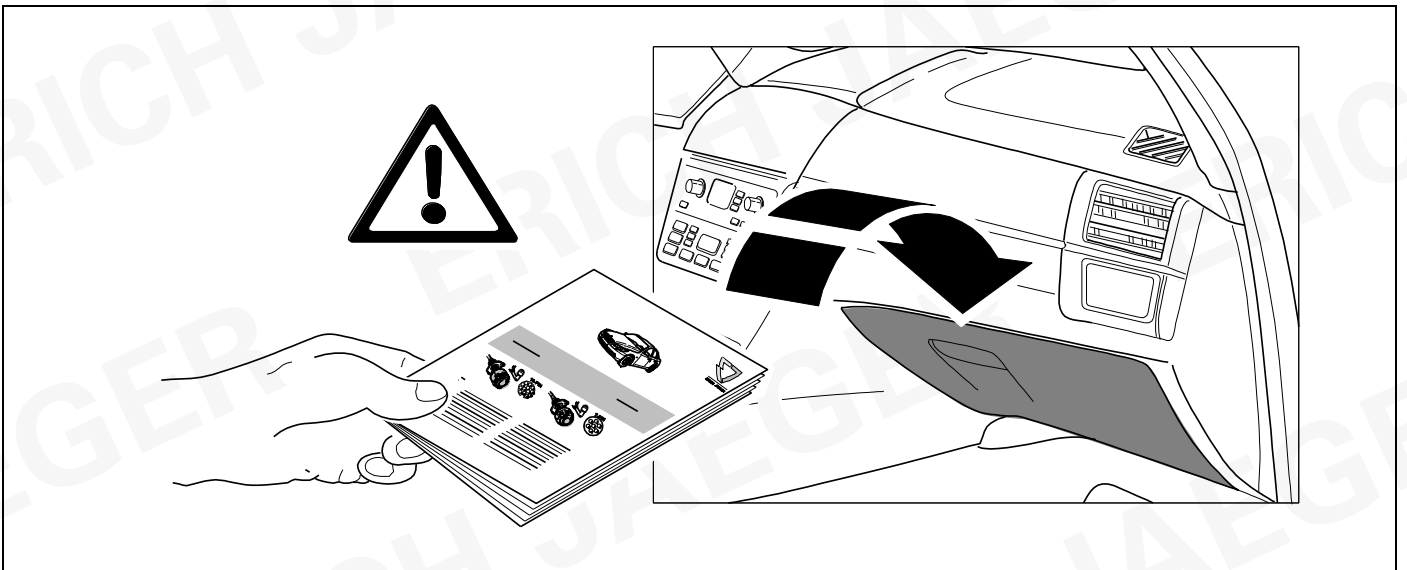

# 47

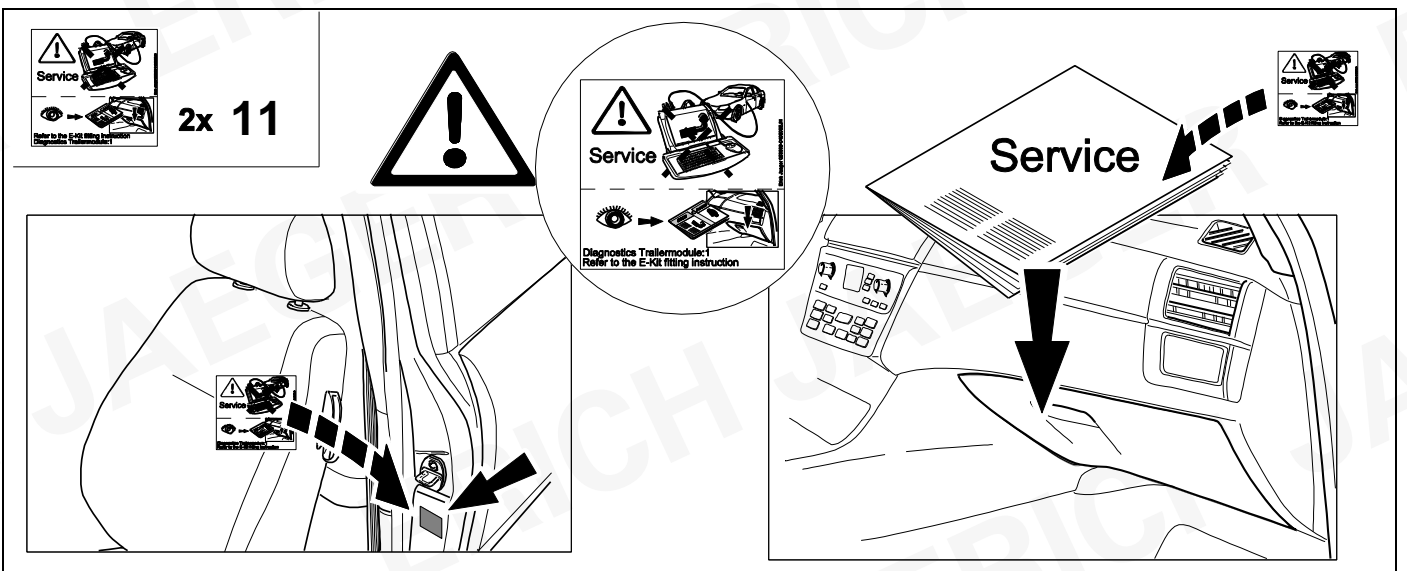

ERICH JAEGER

<b>D</b>	Änderungen bezüglich Konstruktion, Ausstattung Farbe sowie Irrtum vorbehalten. Angaben und Abbildungen unverbindlich	<b>PL</b>	Zastrzega się prawo do zmian dot. konstrukcji, wykończenia, kolorystyki oraz pomyłek. Dane i ilustracje niewiążące.
<b>GB</b>	Subject to change in terms of construction, equipment and colour, and may contain errors. The information and illustrations are non-binding.	<b>TR</b>	Tasarım, donanım ve renk bakımından değişiklik yapma hakkı ve hata ve eksiklik mahfuzdur. Veriler ve resimler bağlayıcı değildir.
<b>F</b>	Sous réserve de modifications de la construction, de équipement, de la couleur et sous réserve d'erreurs. Les indications et les illustrations sont sans engagement.	<b>H</b>	A szerkezet, a kivitel és a szín változtatása, valamint a változások joga fenntartva. Az adatok és az ábrák nem kötelező érvényűek.
<b>NL</b>	Wijzigingen met betrekking tot constructie, uitvoering en kleur evenals vergissingen voorbehouden. Gegevens en afbeeldingen niet bindend.	<b>HR</b>	Pravo promjena u svezi konstrukcije, opreme, boje kao i zabune oridžavamo. Podaci i ilustracije su neobavezne.
<b>DK</b>	Ændringer med hensyn til konstruktion, udstyr, farver samt fejl forbeholdes. Oplysninger og illustrationer er uforpligtende.	<b>BUL</b>	Запазени права по отношение на конструкцията, обзавеждането, цвета и грешки. Данните и изображенията не са обвързващи.
<b>N</b>	Ændringer angående konstruksjon, utstyr, farge og feiltagelse forbeholdes. Oplysninger og illustrasjoner uforbindtlig.	<b>RO</b>	Ne rezervăm dreptul unor modificări ale construcției, dotării, culorii și dreptul la erori Datele indicate și imaginile sunt orientative.
<b>S</b>	Med reservation för ändringar vad det gäller konstruktion, utrustning, färg samt för misstag. Uppgifterna och bilderna är inte bindande.	<b>RU</b>	Права на внесение изменений относительно конструкции, оснащения, окраски, а также на ошибки сохраняются. Данные и иллюстрации имеют примерный характер.
<b>FIN</b>	Pidätämme oikeuden rakennetta, varustusta, väriä koskeviin sekä erehdyksestä johtuviin muutoksiin. Tiedot ja kuvat eivät ole sitovia.	<b>LT</b>	Pasiliekaama konstrukcijos, įrangos bei reikmenų, spalvos pakeitimų ir klaidų teisė. Duomenys ir iliustracijos neįpareigojantys.
<b>I</b>	Con riserva di modifiche relative a progettazione, dotazione, colore ed errori. Le indicazioni e figure sono fornite senza impegno.	<b>LV</b>	Tiek paturētas tiesības uz konstrukcijas, iekārtu, krāsu izmaiņām, kā arī kļūdīšanās. Dati un attēli bez saistībām.
<b>E</b>	Reservadas las modificaciones respecto a diseño, equipamiento, color, así como error. Indicaciones y figuras sin compromiso.	<b>EST</b>	Konstruksiooni, varustuse ja võervi osas muudatused ning eksimine lubatud. Andmed ja joonised on mittesiduvad.
<b>P</b>	Reservamos o direito de alterações relativamente ao desenho, equipamento, cor, bem como de erro. Os dados e as gravuras não implicam compromisso da nossa parte.	<b>SLO</b>	Zadržana pravica do sprememb glede konstrukcije, opreme, barve ter pomote. Podatki in slike so neobvezne.
<b>GR</b>	Διατηρώνουμε κάθε επιφύλαξη ως προς αλλαγές σε σχέση με κατασκευή, εξοπλισμό, διαρρύθμιση, χρωματισμούς και λάθη παραδρομής.	<b>SK</b>	Zmeny, ktoré sa týkajú konštrukcie, vybavenia, farby, ako aj omyly sú vyhradené. Údaje a zobrazenia sú nezáväzné.
<b>CZ</b>	Změny, týkající se konstrukce, vybavení, barvy, jakož i omyly jsou vyhrazeny. Údaje a vyobrazení jsou nezávazné.		

**ERICH JAEGER Artikelnummer:**  
**ERICH JAEGER part number:**

**311069**

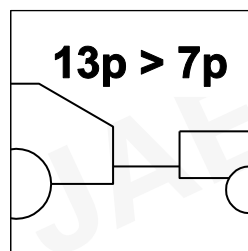
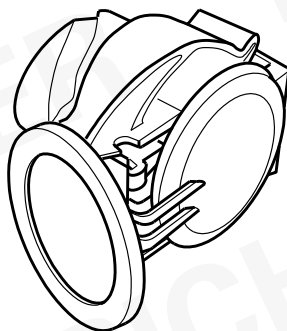



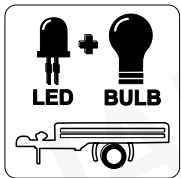

**Jaeger FLEX  
2in1**

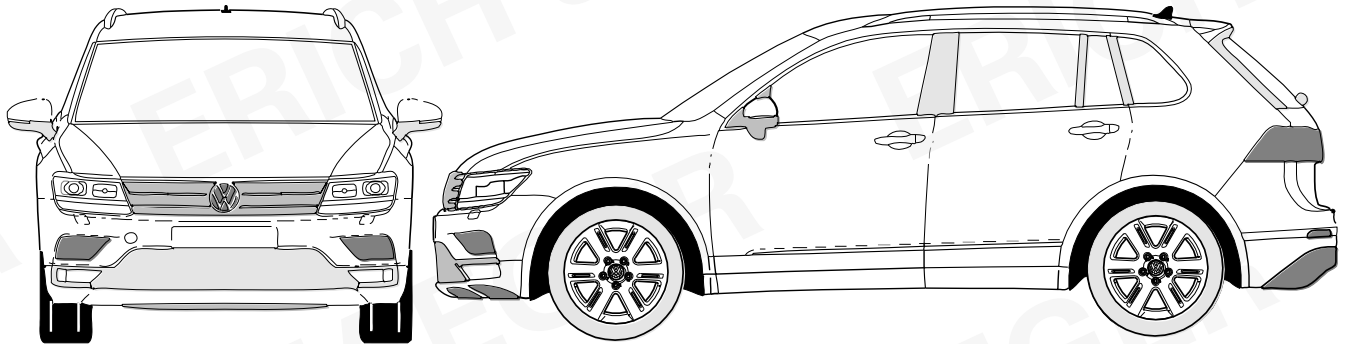

**VW Tiguan**

**05/16 >>**

**748343**

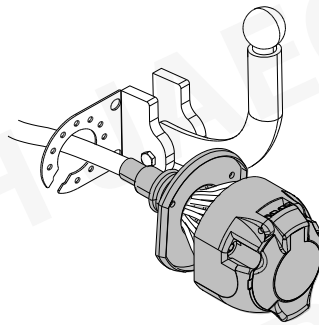

**13-PIN**

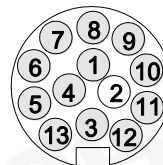

**ISO 11446**

- |  |   |
|--|---|
| <b>(D)</b> Einbauanleitung             | <b>(PL)</b> Instrukcja montażu                |
| <b>(GB)</b> Installation instructions  | <b>(TR)</b> Montaj talimatı                   |
| <b>(F)</b> Consignes de montage        | <b>(H)</b> Beépítési útmutató                 |
| <b>(NL)</b> Montagehandleiding         | <b>(HR)</b> Upute o ugradnji                  |
| <b>(DK)</b> Montagevejledning          | <b>(BUL)</b> Инструкция за монтаж             |
| <b>(N)</b> Monteringsinstruksjon       | <b>(RO)</b> Instrucțiuni de montaj            |
| <b>(S)</b> Installationsanvisning      | <b>(RU)</b> Инструкция по монтажу и установке |
| <b>(FIN)</b> Asennusohje               | <b>(LT)</b> Montavimo informacija             |
| <b>(I)</b> Istruzioni per il montaggio | <b>(LV)</b> Iemontēšanas pamācība             |
| <b>(E)</b> Instrucciones de montaje    | <b>(EST)</b> Paigaldusjuhend                  |
| <b>(P)</b> Instruções de montagem      | <b>(SLO)</b> Navodilo za vgradnjo             |
| <b>(GR)</b> Οδηγίες εγκατάστασης       | <b>(SK)</b> Montážny návod                    |
| <b>(CZ)</b> Návod k montáži            |   |



# KIT

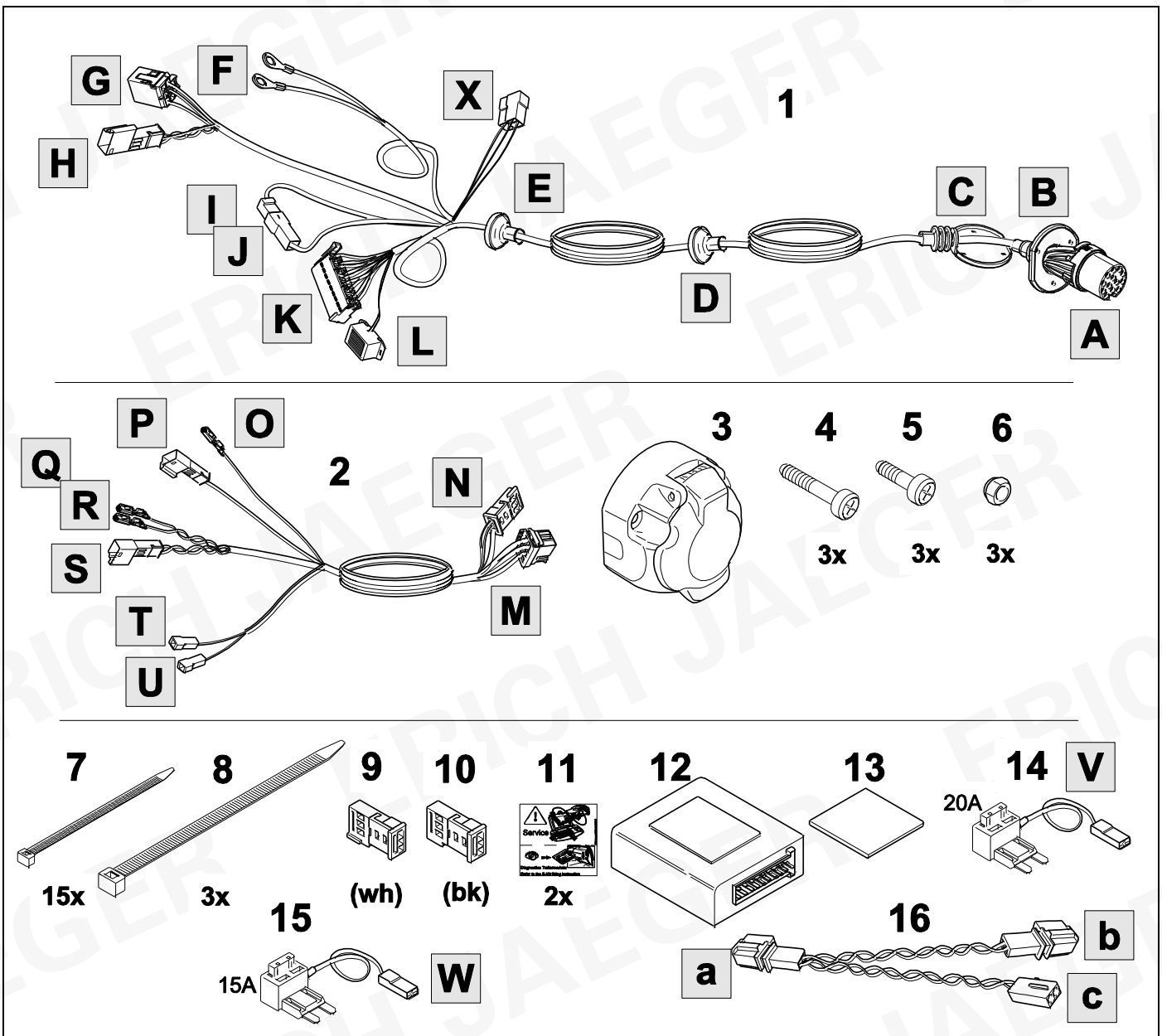

# TOOLS

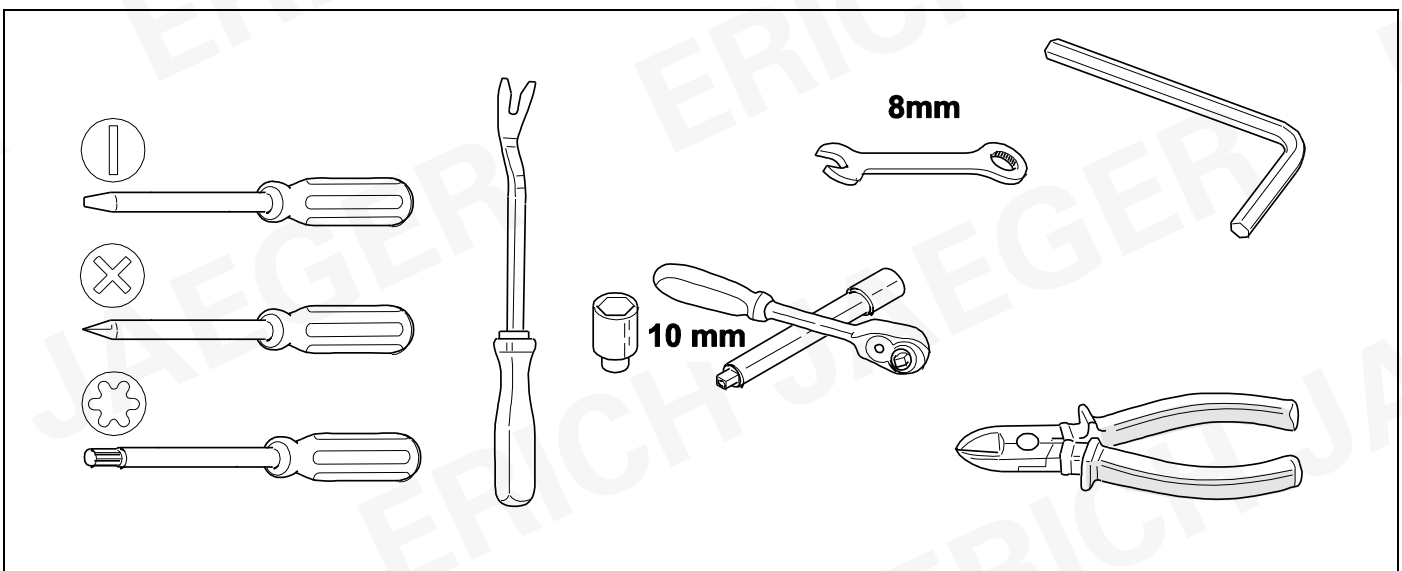

1

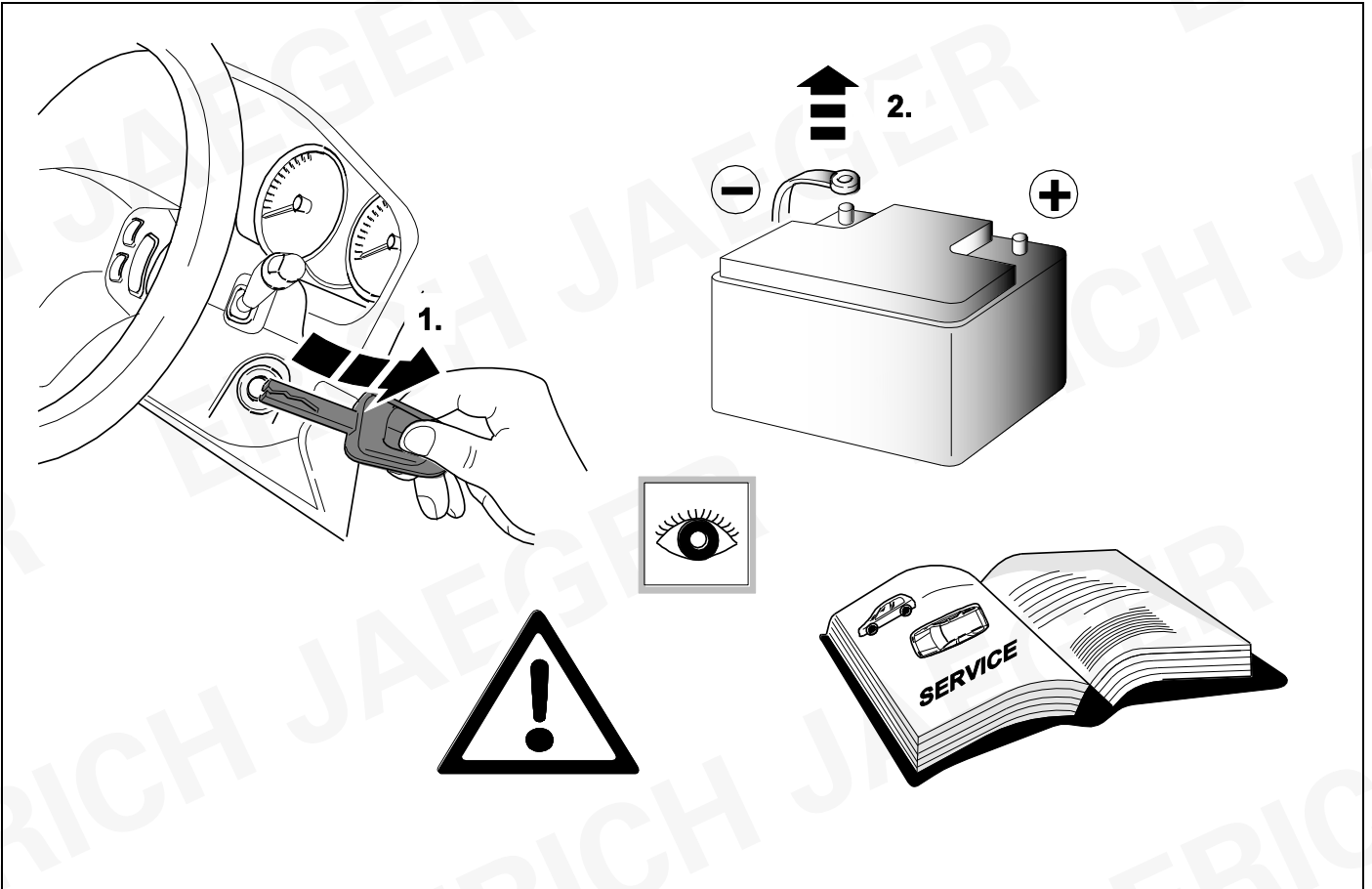

## 2 REMOVE

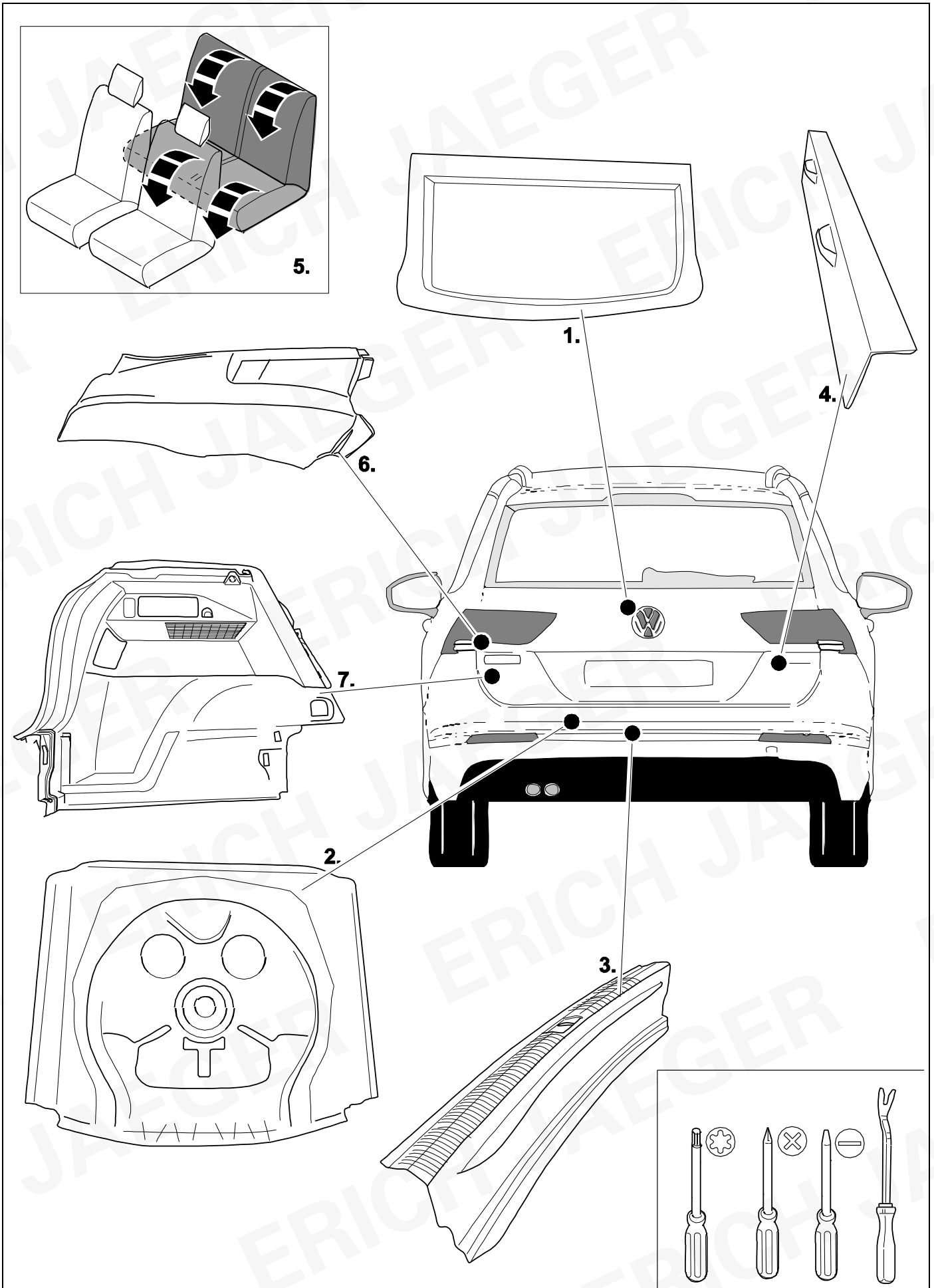

3

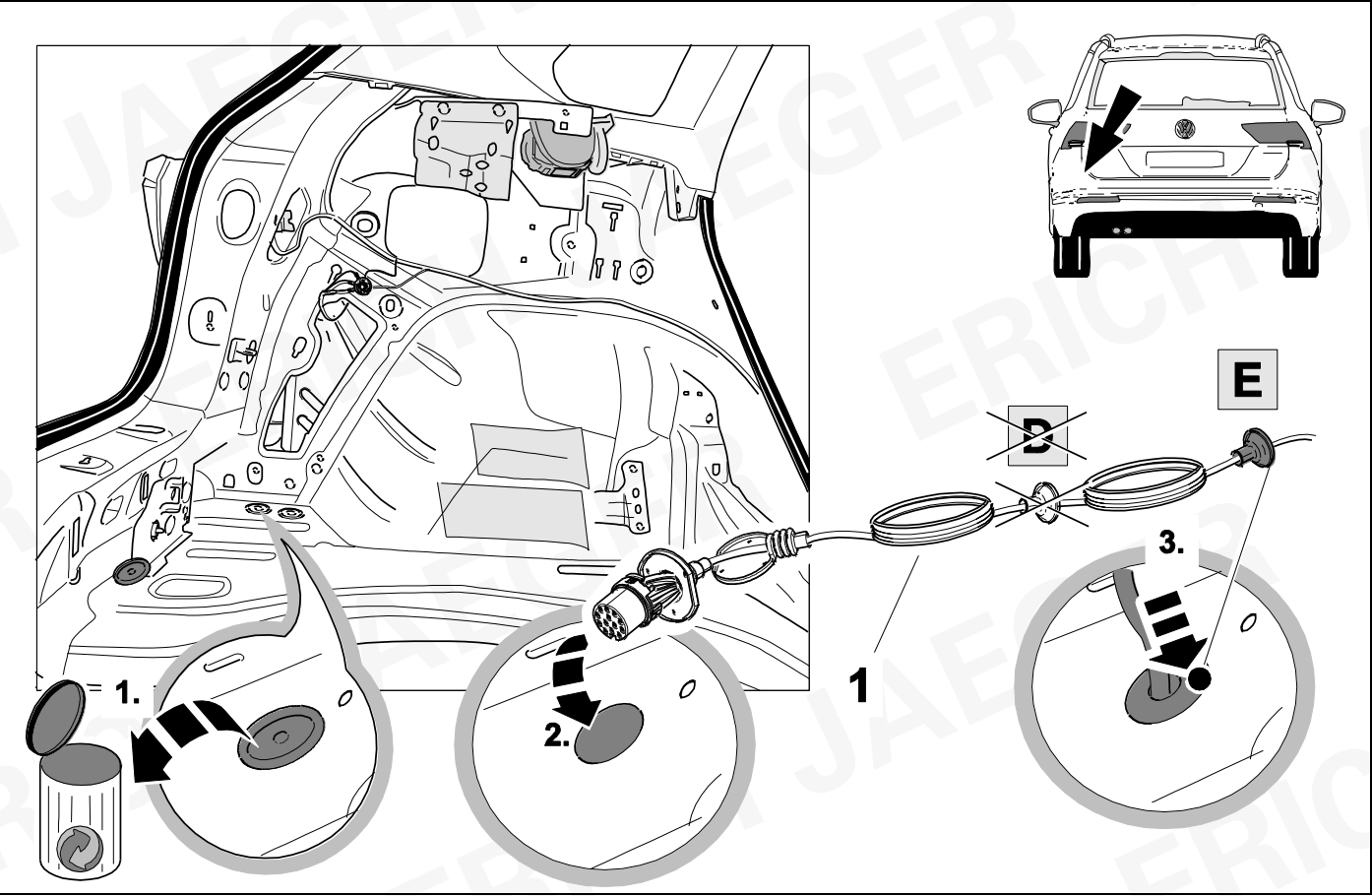

4

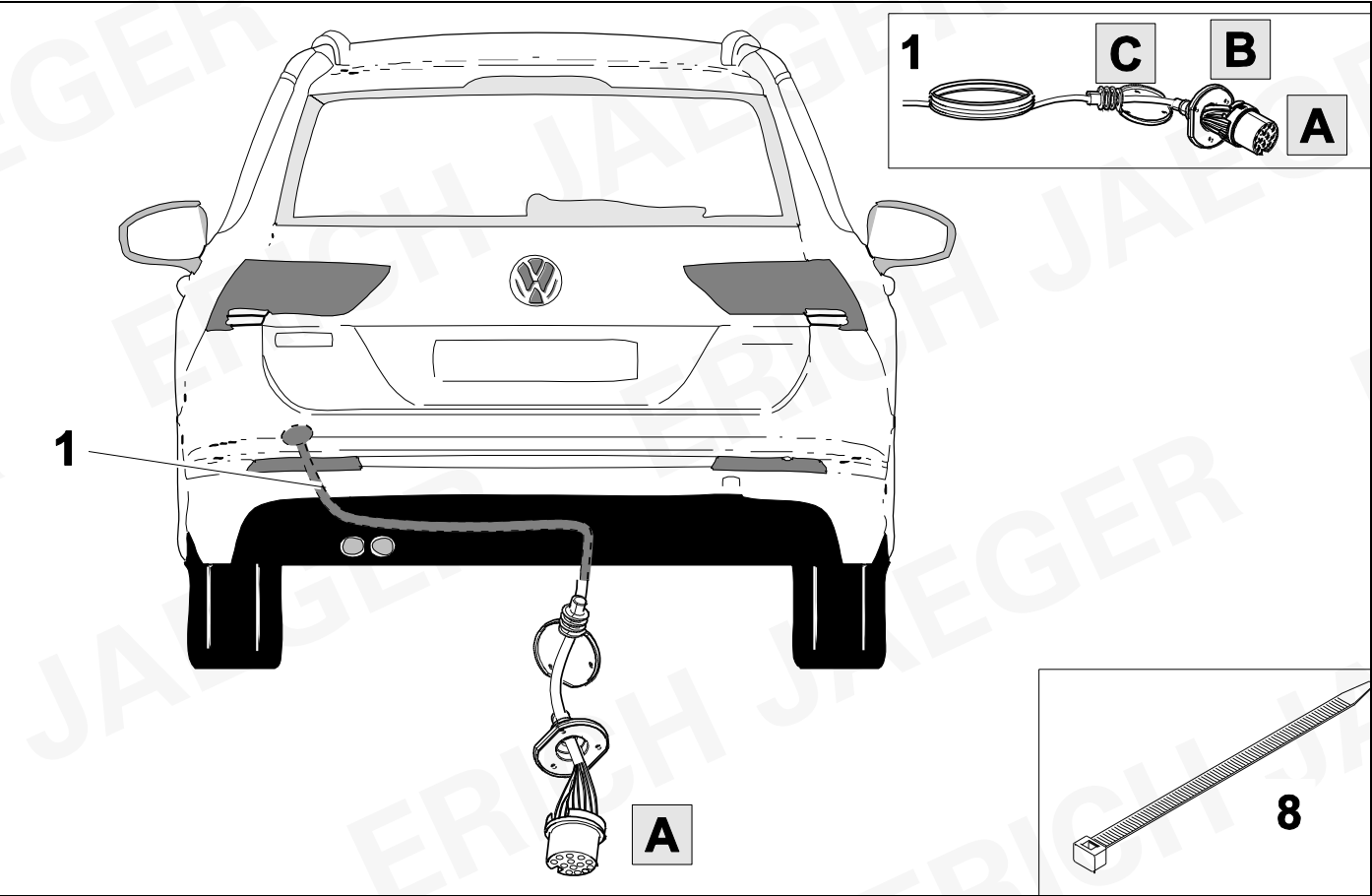

5

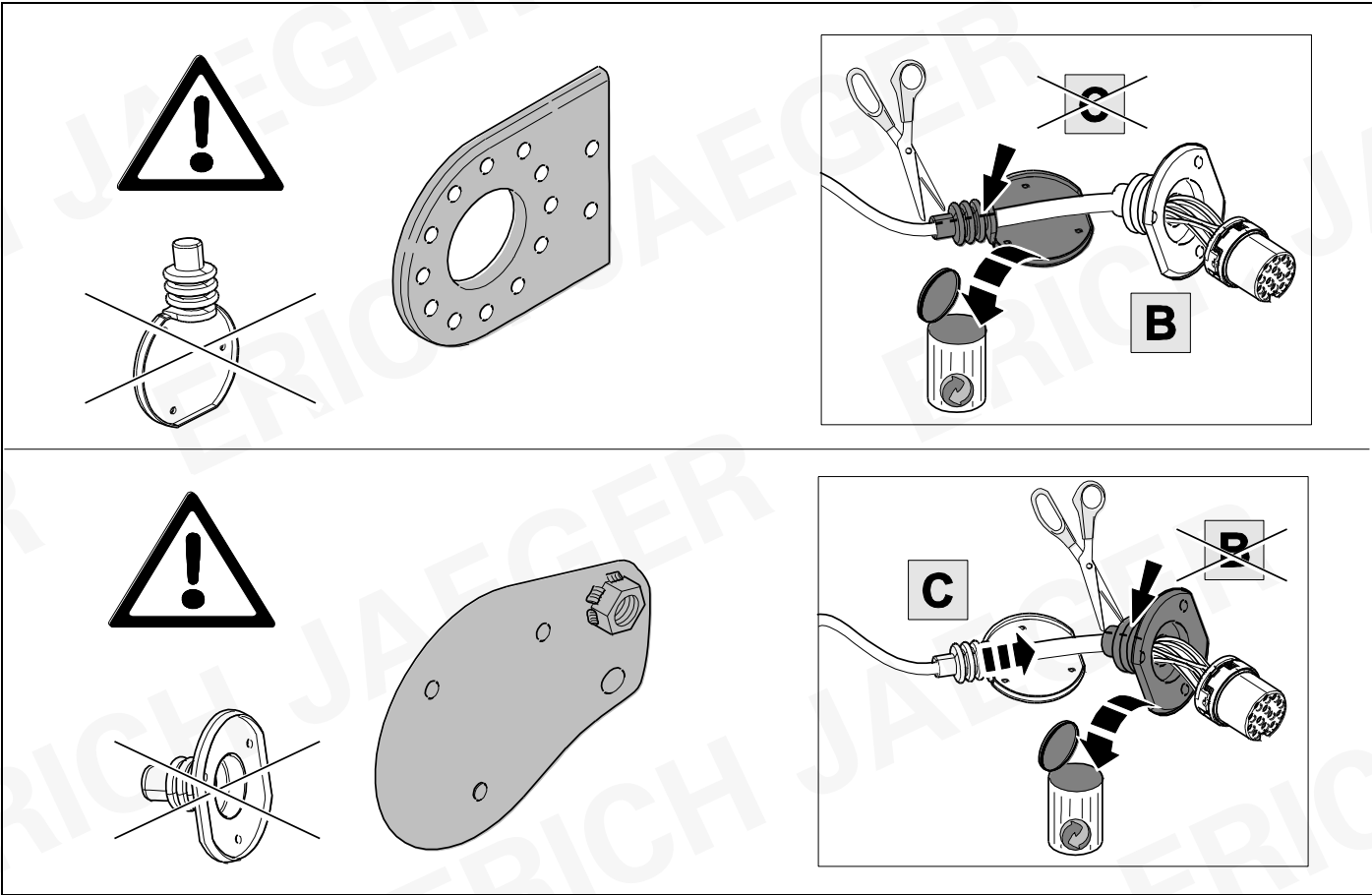

6



8

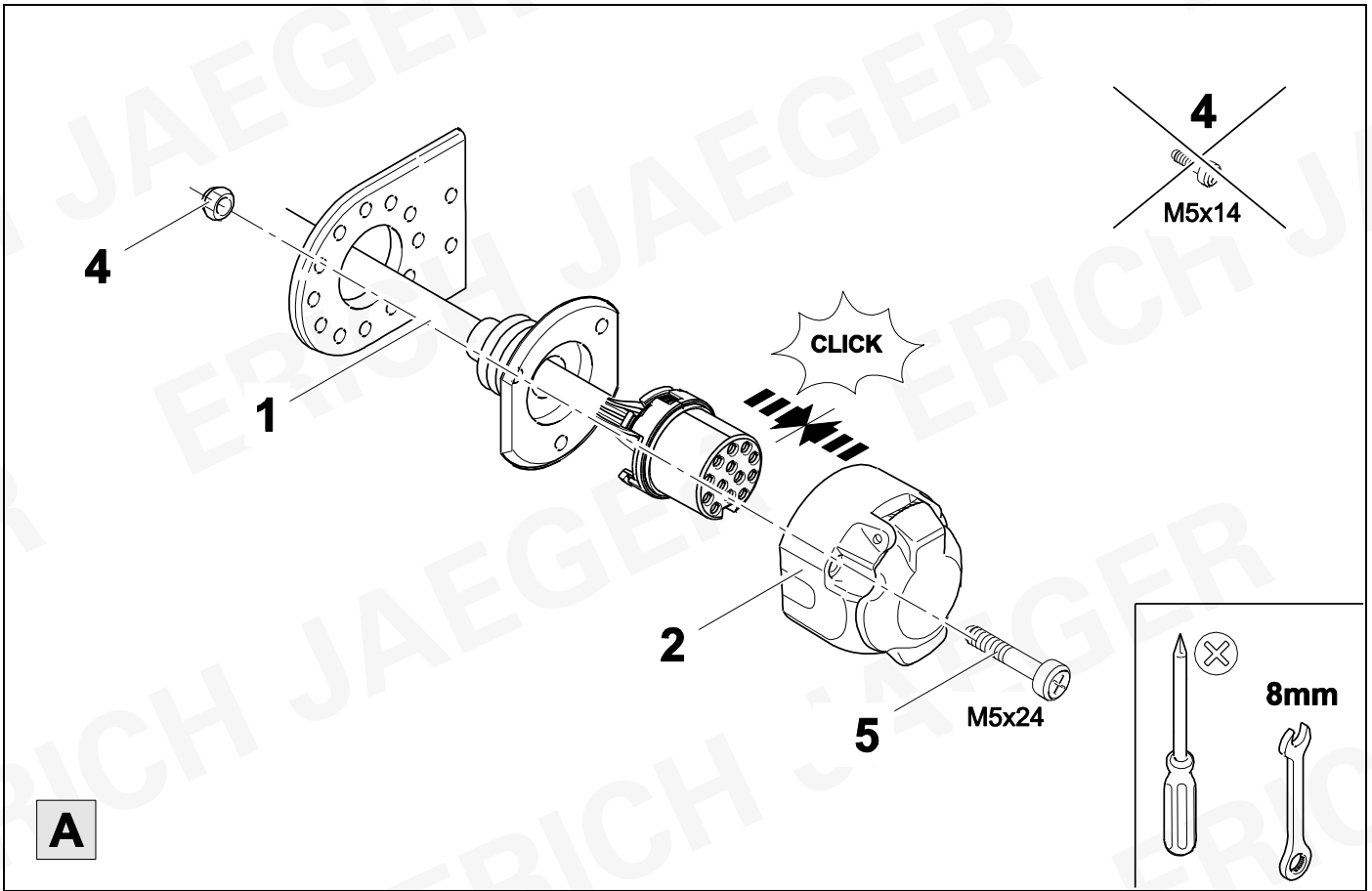

7



8

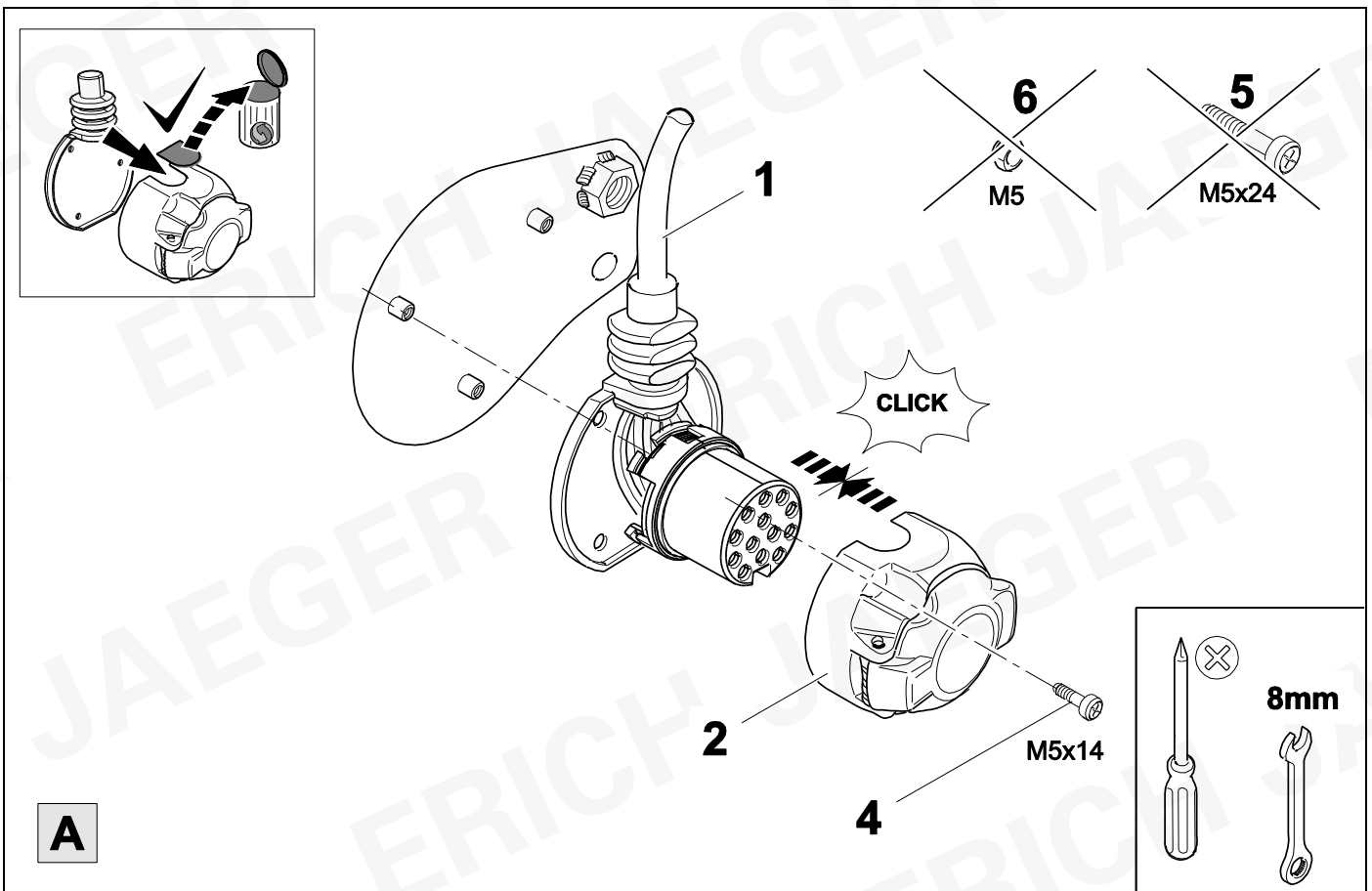

8



9

1	bk/wh		8	bu/rd	
2	gy		9	rd/bu	
3	wh/bn		10	ye	
4	bk/gn		11	bn/gn	
5	gy/rd		12	no	
6	bk/rd		13	bn	
7	gy/bk				

9	bk	wh	gy	gn	rd	bu	ye	bn	pu	or	no
<b>(D)</b>	schwarz	weiß	grau	grün	rot	blau	gelb	braun	violett	orange	nicht belegt
<b>(GB)</b>	black	white	grey	green	red	blue	yellow	brown	purple	orange	not occupied
<b>(F)</b>	noir	blanc	gris	vert	rouge	bleu	jaune	brun	violet	orange	inutilisé
<b>(NL)</b>	zwart	wit	grijs	groen	rood	blauw	geel	bruin	violet	oranje	niet aangesloten
<b>(DK)</b>	sort	hvid	grå	grøn	rød	blå	gul	brun	violet	orange	ikke anvendt
<b>(N)</b>	svart	hvit	grå	grønn	rød	blå	gul	brun	fiolett	oransje	ikke i bruk
<b>(S)</b>	svart	vit	grå	grön	röd	blå	gul	brun	violett	orange	ej använd
<b>(FIN)</b>	musta	valkoinen	harmaa	vihreä	punainen	sininen	keltainen	ruskea	violetti	oranssi	ei varattu
<b>(I)</b>	nero	bianco	grigio	verde	rosso	blu	giallo	marrone	viola	arancione	libero
<b>(E)</b>	negro	blanco	gris	verde	rojo	azul	amarillo	marrón	violeta	anaranja-do	no ocupado
<b>(P)</b>	preto	branco	cinzento	verde	vermelho	azul	amarelo	castanho	violeta	laranja	não ocupado
<b>(GR)</b>	μαύρος	λευκός	Γκρι	πράσινος	κόκκινος	μπλε	κίτρινος	καφέ	Μωβ	πορτοκαλί	δεν είναι κατ'επιτημένος
<b>(PL)</b>	czarny	biały	szary	zielony	czerwony	niebiesko	żółty	brazowy	fioletowy	pomarańczowy	wolny
<b>(CZ)</b>	černý	bílý	šedý	zelený	červený	modrý	žlutý	hnědý	fialový	oranžový	neobsazen
<b>(TR)</b>	siyah	beyaz	gri	yeşil	kırmızı	mavi	sarı	kahverengi	mor	portakal rengi	boş
<b>(H)</b>	fekete	fehér	szürke	zöld	piros	kék	sárga	barna	ibolyakék	narancssárga	nem foglalt
<b>(HR)</b>	crno	bijelo	sivo	zeleno	crveno	plavo	zuto	smeđe	ljubičasto	narandžasto	nije zauzeto
<b>(BUL)</b>	черен	бял	сив	зелен	червен	син	жълт	кафяв	виолетов	оранжев	свободно
<b>(RO)</b>	negru	alb	gri	verde	roșu	albastru	galben	maro	violet	portocaliu	liber
<b>(RU)</b>	черный	белый	серый	зеленый	красный	голубой	жёлтый	коричневый	пурпурный	оранжевый	свободно
<b>(LT)</b>	juoda	balta	pilka	žalia	raudona	mėlyna	geltona	ruda	purpurinė	oranžinė	laisva
<b>(LV)</b>	melna	balta	pelēka	zaļa	sarkana	zila	dzeltena	brūna	purpur-sarkana	oranža	brīvs
<b>(EST)</b>	must	valge	hall	roheline	punane	sinine	kollane	pruun	purpur-punane	oraanž	vaba
<b>(SLO)</b>	črna	bela	siva	zelena	rdeča	modra	rumena	smeđ	vijoličast	oranžen	ni zasedeno
<b>(SK)</b>	čierny	biely	šedý	zelený	červený	modrý	žltý	hnědý	fialový	pomaraňový	neobsadený



10

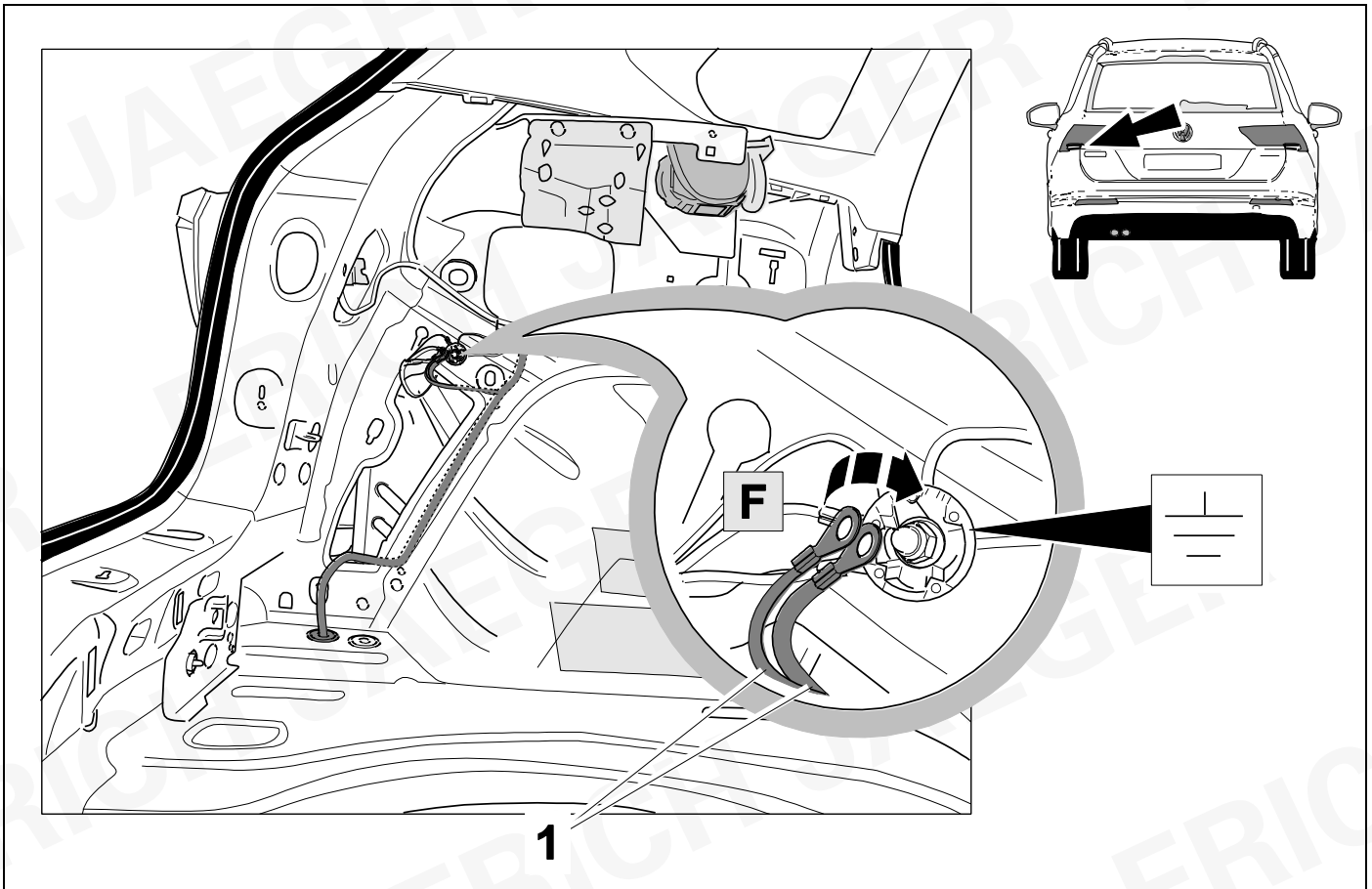

11



**Fahrzeuge mit Anhängervorbereitung**  
**Vehicles with trailer preparation**

6 PIN bk      10 PIN bk

**OPTION 1**

12 ⇒ 19

35 ⇒ 49

**Fahrzeuge ohne Anhängervorbereitung**  
**Vehicles without trailer preparation**

**OPTION 2**

20 ⇒ 49

12

OPTION 1

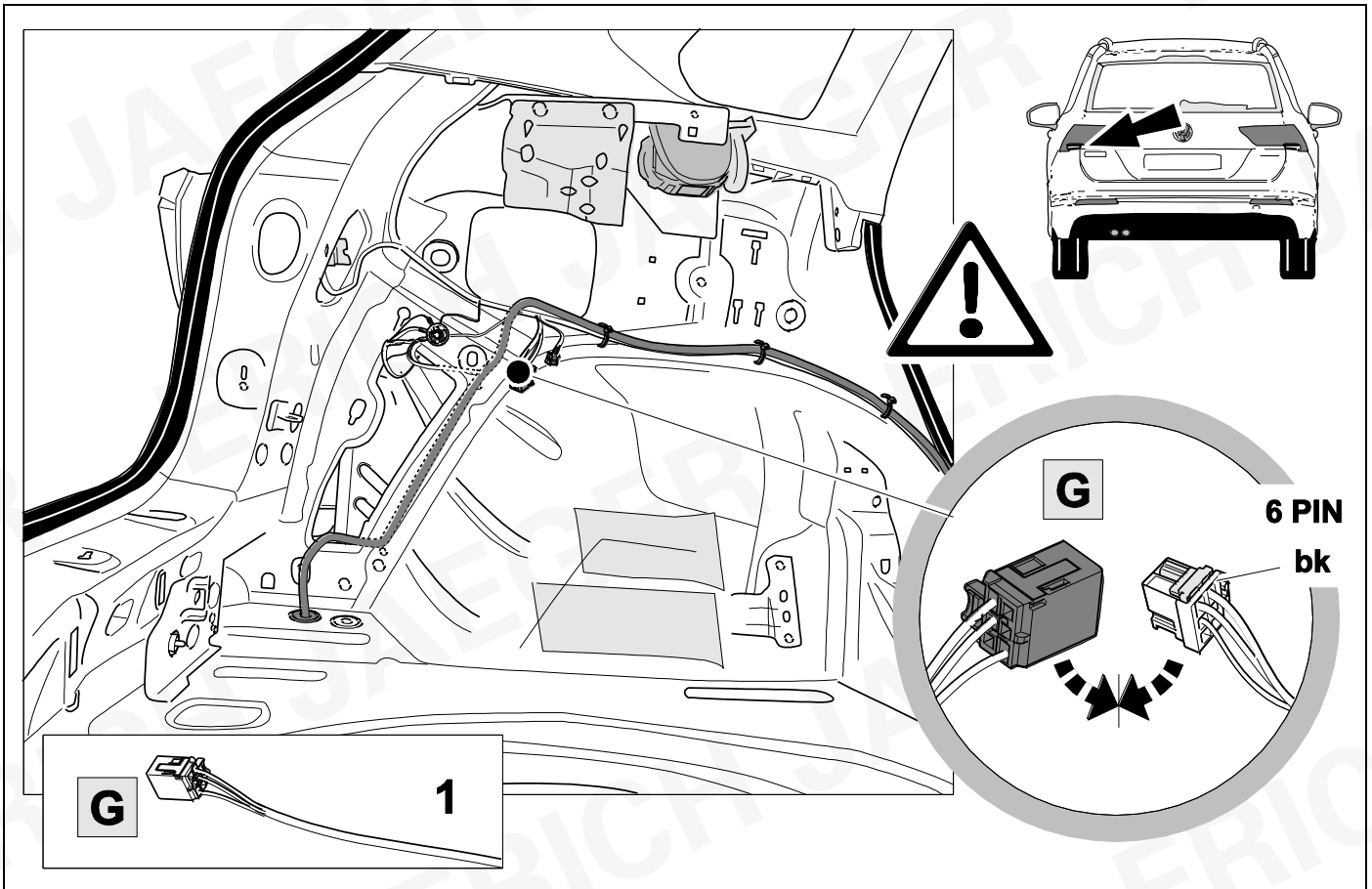

13

OPTION 1

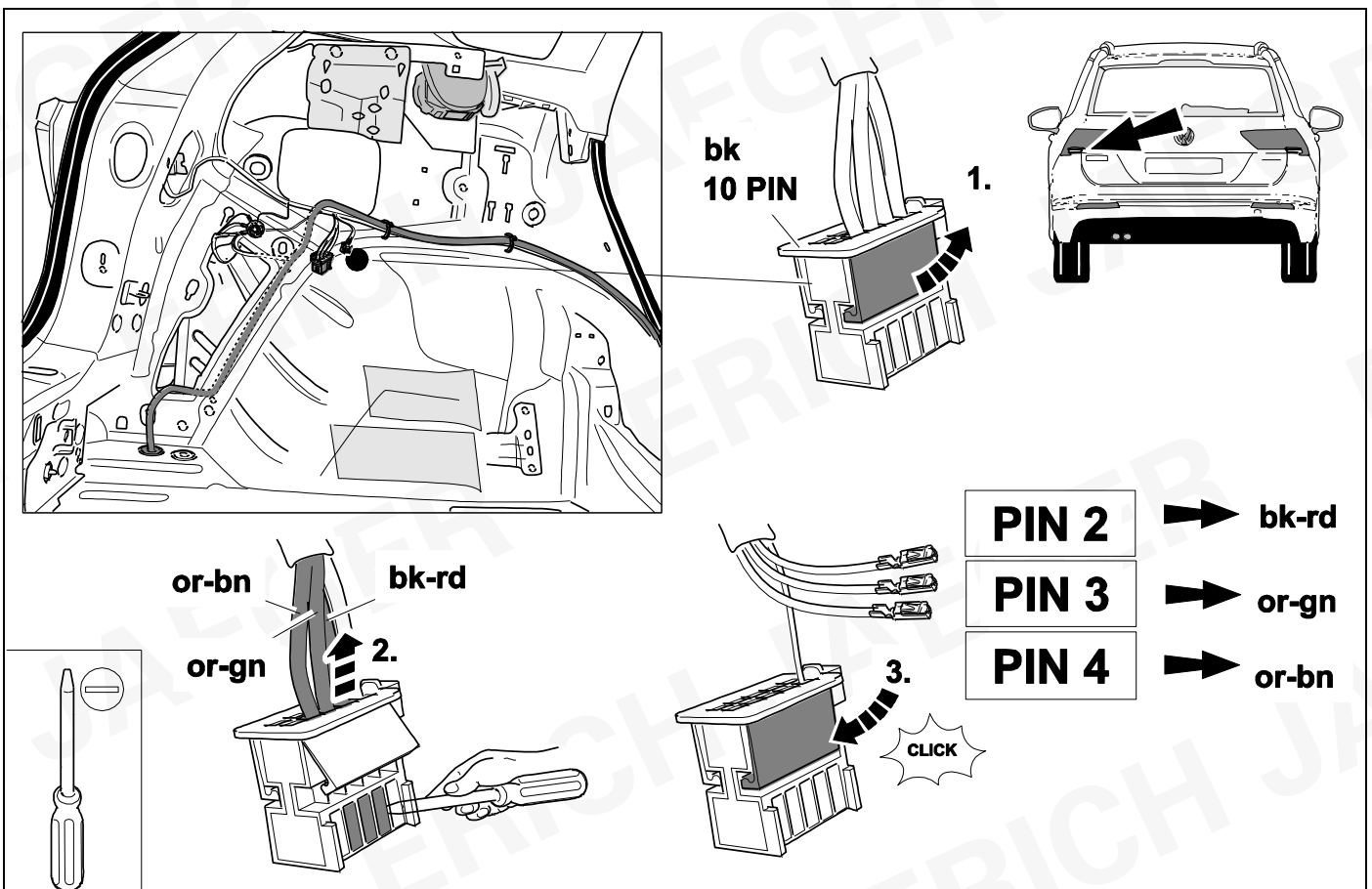

14



9

OPTION 1

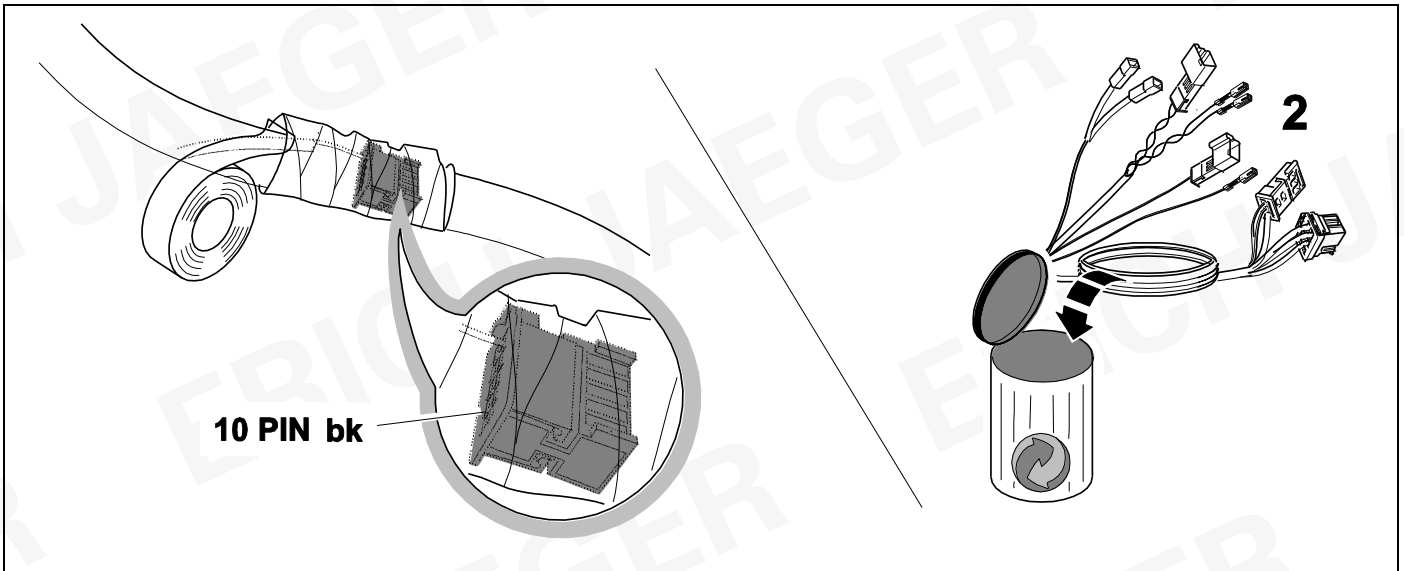

15



9

OPTION 1

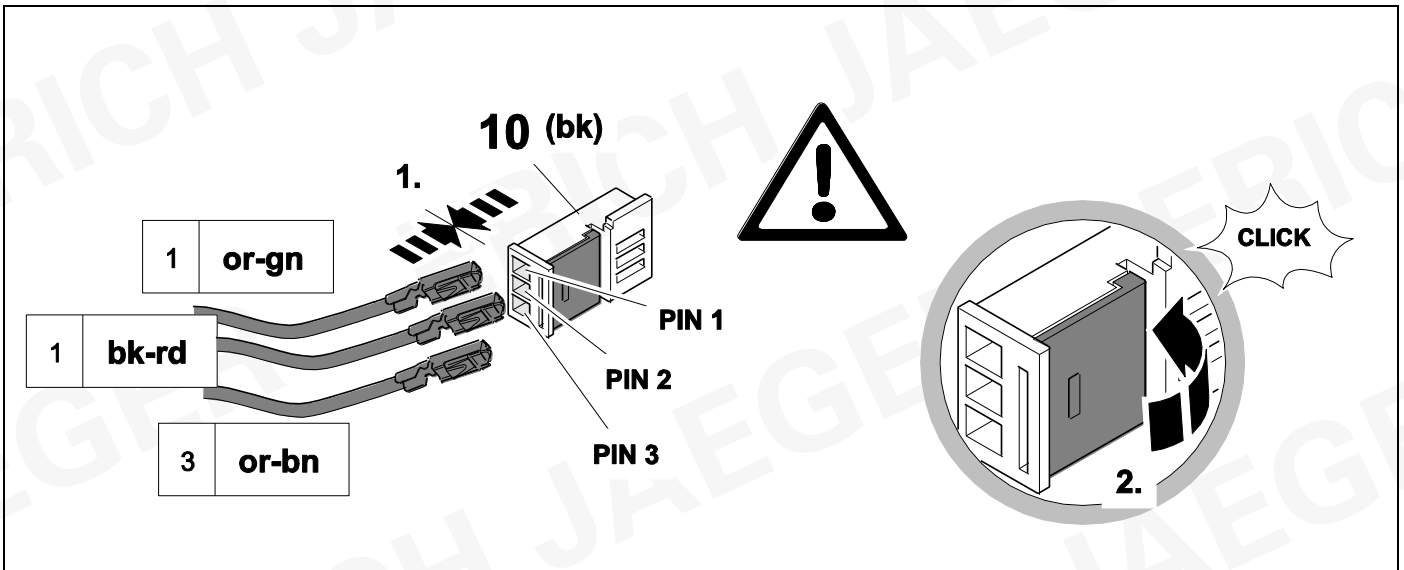

16



9

OPTION 1

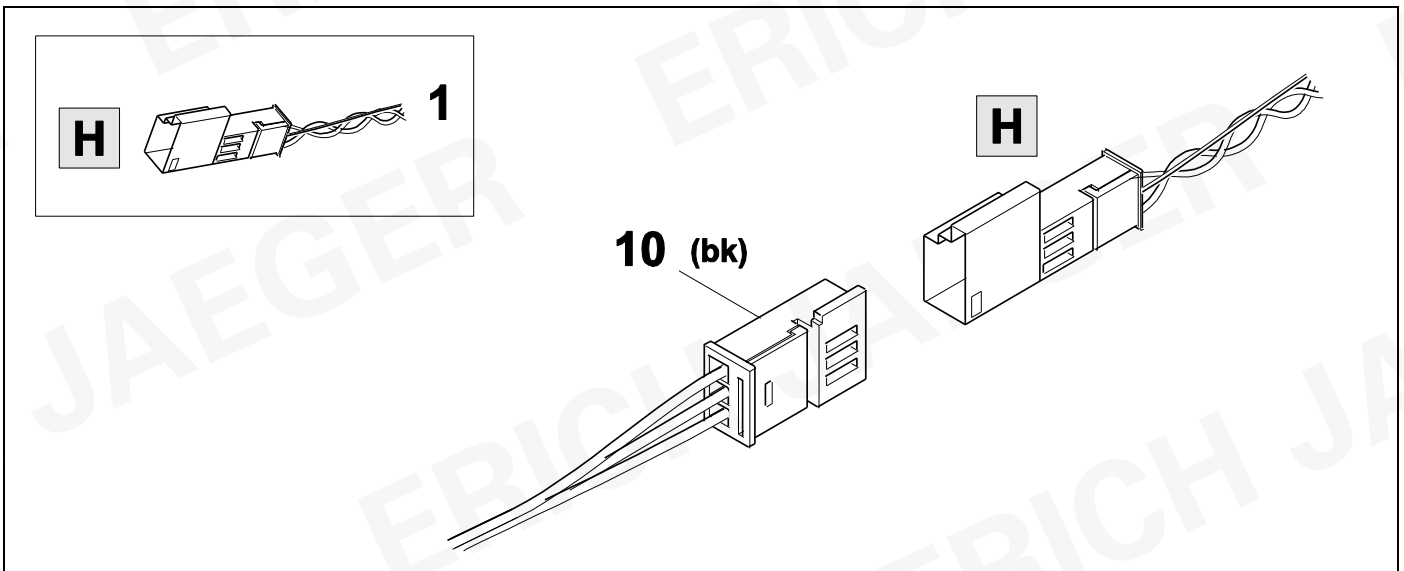

17

OPTION 1

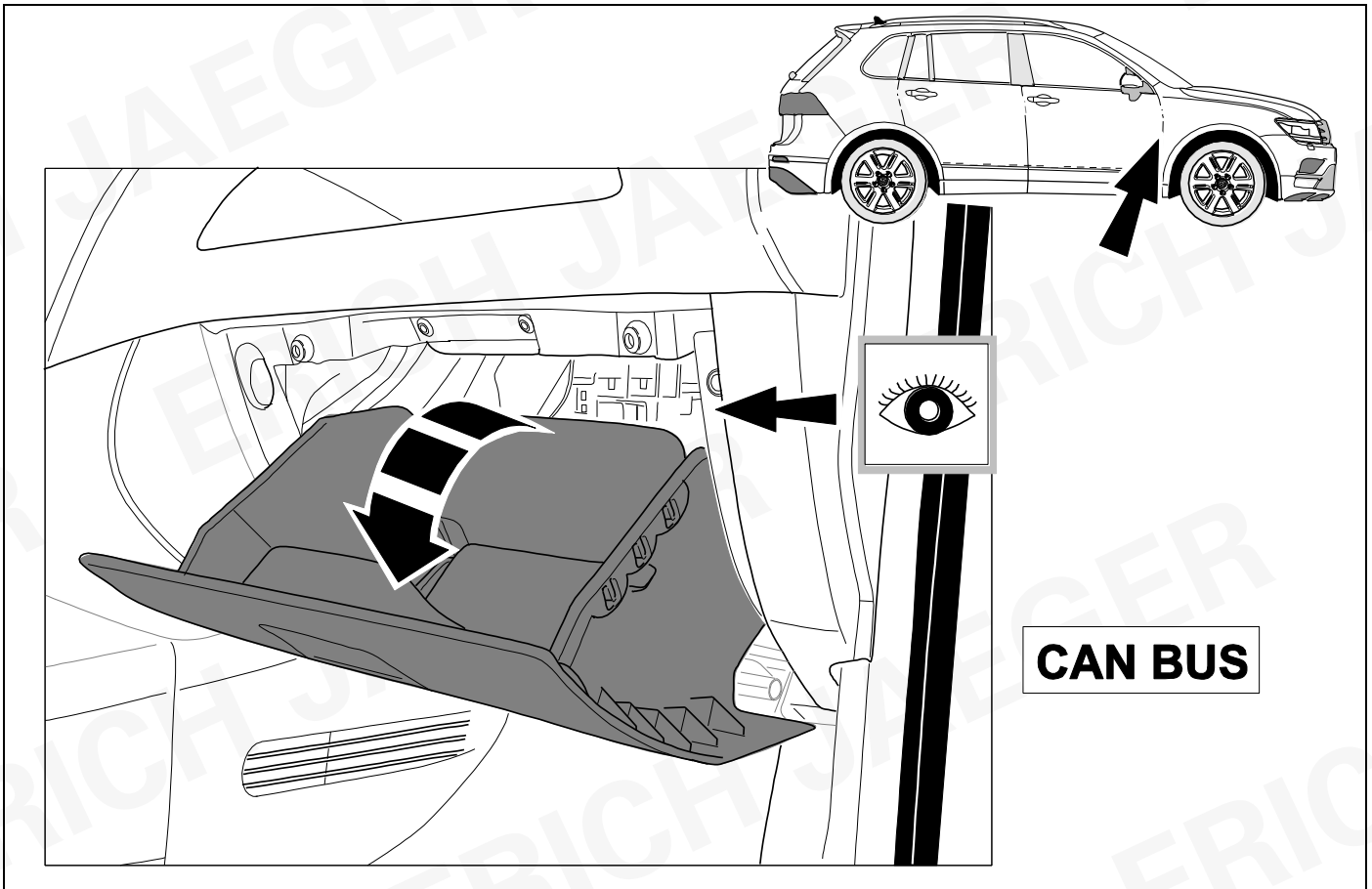

18

OPTION 1

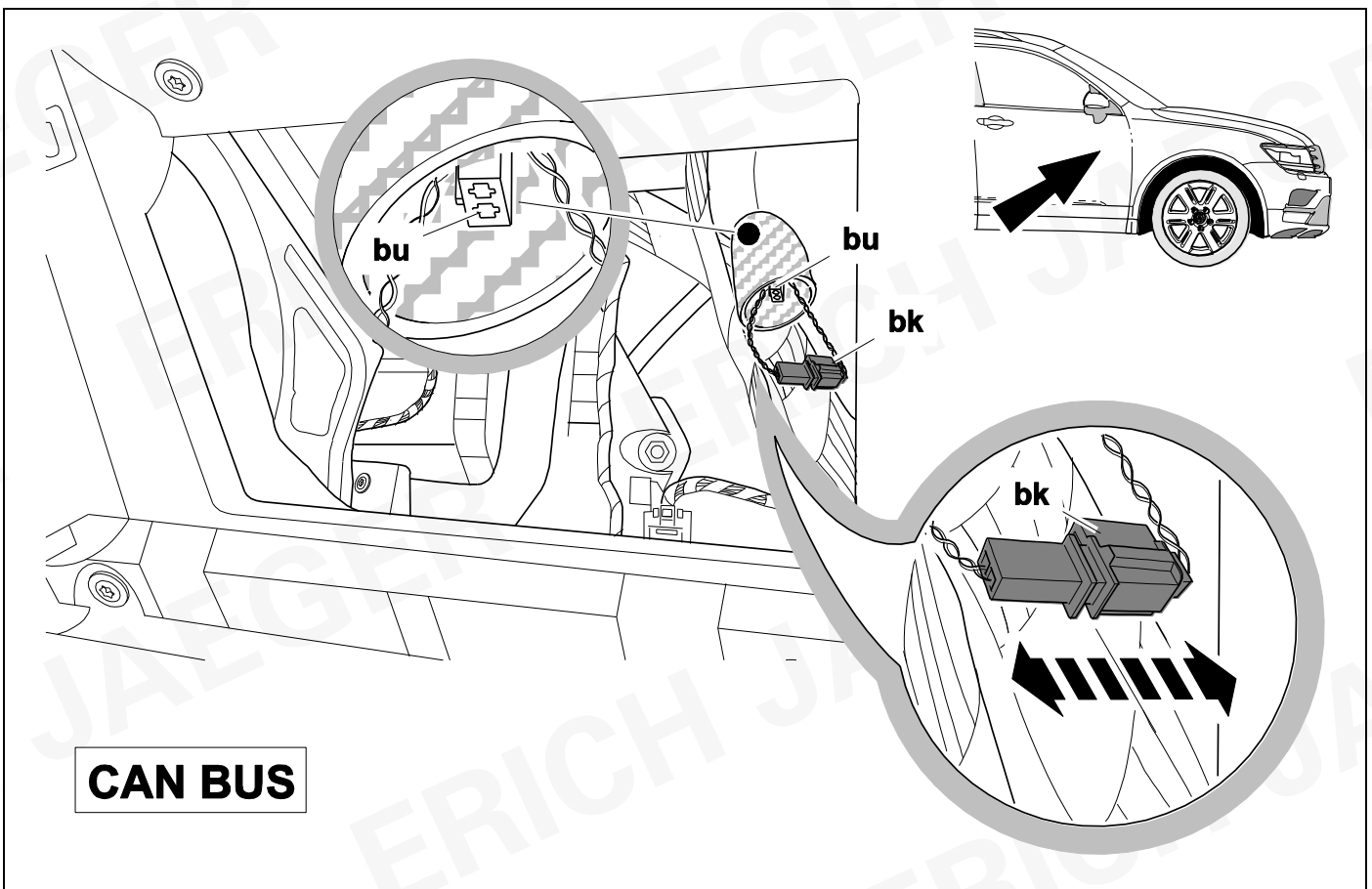

CAN BUS

19

OPTION 1

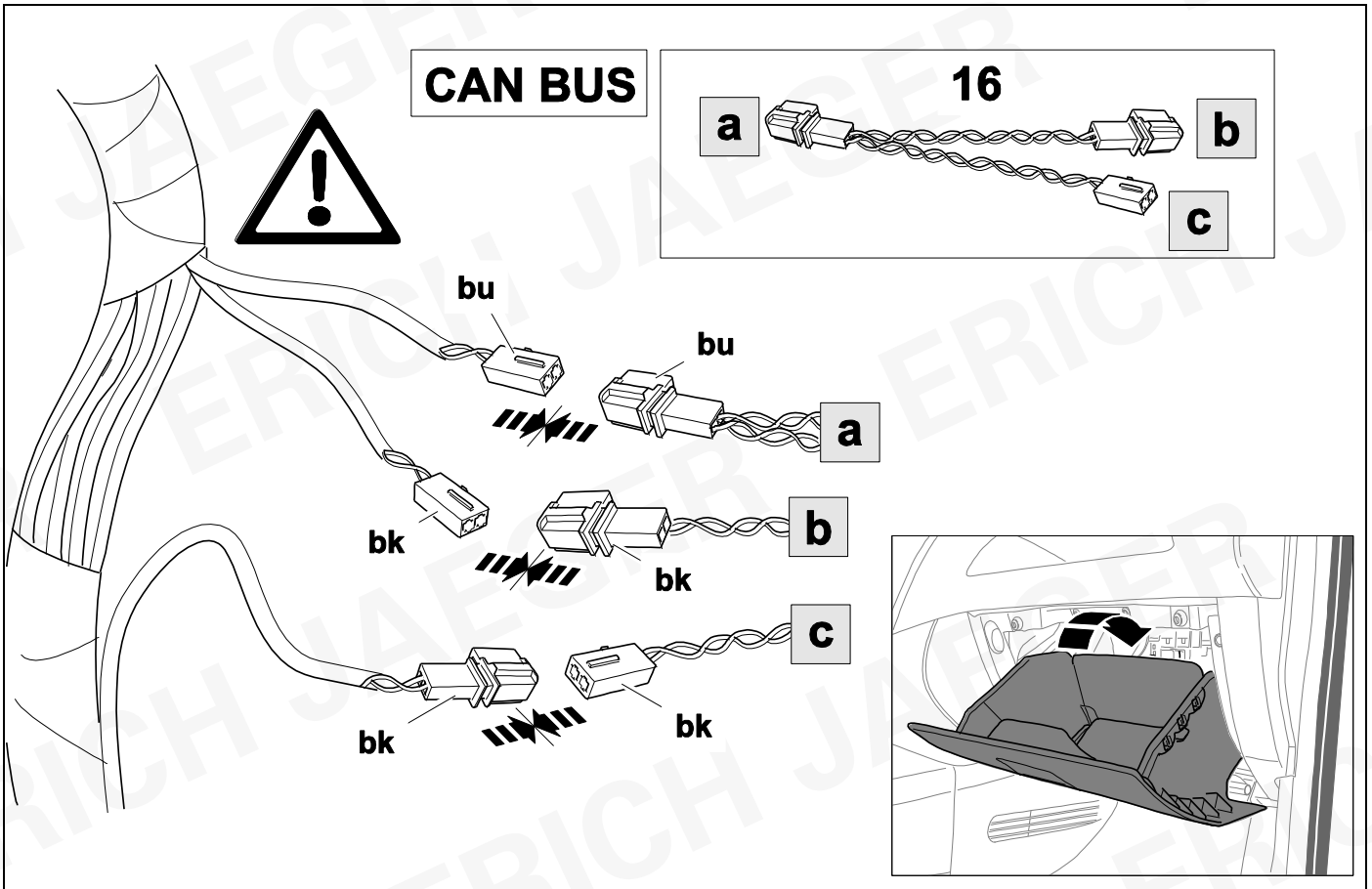

20

Vehicles without trailer preparation

OPTION 2

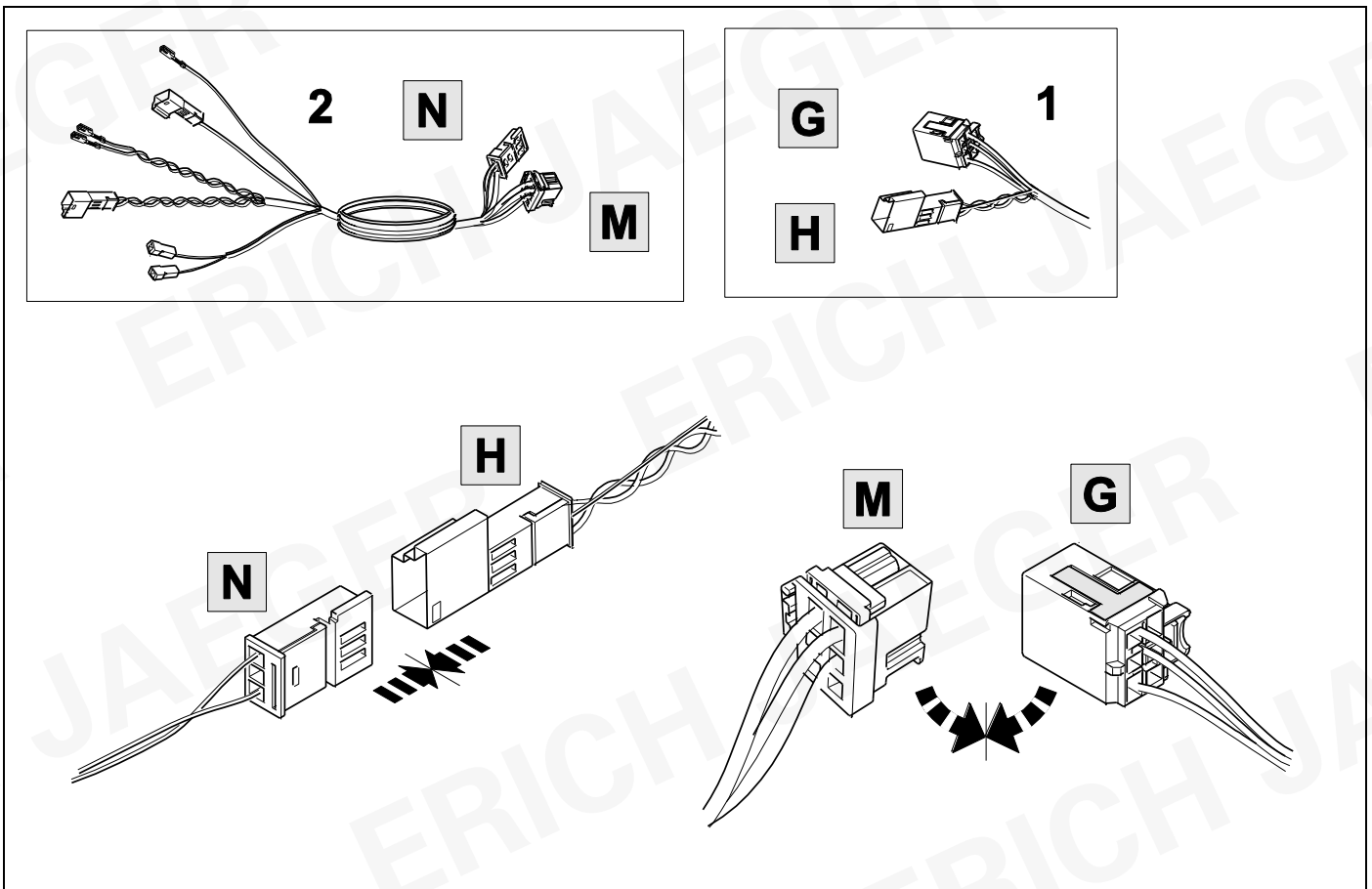

21

OPTION 2

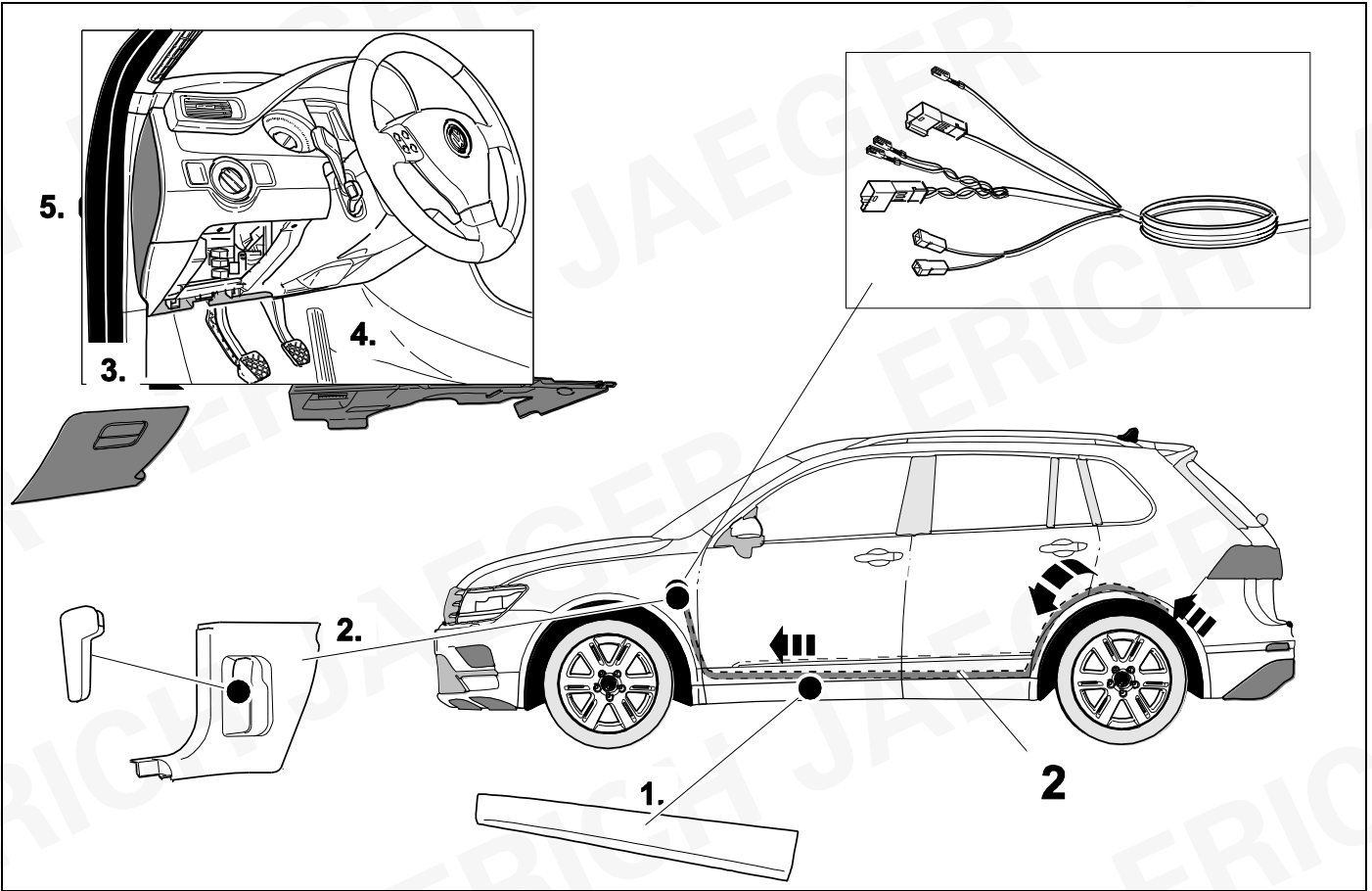

22



9

OPTION 2

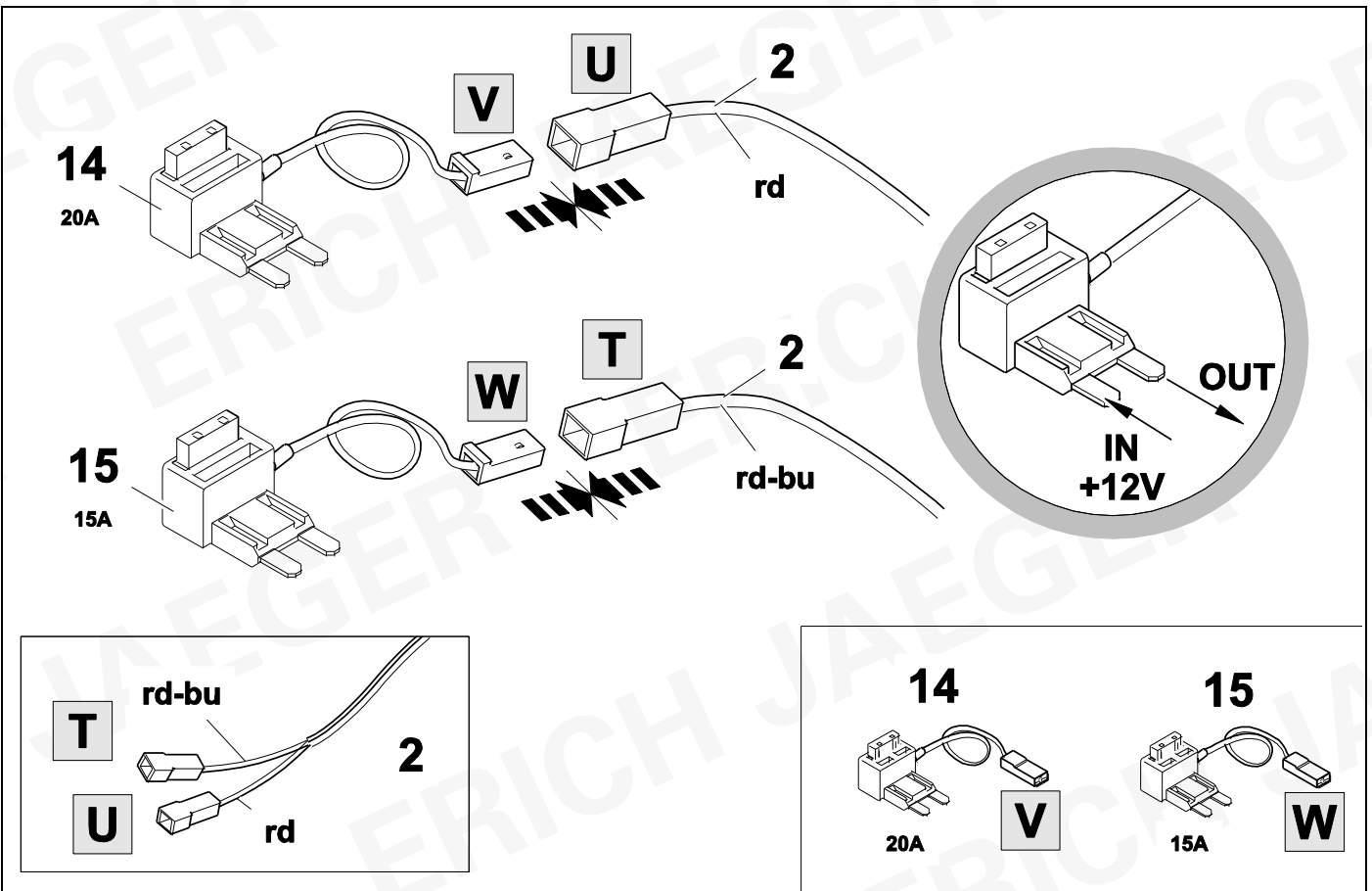

23



42

OPTION 2

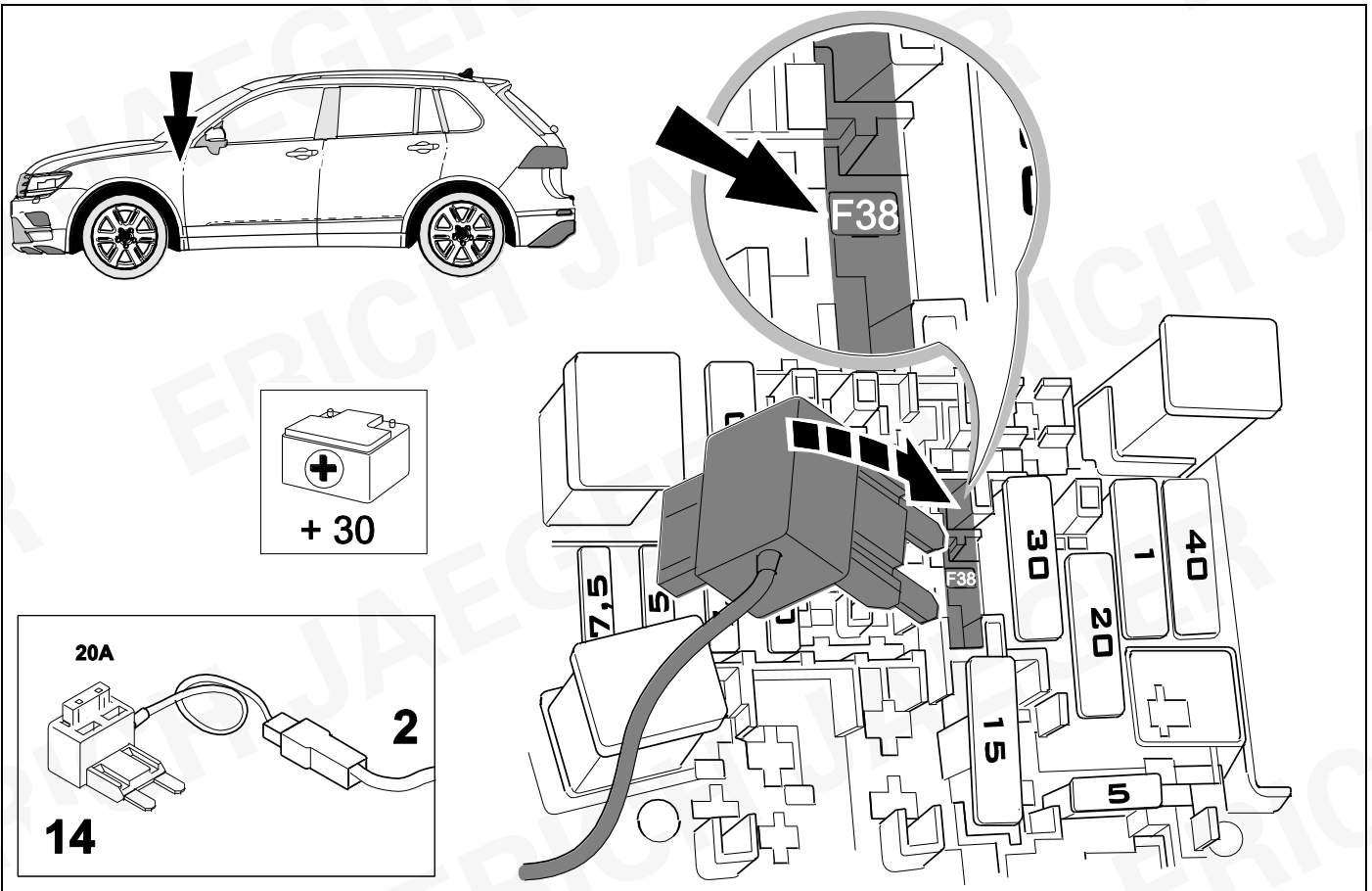

24



42

OPTION 2

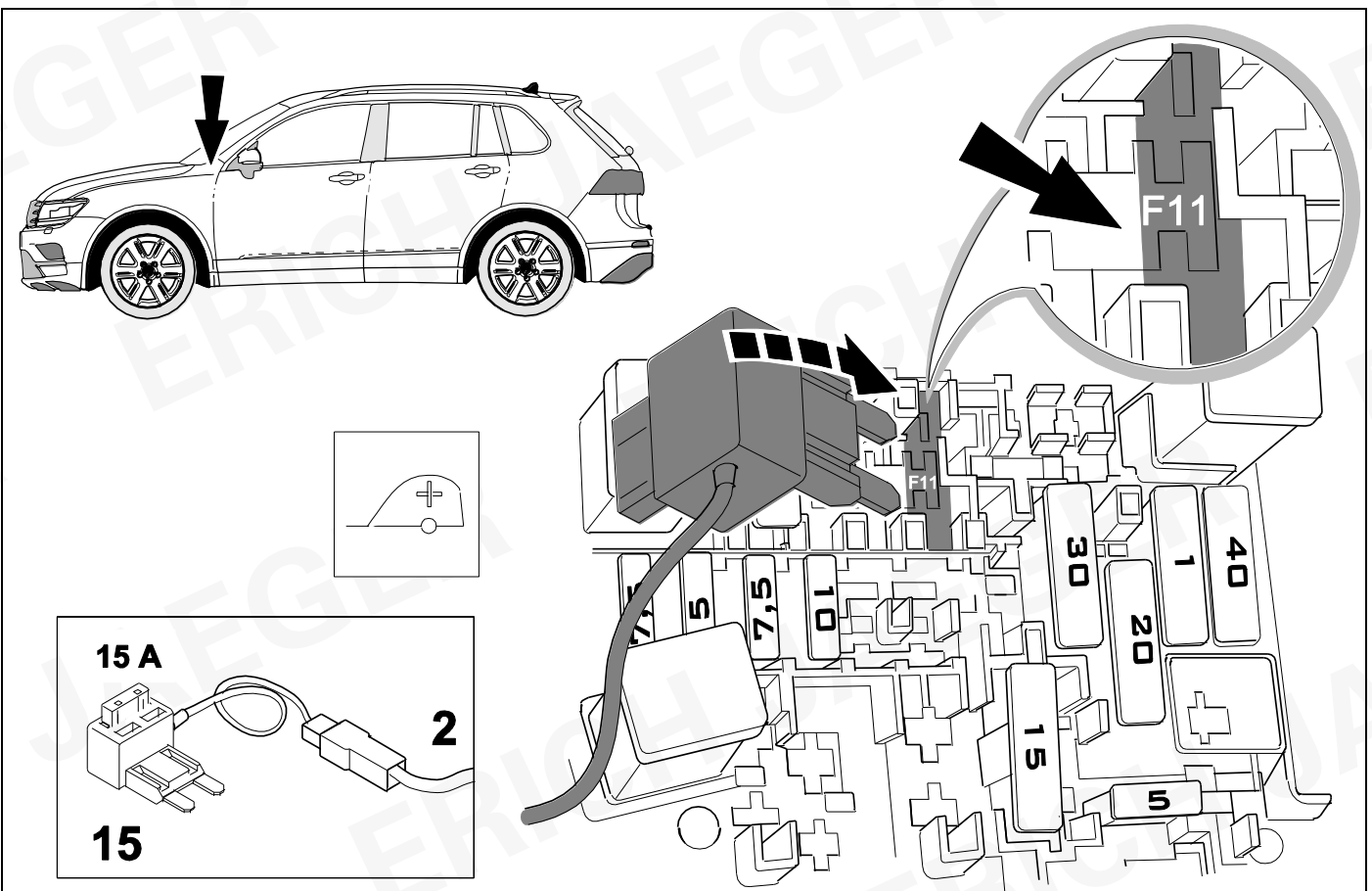

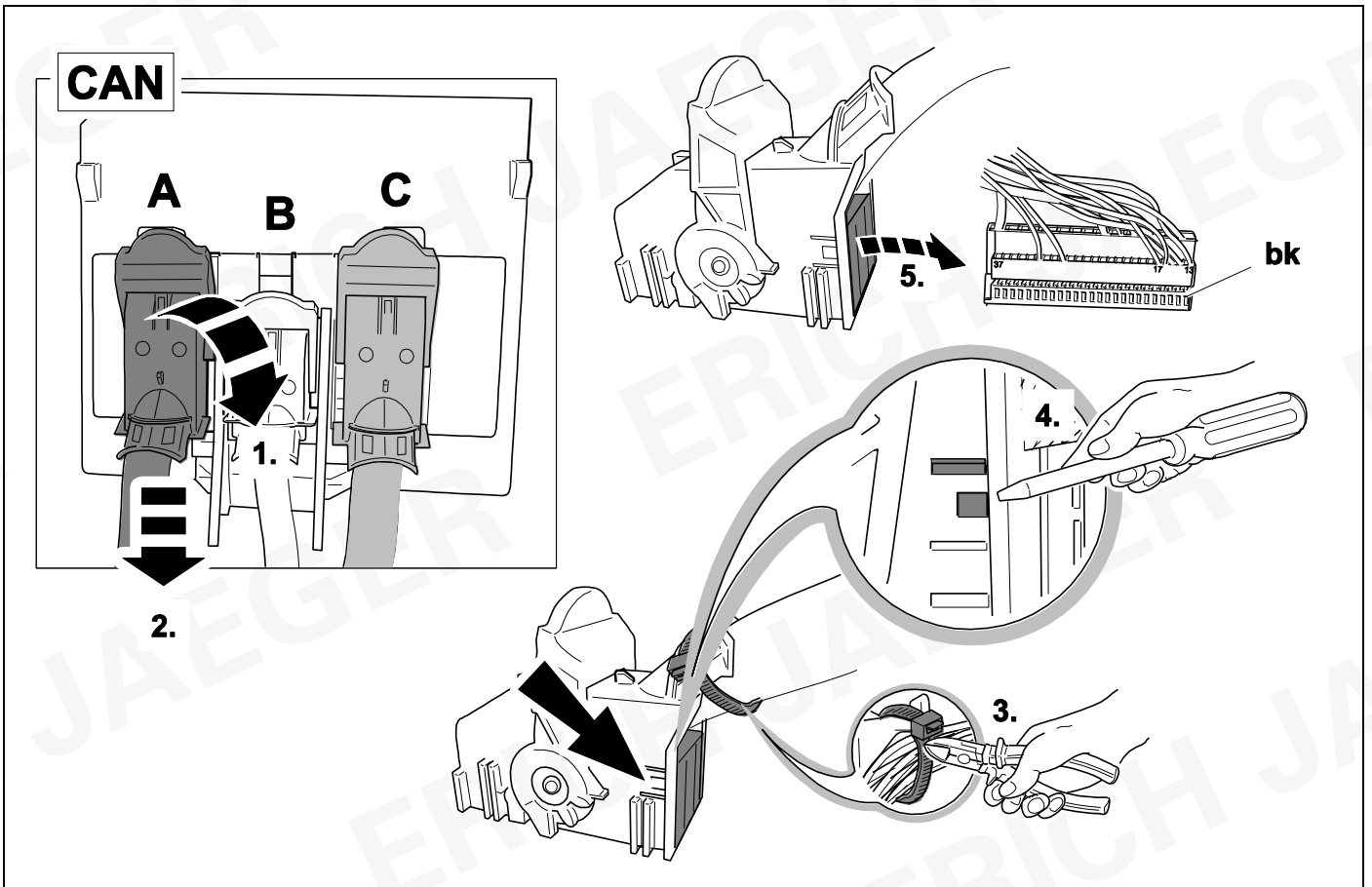
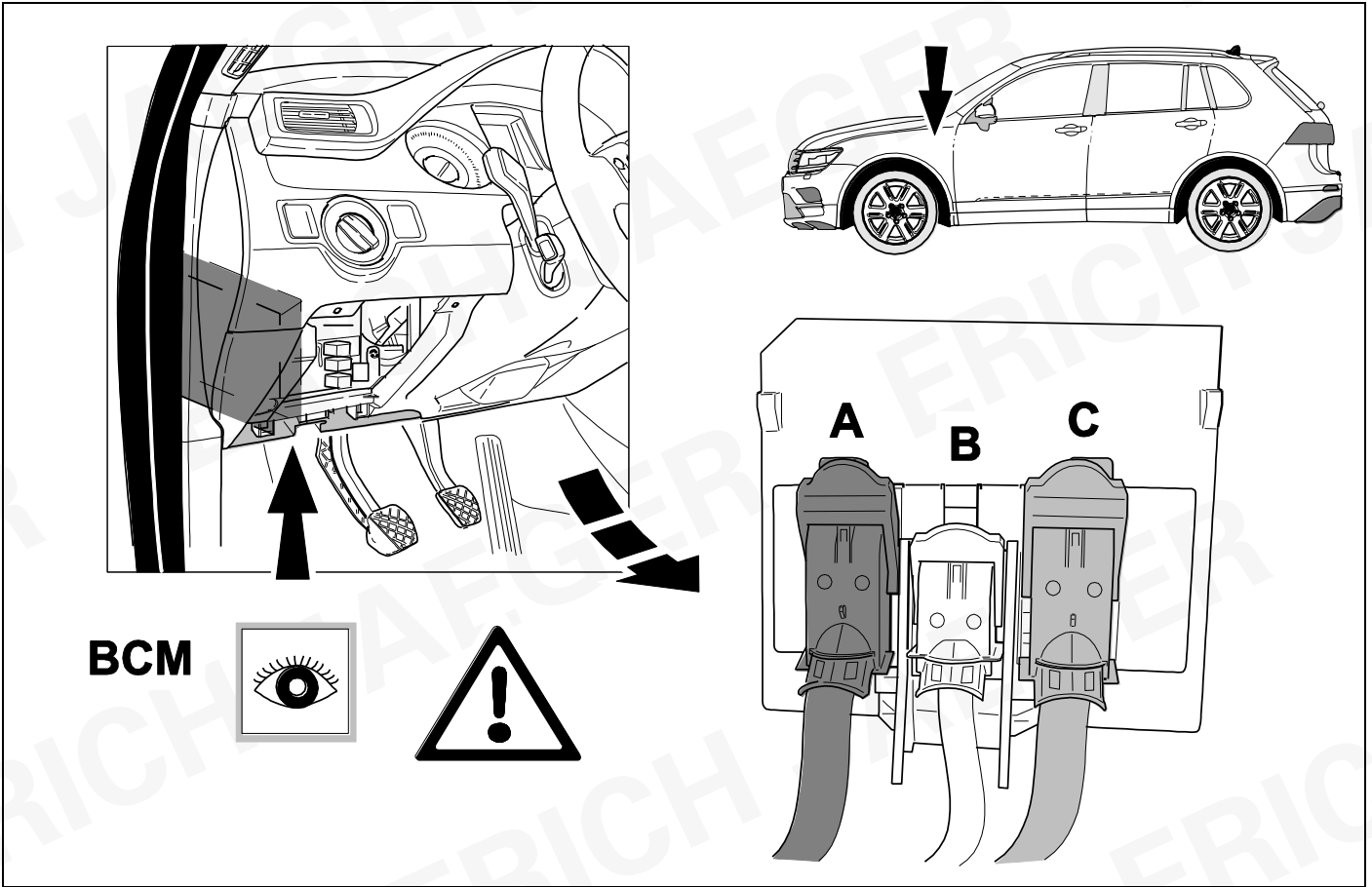



27



9

OPTION 2

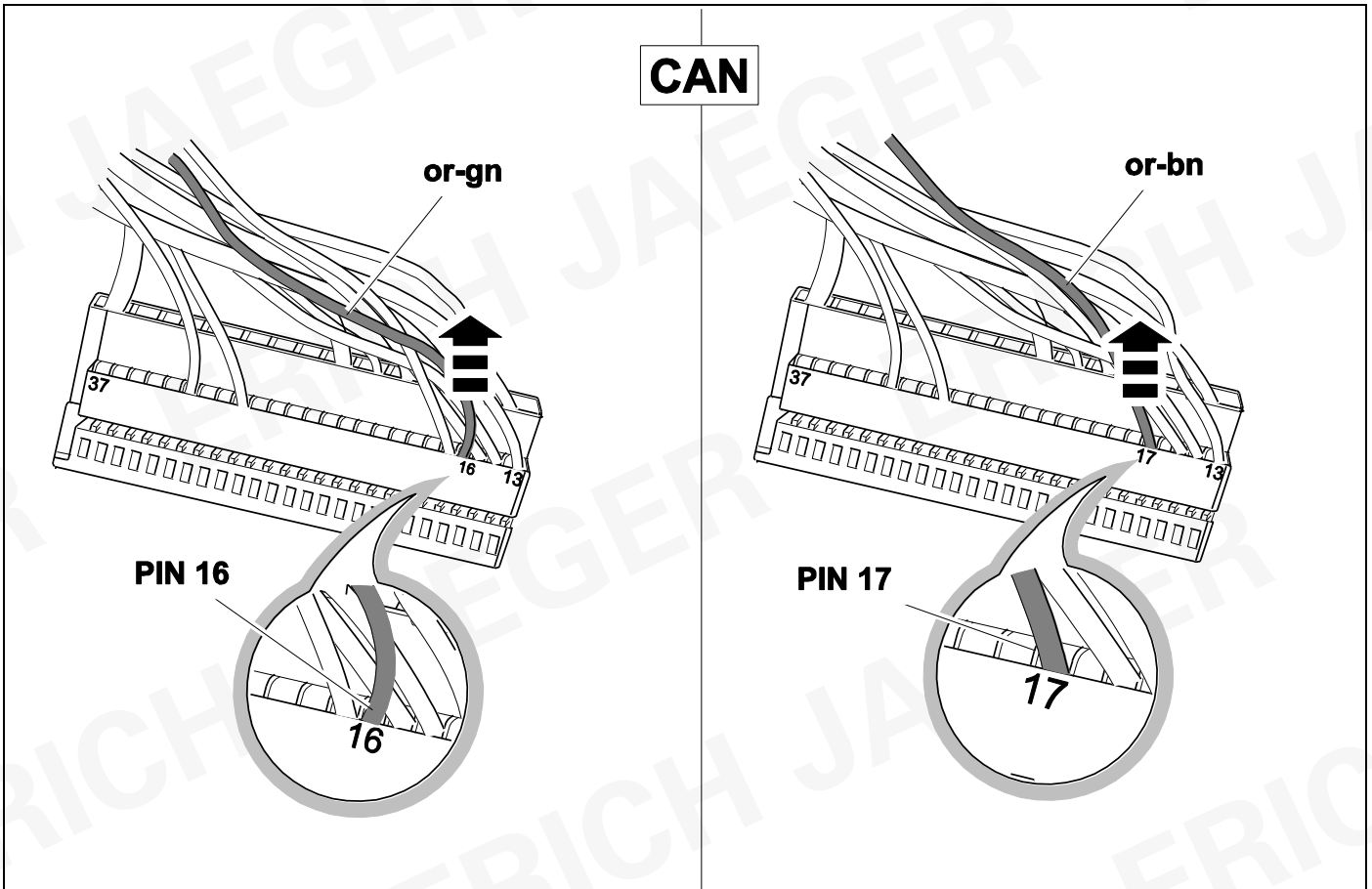

28



9

OPTION 2

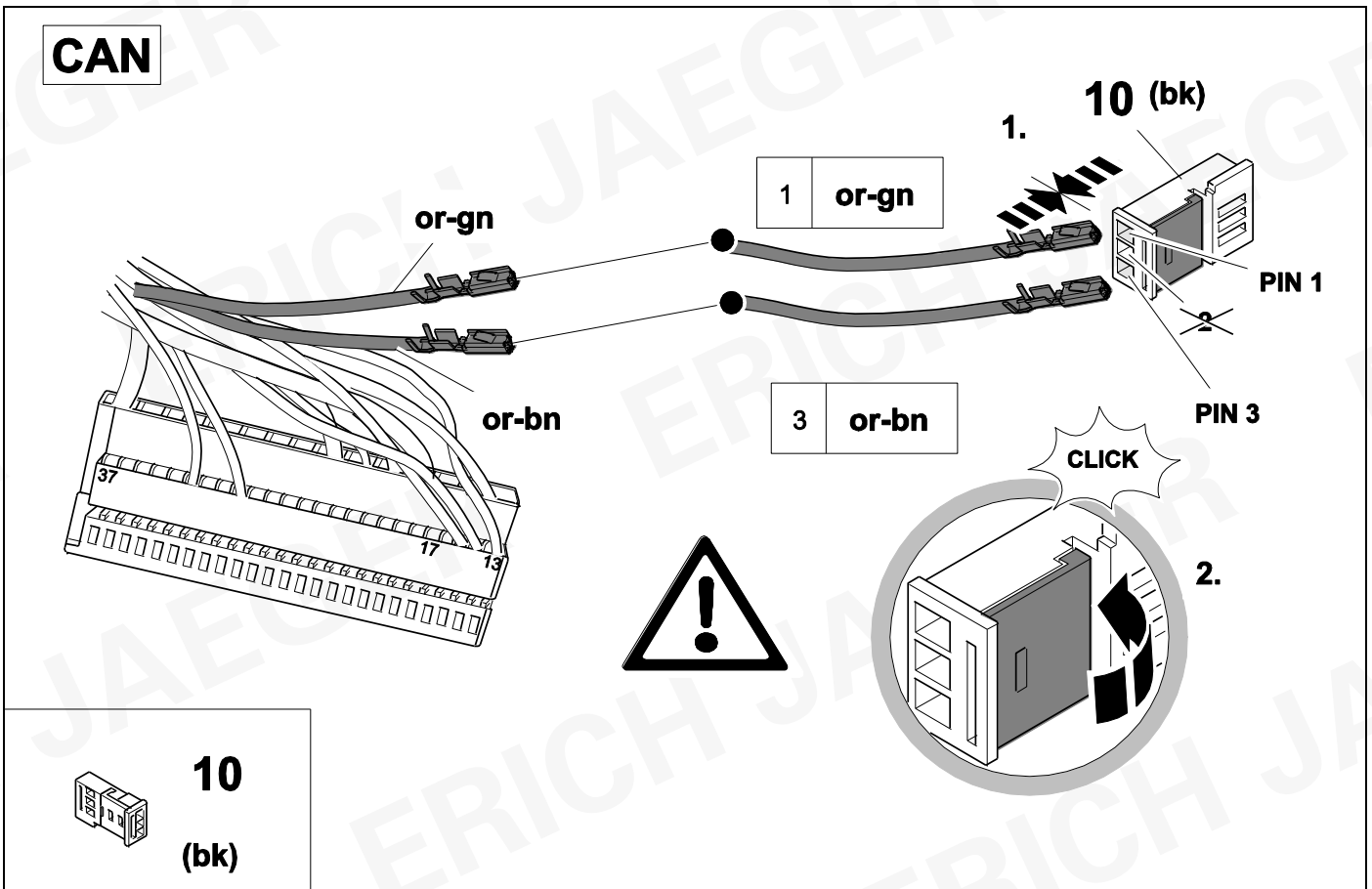

**10**  
**(bk)**

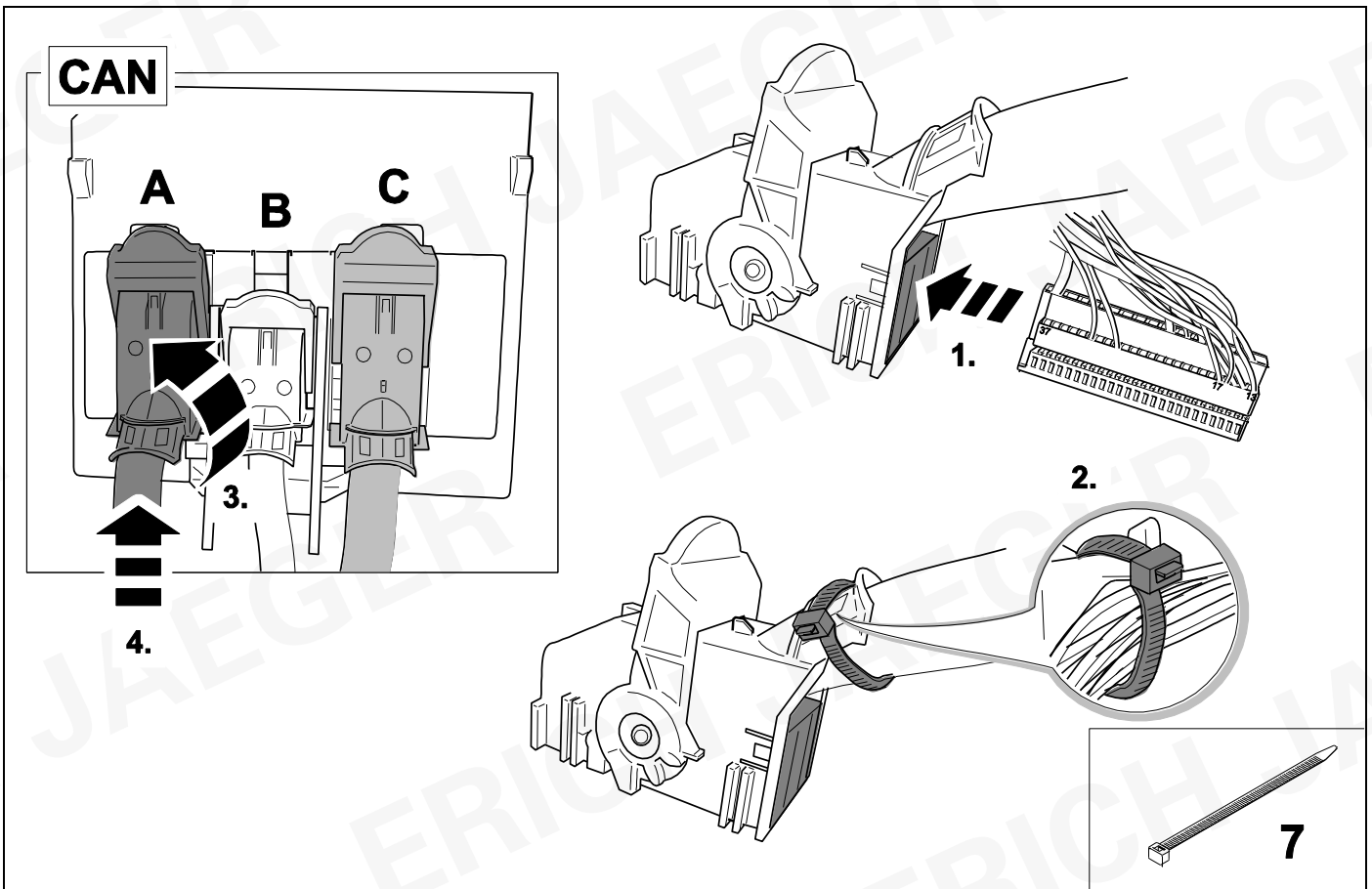
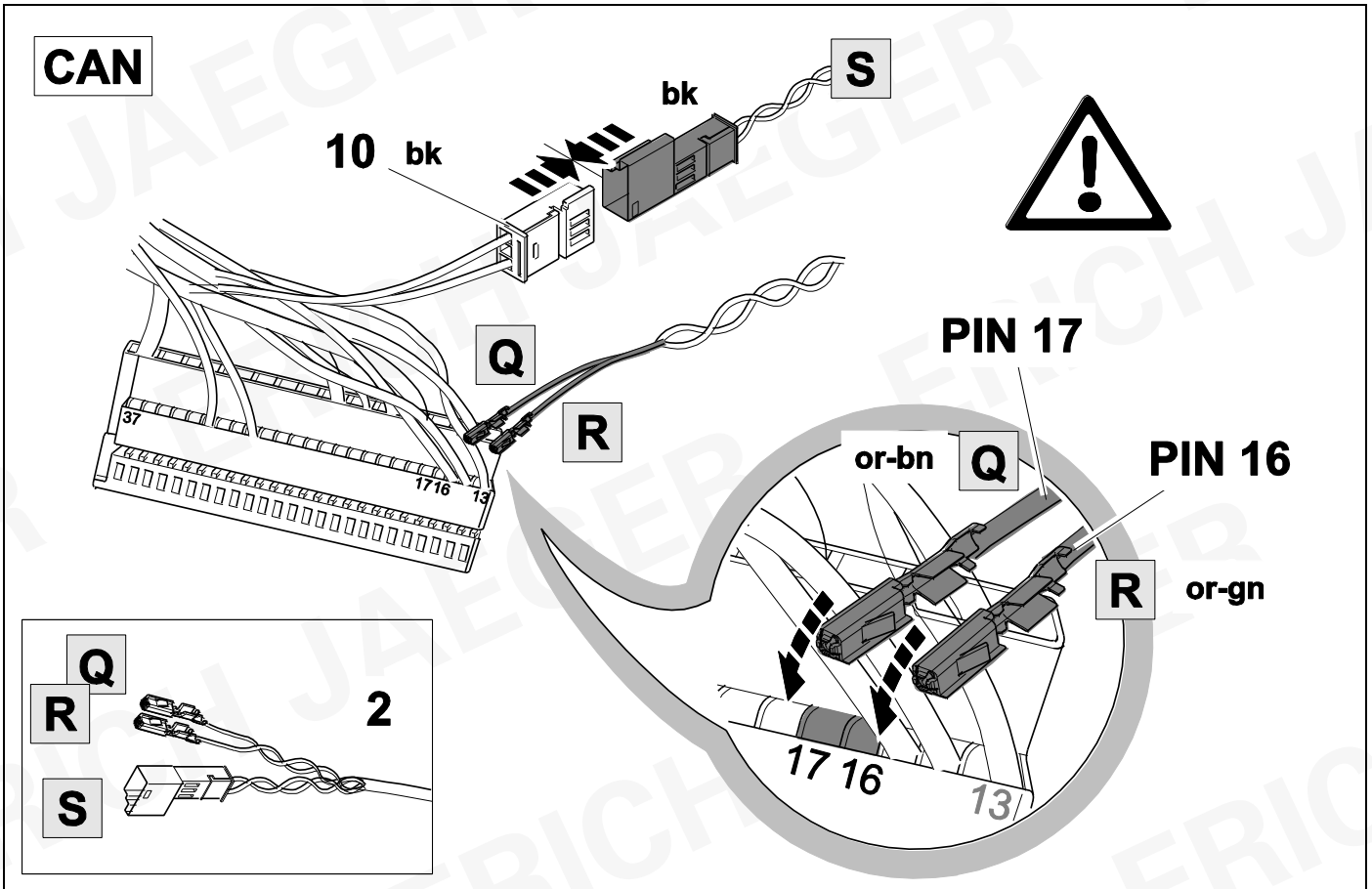

31



9

OPTION 2

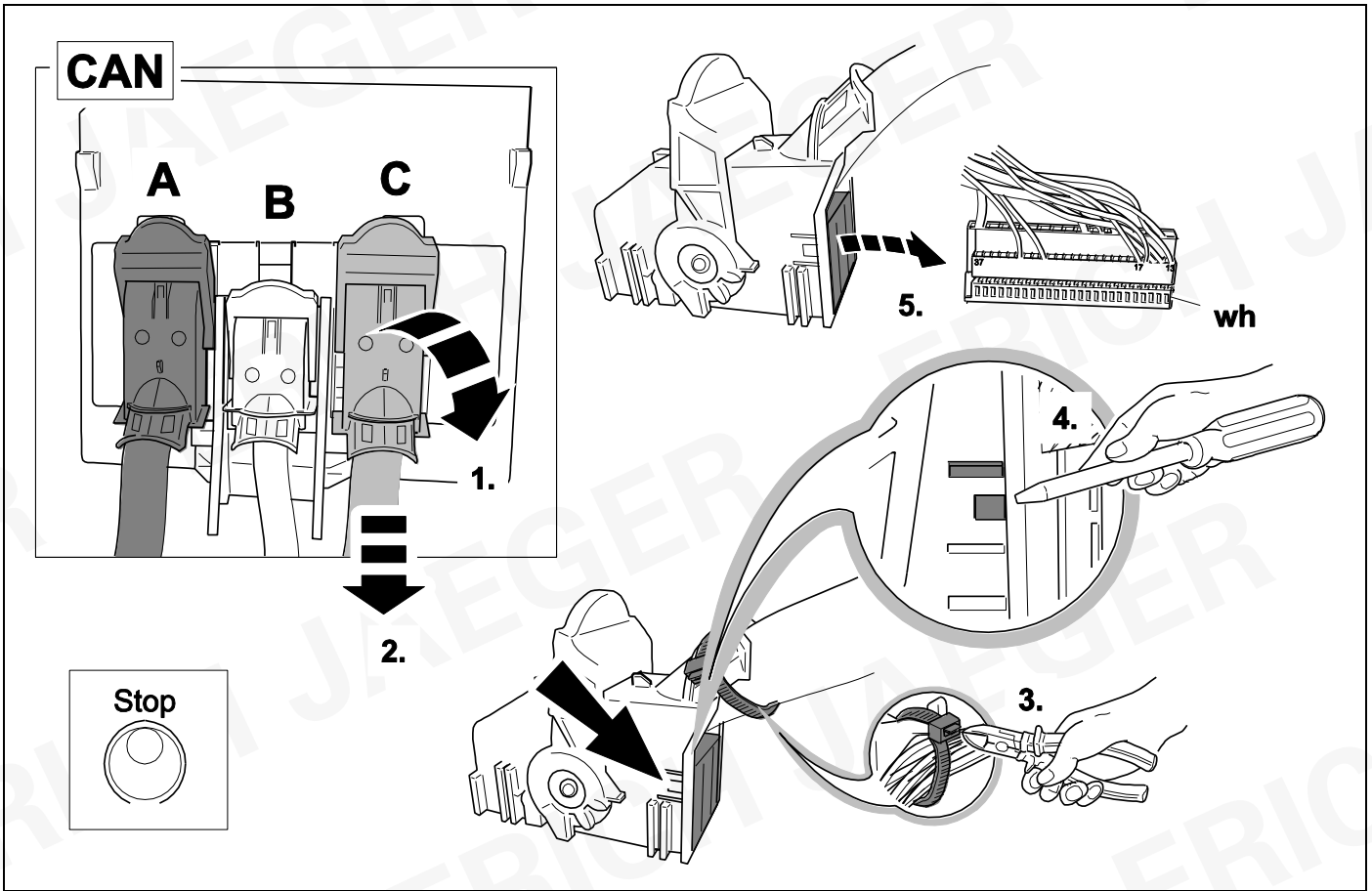

32



9

OPTION 2

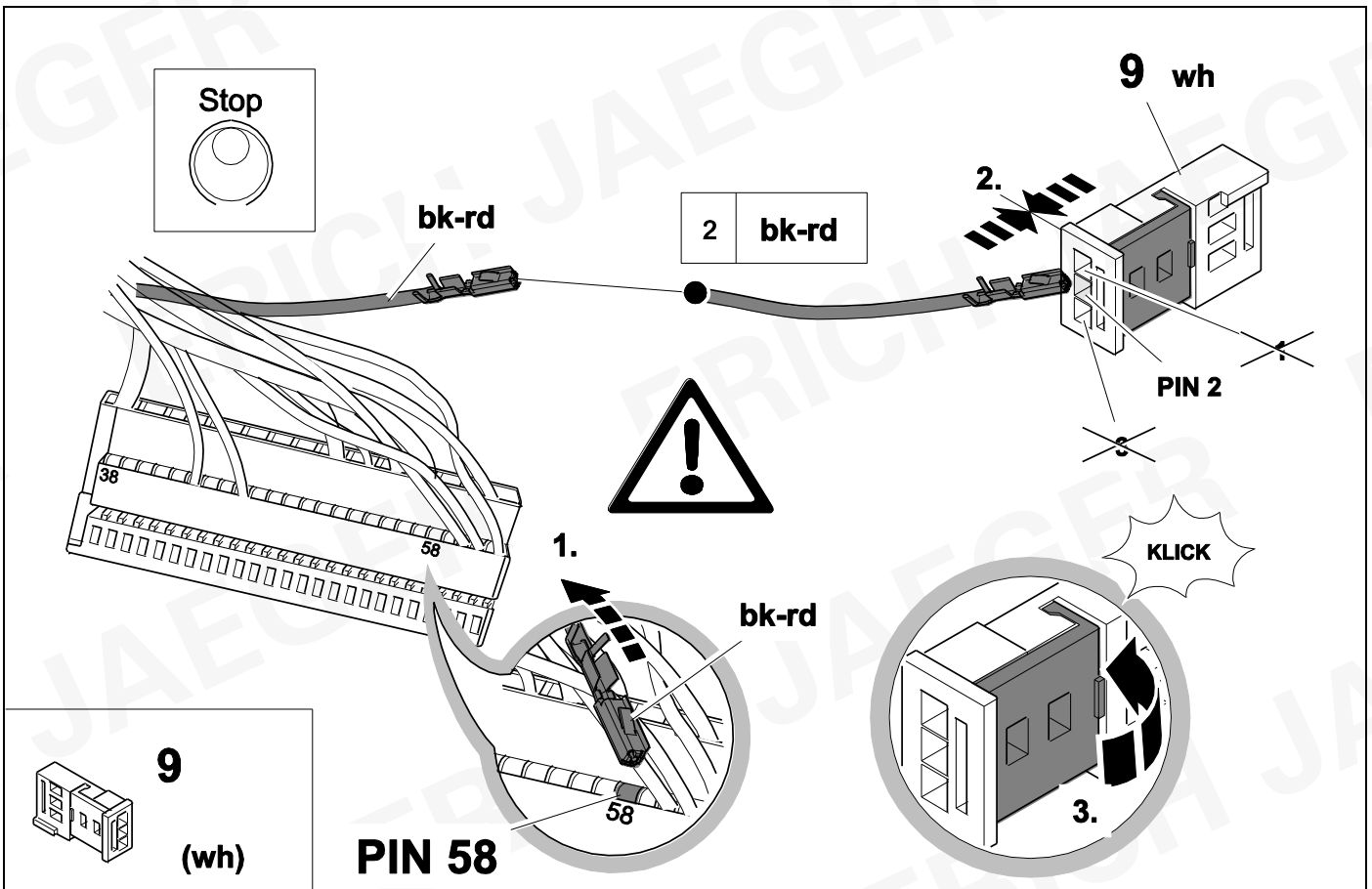

33



9

OPTION 2

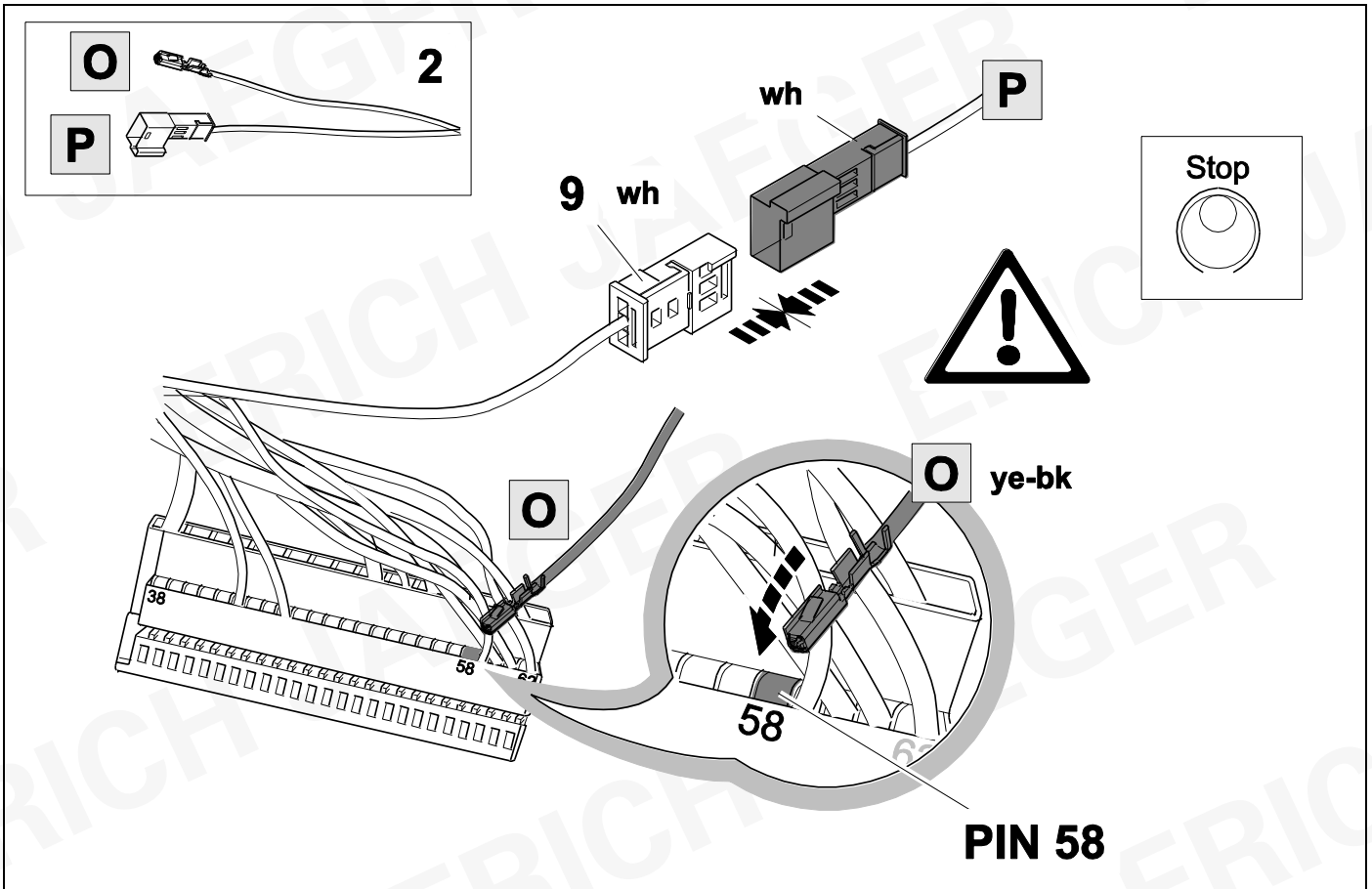

34

OPTION 2

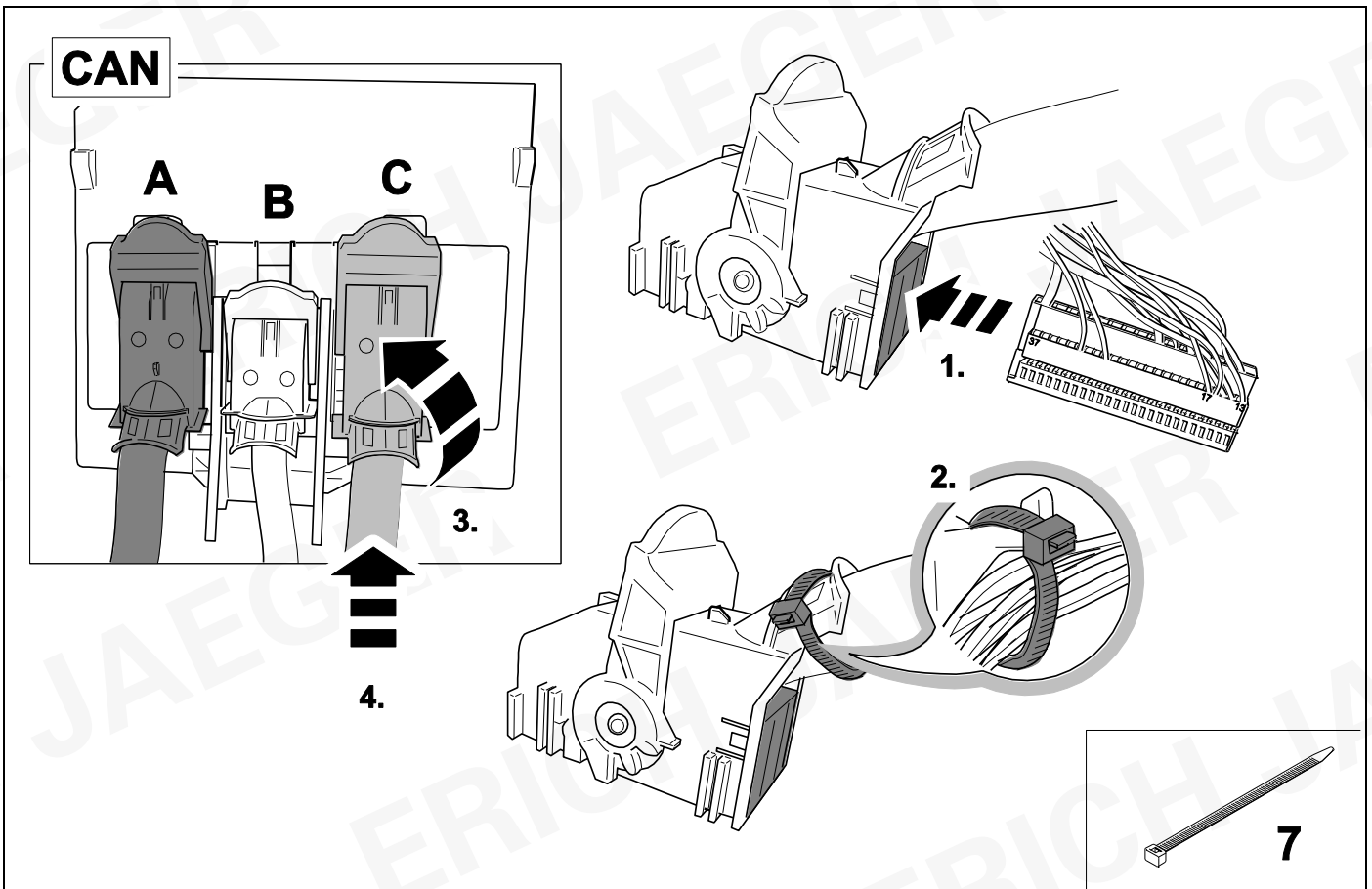

35

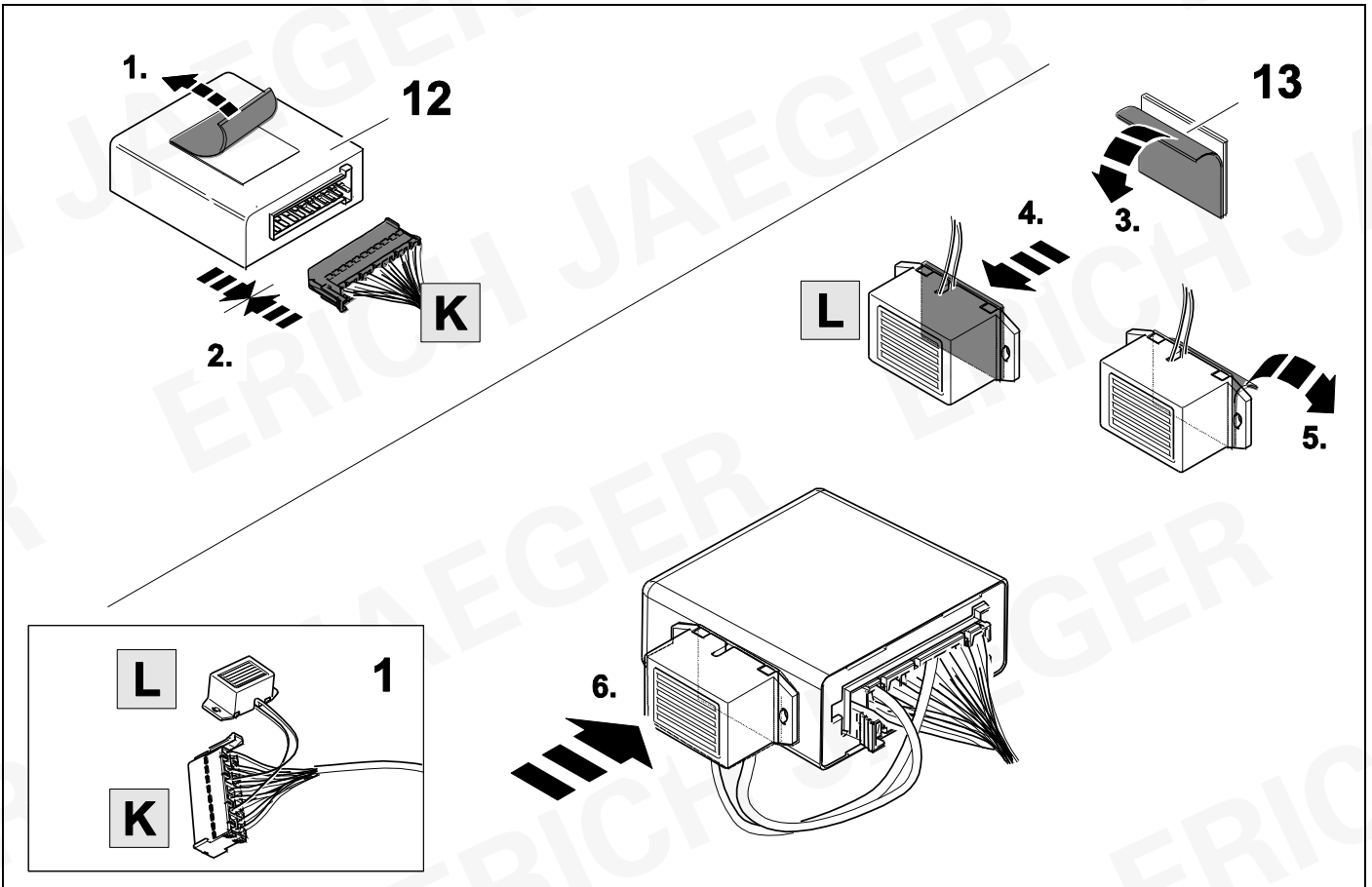

36

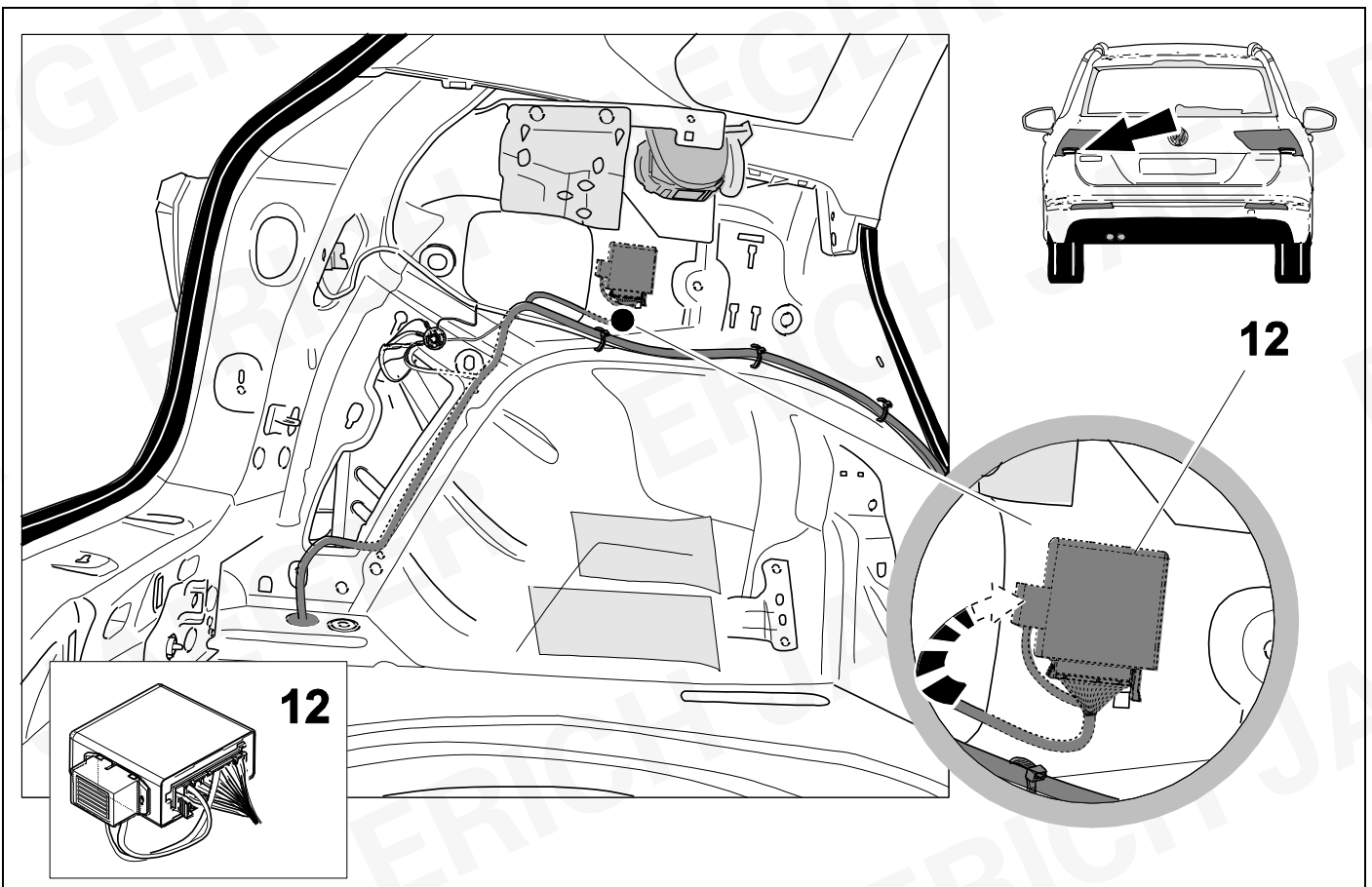

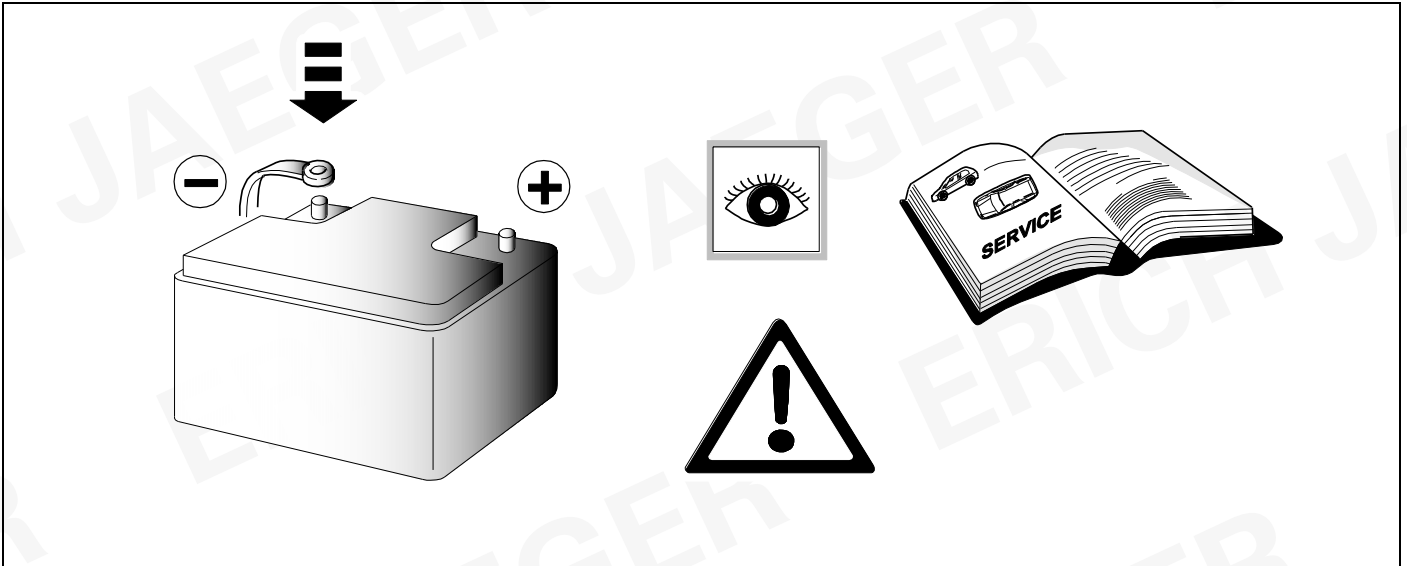

37

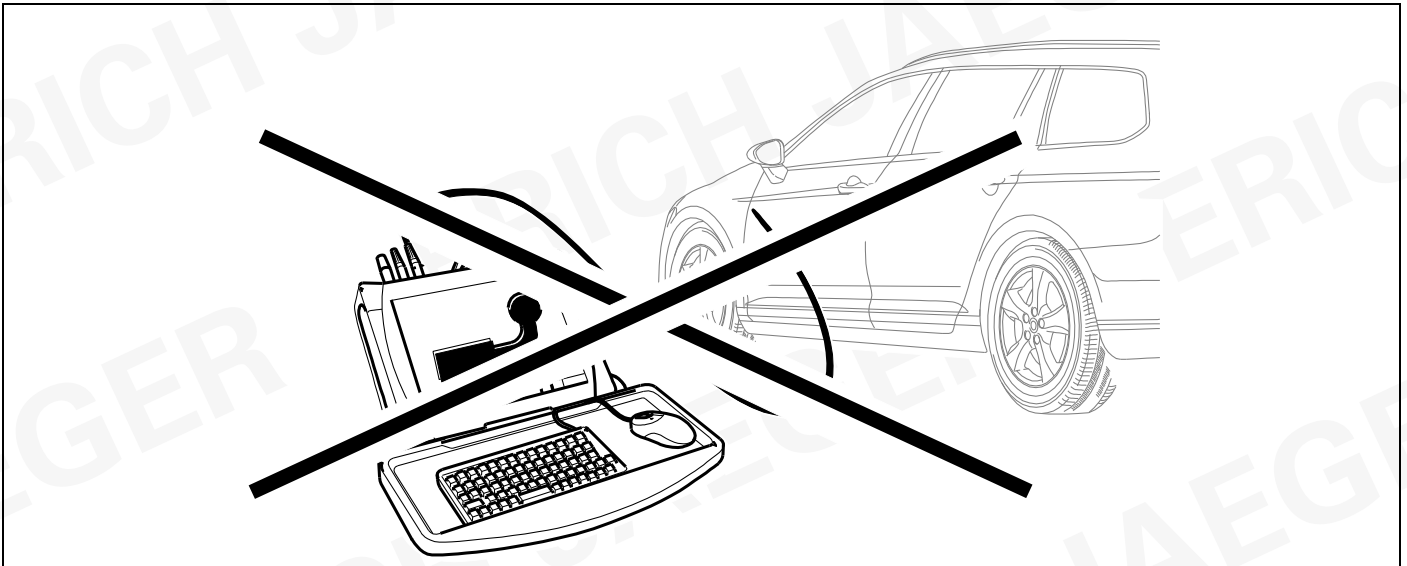

38

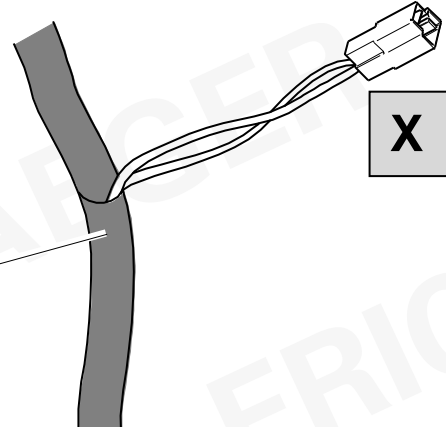
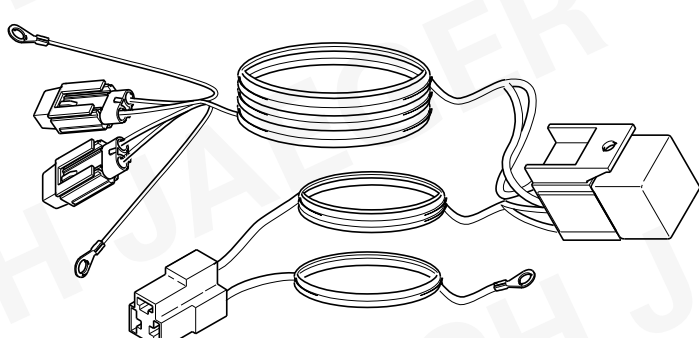

39 OPTIONAL

		ERICH JAEGER Artikelnummer: ERICH JAEGER part number:	<b>721074</b>
 <p>1</p> <p>X</p>			

## 40 CHECK

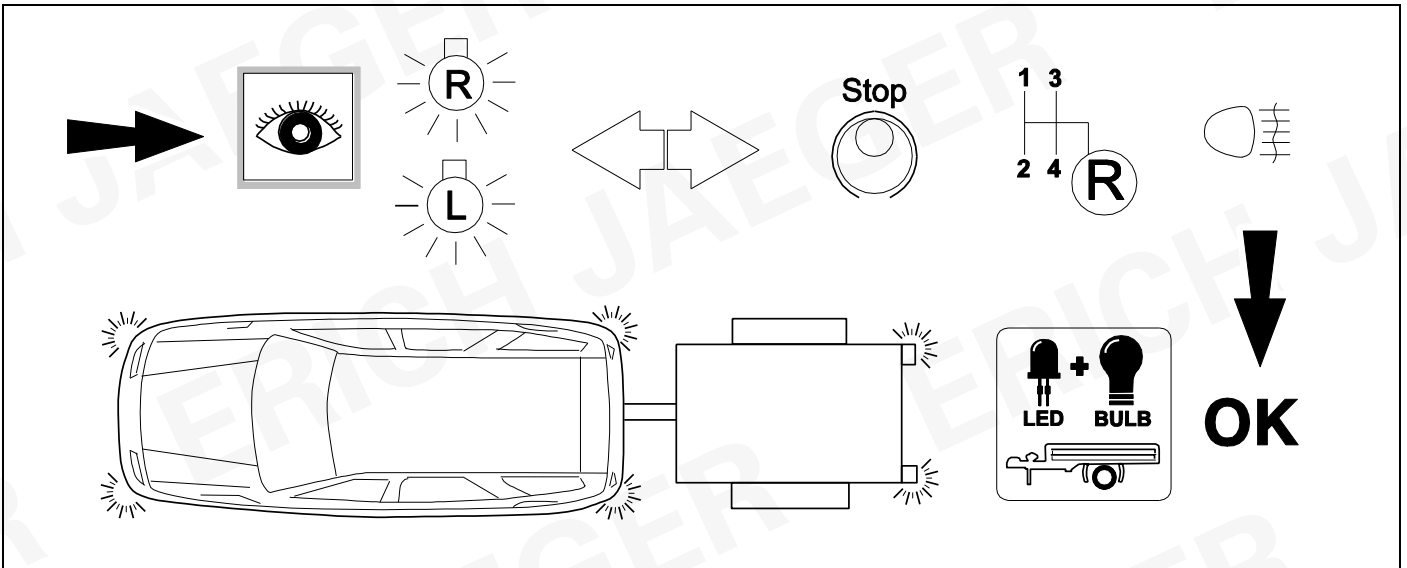

## 41 CHECK

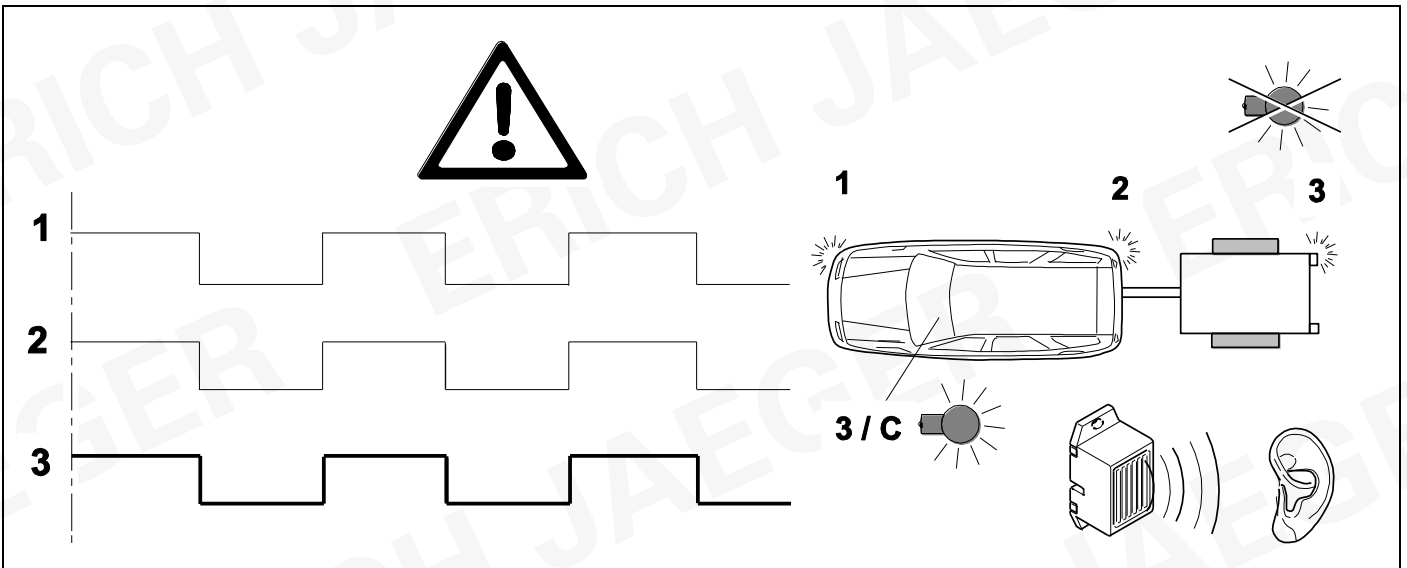

## 42 INFORMATION



**23** + **24**

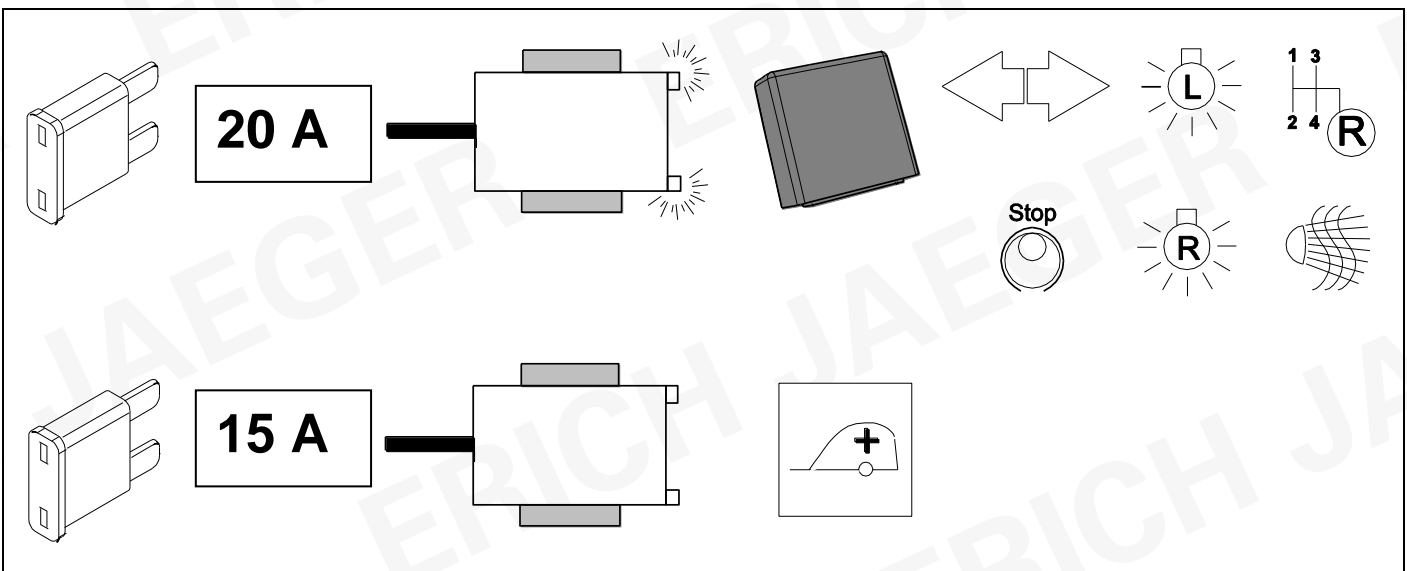



44



47

**! Achtung !**

Diese Kodierung kann eventuell nach einem Besuch bei einer autorisierten Werkstatt verloren gehen!

**! Attention !**

These codings may be lost after visiting an authorized workshop!

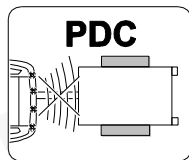

PDC

**TSP**  
Trailer  
Stability  
Program

**P**  
Trailer  
Assistent

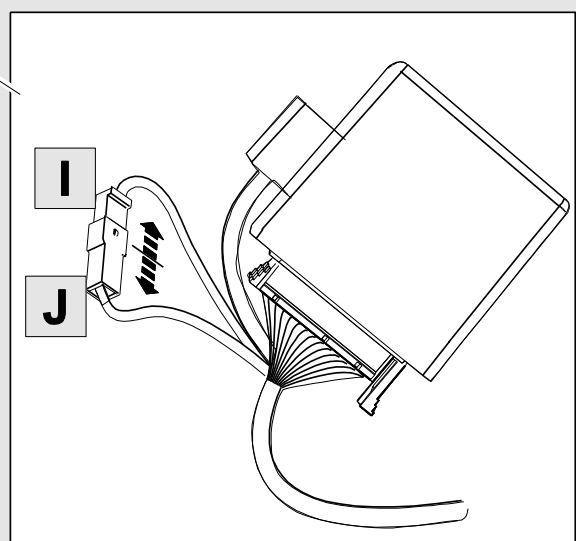
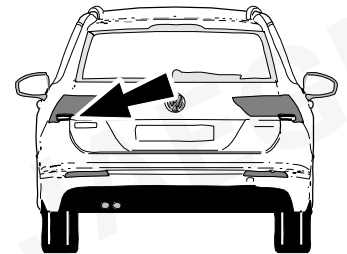
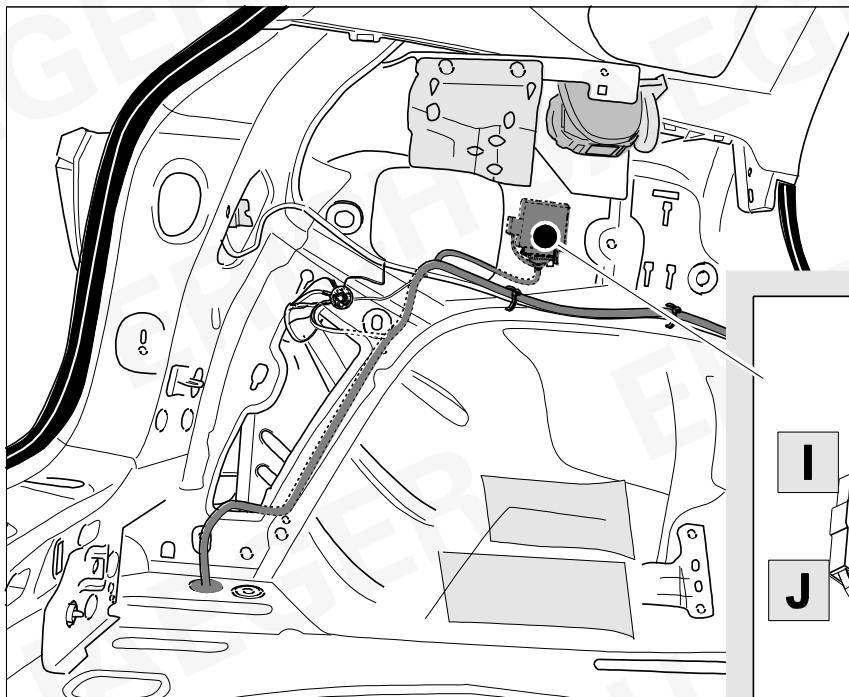

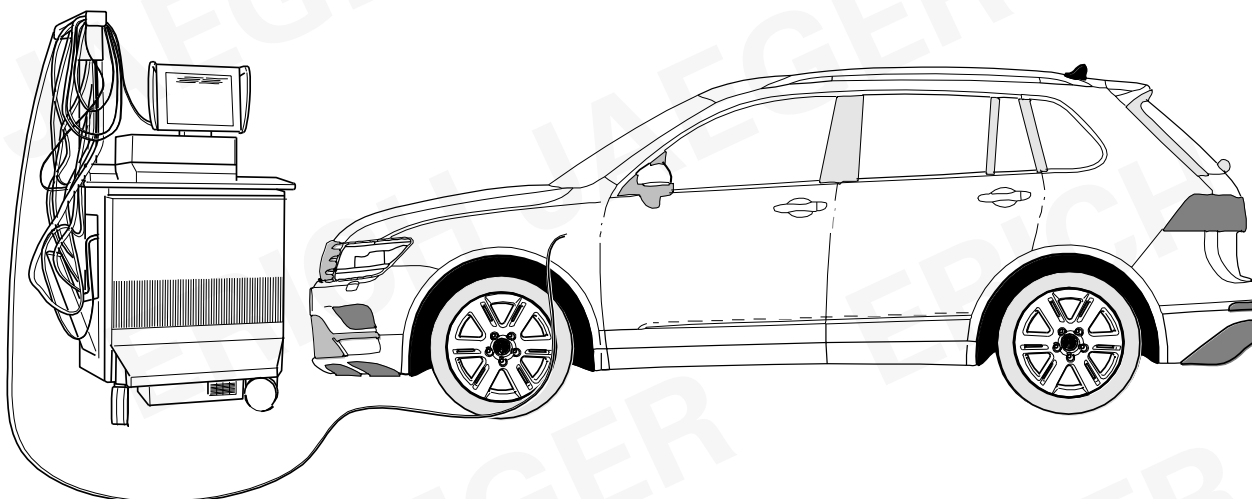

**D****Codierung bitte wie folgt durchführen:**

- Alternative Diagnosedienstleister bzw. Diagnosemethoden (lokal / offline) :
  - ODIS / VCDS
  - Hella Gutmann ( Seite 26 )
  - Autologic
  - Bosch / KTS
  - SP Diagnostic
  - SUN
  - Westfalia Auto Code
  - etc. pp.

**GB****Please effect coding as follows:**

- Alternative Diagnosis Services or diagnostic methods (local / offline) :
  - ODIS / VCDS
  - Hella Gutmann ( page 26 )
  - Autologic
  - Bosch / KTS
  - SP Diagnostic
  - SUN
  - Westfalia Auto Code
  - etc. pp.

**F****Veillez suivre le codage suivant:**

- Diagnostic services alternatives ou les méthodes de diagnostic (local/hors ligne) :
  - ODIS / VCDS
  - Hella Gutmann ( page 26 )
  - Autologic
  - Bosch / KTS
  - SP Diagnostic
  - SUN
  - Westfalia Auto Code
  - etc. pp.

**I****Favore codifica effettuate come segue:**

- -Alternativa Diagnosi Servizio o metodi diagnostici (locale/offline) :
  - ODIS / VCDS
  - Hella Gutmann ( pagina 26 )
  - Autologic
  - Bosch / KTS
  - SP Diagnostic
  - SUN
  - Westfalia Auto Code
  - etc. pp.

**E****Por favor de codificación lleva a cabo como sigue:**

- Servicio de Diagnóstico alternativa o métodos de diagnóstico (locales/fuera de linea) :
  - ODIS / VCDS
  - Hella Gutmann ( pagina 26 )
  - Autologic
  - Bosch / KTS
  - SP Diagnostic
  - SUN
  - Westfalia Auto Code
  - etc. pp.

**NL****Gelieve codering ais volgt ultgevoerd:**

- Alternatief Diagnose Dienst of diagnostische methoden (lokale/offline) :
  - ODIS / VCDS
  - Hella Gutmann ( page 26 )
  - Autologic
  - Bosch / KTS
  - SP Diagnostic
  - SUN
  - Westfalia Auto Code
  - etc. pp.

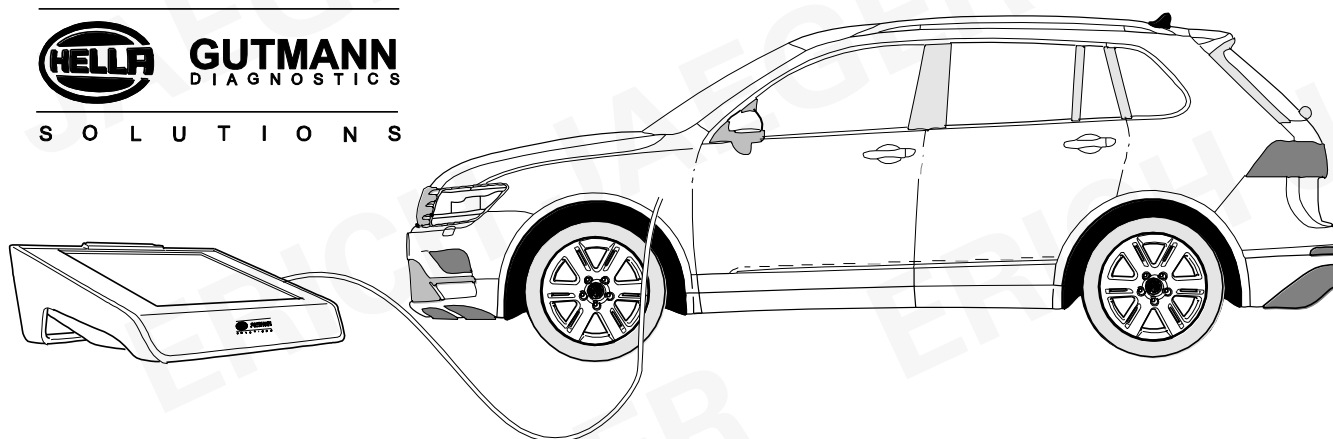

D	GB	F
<p><b>Die Aktivierung der Anhängerfunktionen muss wie folgt durchgeführt werden:</b></p> <ol style="list-style-type: none"> <li>1. Fahrzeugauswahl</li> <li>2. Zu Diagnose – Codierung wechseln</li> <li>3. Anhängerkupplung de-/aktivieren</li> <li>4. Diagnose Interface Bus auswählen</li> <li>5. Anleitung folgen</li> </ol> <p><b>Fahrzeuge mit Assistenzsystemen</b></p> <ol style="list-style-type: none"> <li>6. AHK an Assistenzsysteme anpassen ausführen</li> <li>7. Anleitung folgen</li> <li>8. Diagnose</li> <li>9. Fehlerspeicher auslesen, ggf. löschen</li> <li>10. Fertig</li> </ol>	<p><b>The activation of the trailer functions must be performed:</b></p> <ol style="list-style-type: none"> <li>1. Vehicle selection</li> <li>2. switch to diagnostics - coding</li> <li>3. Deactive/aktive trailer coupling</li> <li>4. Select diagnostic interface Bus</li> <li>5. Follow instructions</li> </ol> <p><b>Vehicle with assistance systems</b></p> <ol style="list-style-type: none"> <li>6. perform adaptation of trailer coupling on assistance systems</li> <li>7. Follow instructions</li> <li>8. Diagnostics</li> <li>9. Read out error memory, delete if necessary</li> <li>10. Done</li> </ol>	<p><b>Pour activer l'attelage, procéder de la façon suivante:</b></p> <ol style="list-style-type: none"> <li>1. Choix véhicule</li> <li>2. Aller dans le diagnostic - codage</li> <li>3. Activer/désactiver le diagnostic</li> <li>4. Sélectionner le BUS d'interface de diagnostic</li> <li>5. Suivre les instructions</li> </ol> <p><b>Véhicules avec systèmes d'aide</b></p> <ol style="list-style-type: none"> <li>6. Effectuer une adaptation d'attelage aux systèmes d'aide</li> <li>7. Suivre les instructions</li> <li>8. Diagnostic</li> <li>9. Lire la mémoire de défaut et effacer les codes d'erreur éventuellement mémorisés</li> <li>10. Terminé</li> </ol>
I	E	NL
<p><b>Per attivare le funzioni del rimorchio, procedere nel modo seguente:</b></p> <ol style="list-style-type: none"> <li>1. Scelta vettura</li> <li>2. Passare alla Diagnosi - Codifica</li> <li>3. Attivare / disattivare il gancio di traino</li> <li>4. Selezionare il interfaccia di diagnosi</li> <li>5. Seguire le istruzioni</li> </ol> <p><b>Veicoli noc suster di assistenza</b></p> <ol style="list-style-type: none"> <li>6. adattare i suster installati</li> <li>7. Seguire le istruzioni</li> <li>8. Diagnosi</li> <li>9. Leggere la memoria guasti e cancellare, se necessario</li> <li>10. Fertig</li> </ol>	<p><b>La activación de las funciones de remolque debe la siguiente manera:</b></p> <ol style="list-style-type: none"> <li>1. Selección de vehículo</li> <li>2. Cambiar a diagnosis - Codificación</li> <li>3. Desactivar/ activar acoplamiento para remolque</li> <li>4. Selecciona diagnosis Interface Bus</li> <li>5. Seguir las instrucciones</li> </ol> <p><b>En vehículos noc sistemas de asistencia</b></p> <ol style="list-style-type: none"> <li>6. Ejecutar adaptación de acoplamiento para remolque a suster de asistencia</li> <li>7. Seguir las instrucciones</li> <li>8. Diagnosi</li> <li>9. Leer memoria de averias y borrarla si es necesario</li> <li>10. Listo</li> </ol>	<p><b>De activering van de aanhangerfuncties moet als volgt worden uitgevoerd:</b></p> <ol style="list-style-type: none"> <li>1. Voertuigselectie</li> <li>2. Ga naar Diagnose - Codering</li> <li>3. Aanhangwagenkoppeling deactiveren/activeren</li> <li>4. Diagnose interface bus selecteren</li> <li>5. Volg instructie op</li> </ol> <p><b>Bij voertuigen met assistentiesystemen</b></p> <ol style="list-style-type: none"> <li>6. „Aanhangwagenkoppeling aanpassen aan assistietiesystem“ uitvoeren</li> <li>7. Volg instructie op</li> <li>8. Diagnose</li> <li>9. Foutcodegeheugen uitlezen en indien nodig wissen</li> <li>10. Gereed</li> </ol>

# 47 CHECK

# OPTION vehicle coding

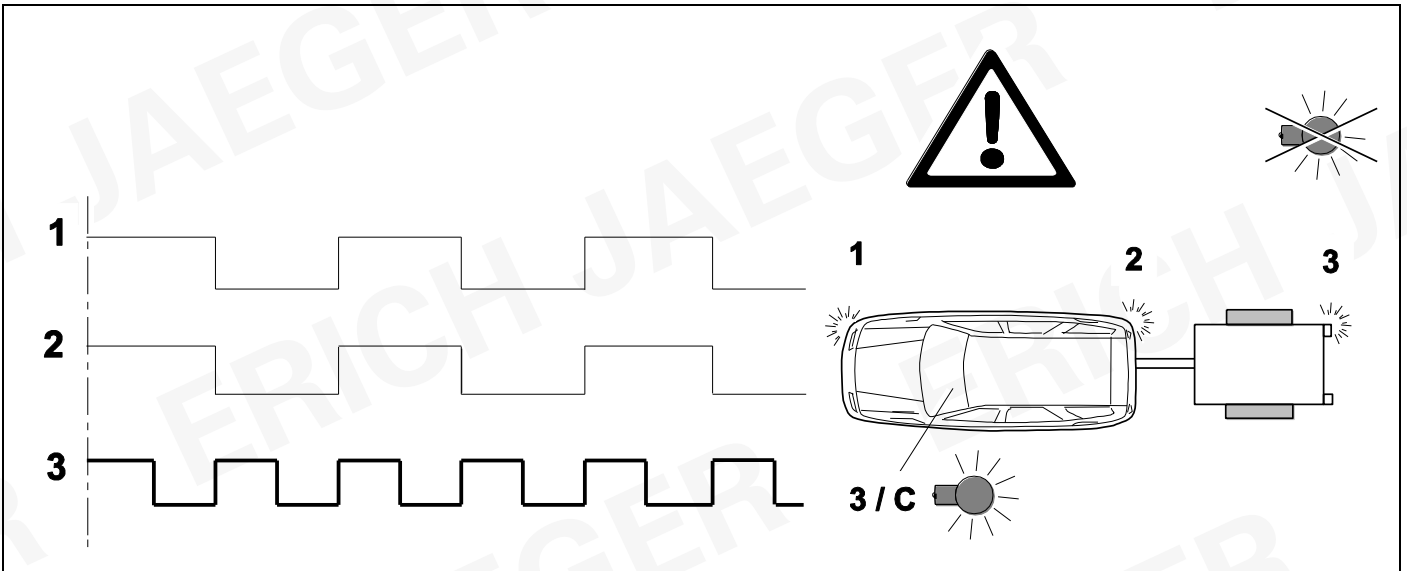

# 48

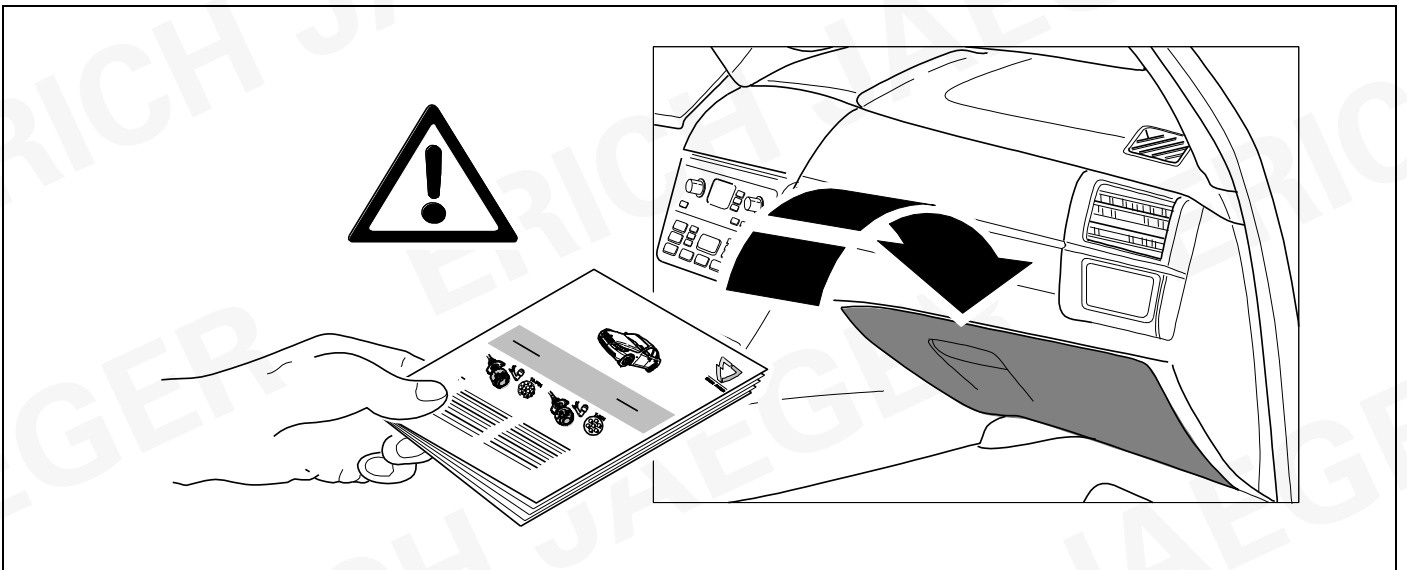

# 49

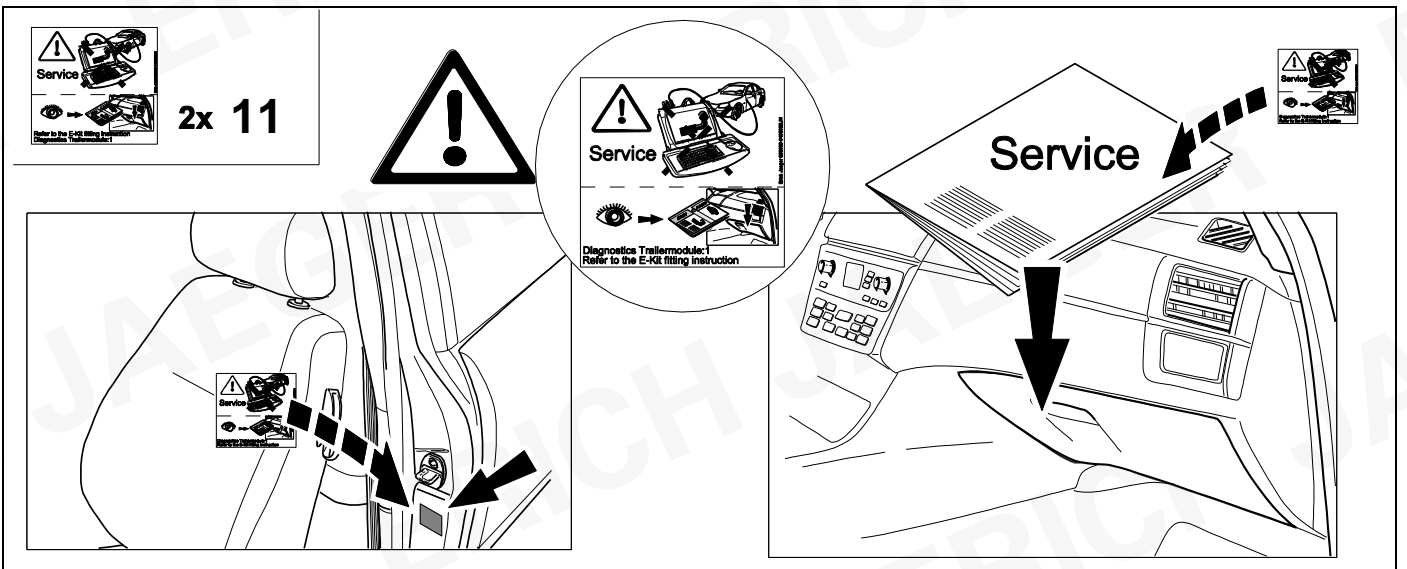

<b>D</b>	Änderungen bezüglich Konstruktion, Ausstattung Farbe sowie Irrtum vorbehalten. Angaben und Abbildungen unverbindlich	<b>PL</b>	Zastrzega się prawo do zmian dot. konstrukcji, wykończenia, kolorystyki oraz pomylek. Dane i ilustracje niewiążące.
<b>GB</b>	Subject to change in terms of construction, equipment and colour, and may contain errors. The information and illustrations are non-binding.	<b>TR</b>	Tasarım, donanım ve renk bakımından değişiklik yapma hakkı ve hata ve eksiklik mahfuzdur. Veriler ve resimler bağlayıcı değildir.
<b>F</b>	Sous réserve de modifications de la construction, de l'équipement, de la couleur et sous réserve d'erreurs. Les indications et les illustrations sont sans engagement.	<b>H</b>	A szerkezet, a kivétel és a szín változtatása, valamint a változások joga fenntartva. Az adatok és az ábrák nem kötelező érvényűek.
<b>NL</b>	Wijzigingen met betrekking tot constructie, uitvoering en kleur evenals vergissingen voorbehouden. Gegevens en afbeeldingen niet bindend.	<b>HR</b>	Pravo promjena u svezi konstrukcije, opreme, boje kao i zabune oridžavamo. Podaci i ilustracije su neobavezne.
<b>DK</b>	Ændringer med hensyn til konstruktion, udstyr, farver samt fejl forbeholdes. Oplysninger og illustrationer er uforpligtende.	<b>BUL</b>	Запазени права по отношение на конструкцията, обзавеждането, цвета и грешки. Данните и изображенията не са обвързващи.
<b>N</b>	Ændringer angående konstruksjon, utstyr, farge og feiltagelse forbeholdes. Oplysninger og illustrasjoner uforbindtlig.	<b>RO</b>	Ne rezervăm dreptul unor modificări ale construcției, dotării, culorii și dreptul la erori Datele indicate și imaginile sunt orientative.
<b>S</b>	Med reservation för ändringar vad det gäller konstruktion, utrustning, färg samt för misstag. Uppgifterna och bilderna är inte bindande.	<b>RU</b>	Права на внесение изменений относительно конструкции, оснащения, окраски, а также на ошибки сохраняются. Данные и иллюстрации имеют примерный характер.
<b>FIN</b>	Pidätämme oikeuden rakennetta, varustusta, väriä koskeviin sekä erehdyksestä johtuviin muutoksiin. Tiedot ja kuvat eivät ole sitovia.	<b>LT</b>	Pasiliekaama konstrukcijos, įrangos bei reikmenų, spalvos pakeitimų ir klaidų teisė. Duomenys ir iliustracijos neįpareigojantys.
<b>I</b>	Con riserva di modifiche relative a progettazione, dotazione, colore ed errori. Le indicazioni e figure sono fornite senza impegno.	<b>LV</b>	Tiek paturētas tiesības uz konstrukcijas, iekārtu, krāsu izmaiņām, kā arī kļūdīšanās. Dati un attēli bez saistībām.
<b>E</b>	Reservadas las modificaciones respecto a diseño, equipamiento, color, así como error. Indicaciones y figuras sin compromiso.	<b>EST</b>	Konstruktsooni, varustuse ja vœrvi osas muudatused ning eksimine lubatud. Andmed ja joonised on mittesiduvad.
<b>P</b>	Reservamos o direito de alterações relativamente ao desenho, equipamento, cor, bem como de erro. Os dados e as gravuras não implicam compromisso da nossa parte.	<b>SLO</b>	Zadržana pravica do sprememb glede konstrukcije, opreme, barve ter pomote. Podatki in slike so neobvezne.
<b>GR</b>	Διατηρώνουμε κάθε επιφύλαξη ως προς αλλαγές σε σχέση με κατασκευή, εξοπλισμό, διαρρύθμιση, χρωματισμούς και λάθη παραδρομής.	<b>SK</b>	Zmeny, ktoré sa týkajú konštrukcie, vybavenia, farby, ako aj omyly sú vyhradené. Údaje a zobrazenia sú nezáväzné.
<b>CZ</b>	Změny, týkající se konstrukce, vybavení, barvy, jakož i omyly jsou vyhrazeny. Údaje a vyobrazení jsou nezávazné.		

**ERICH JAEGER Artikelnummer:**  
**ERICH JAEGER part number:**

**311069**

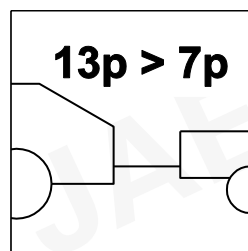
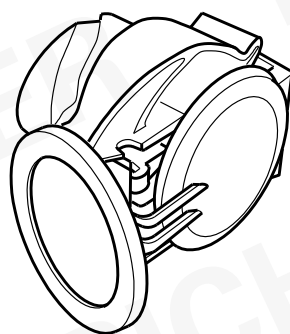

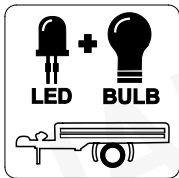

**Jaeger FLEX  
2in1**

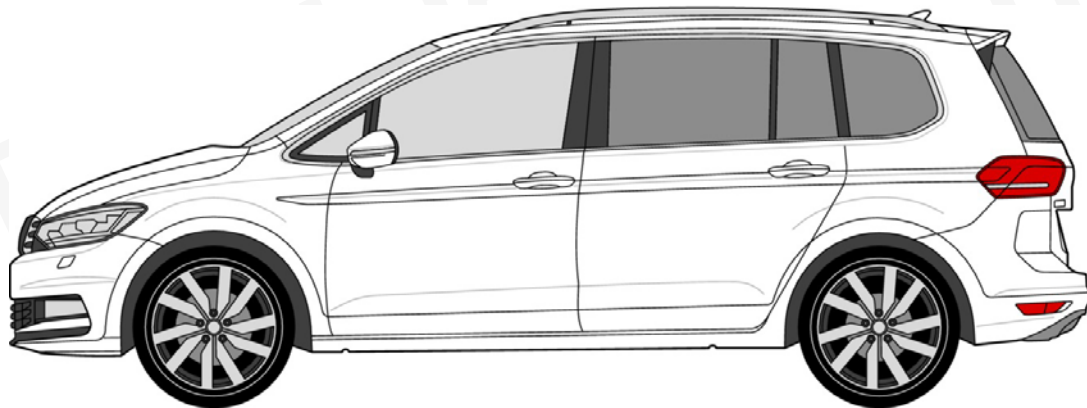

**VW Touran**

**08/15 >>**

**748343**

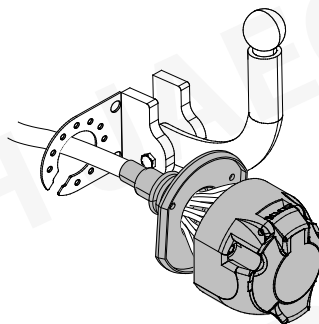

**13-PIN**

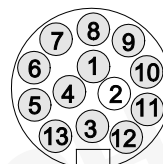

**ISO 11446**

- |  |   |
|--|---|
| <b>(D)</b> Einbauanleitung             | <b>(PL)</b> Instrukcja montażu                |
| <b>(GB)</b> Installation instructions  | <b>(TR)</b> Montaj talimatı                   |
| <b>(F)</b> Consignes de montage        | <b>(H)</b> Beépítési útmutató                 |
| <b>(NL)</b> Montagehandleiding         | <b>(HR)</b> Upute o ugradnji                  |
| <b>(DK)</b> Montagevejledning          | <b>(BUL)</b> Инструкция за монтаж             |
| <b>(N)</b> Monteringsinstruksjon       | <b>(RO)</b> Instrucțiuni de montaj            |
| <b>(S)</b> Installationsanvisning      | <b>(RU)</b> Инструкция по монтажу и установке |
| <b>(FIN)</b> Asennusohje               | <b>(LT)</b> Montavimo informacija             |
| <b>(I)</b> Istruzioni per il montaggio | <b>(LV)</b> Iemontēšanas pamācība             |
| <b>(E)</b> Instrucciones de montaje    | <b>(EST)</b> Paigaldusjuhend                  |
| <b>(P)</b> Instruções de montagem      | <b>(SLO)</b> Navodilo za vgradnjo             |
| <b>(GR)</b> Οδηγίες εγκατάστασης       | <b>(SK)</b> Montážny návod                    |
| <b>(CZ)</b> Návod k montáži            |   |



# KIT

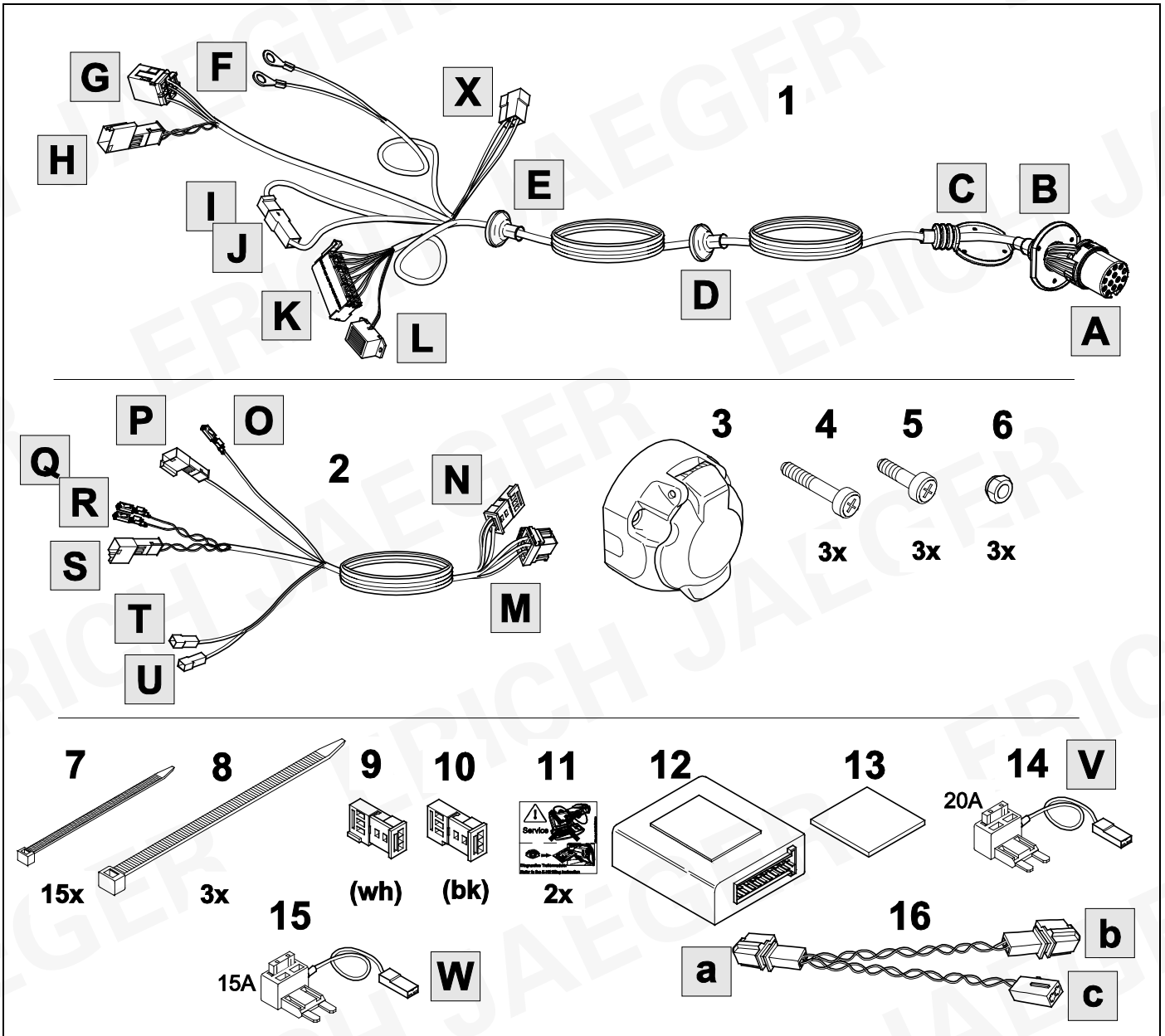

# TOOLS

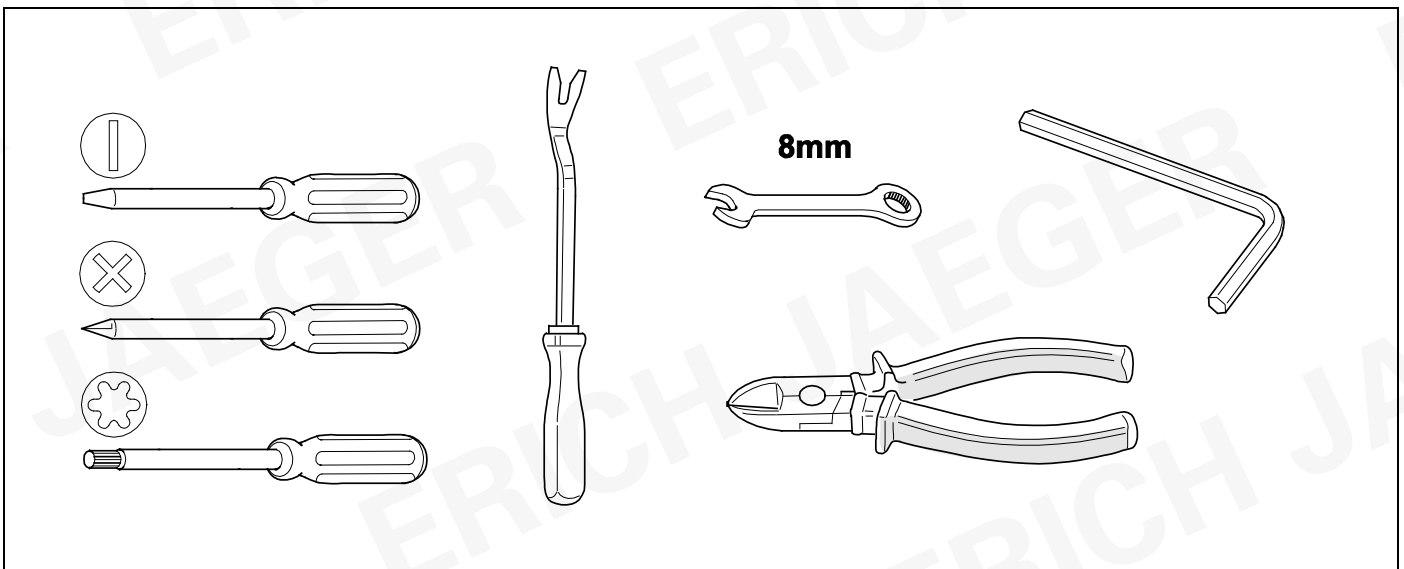

1

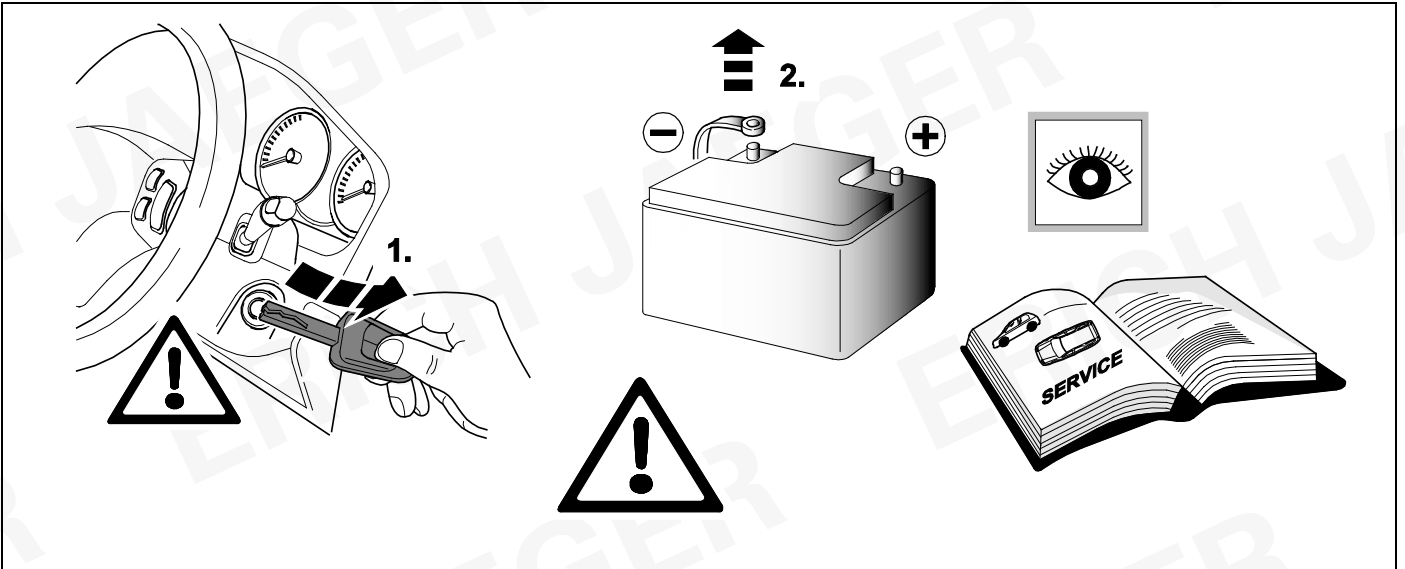

## 2 REMOVE

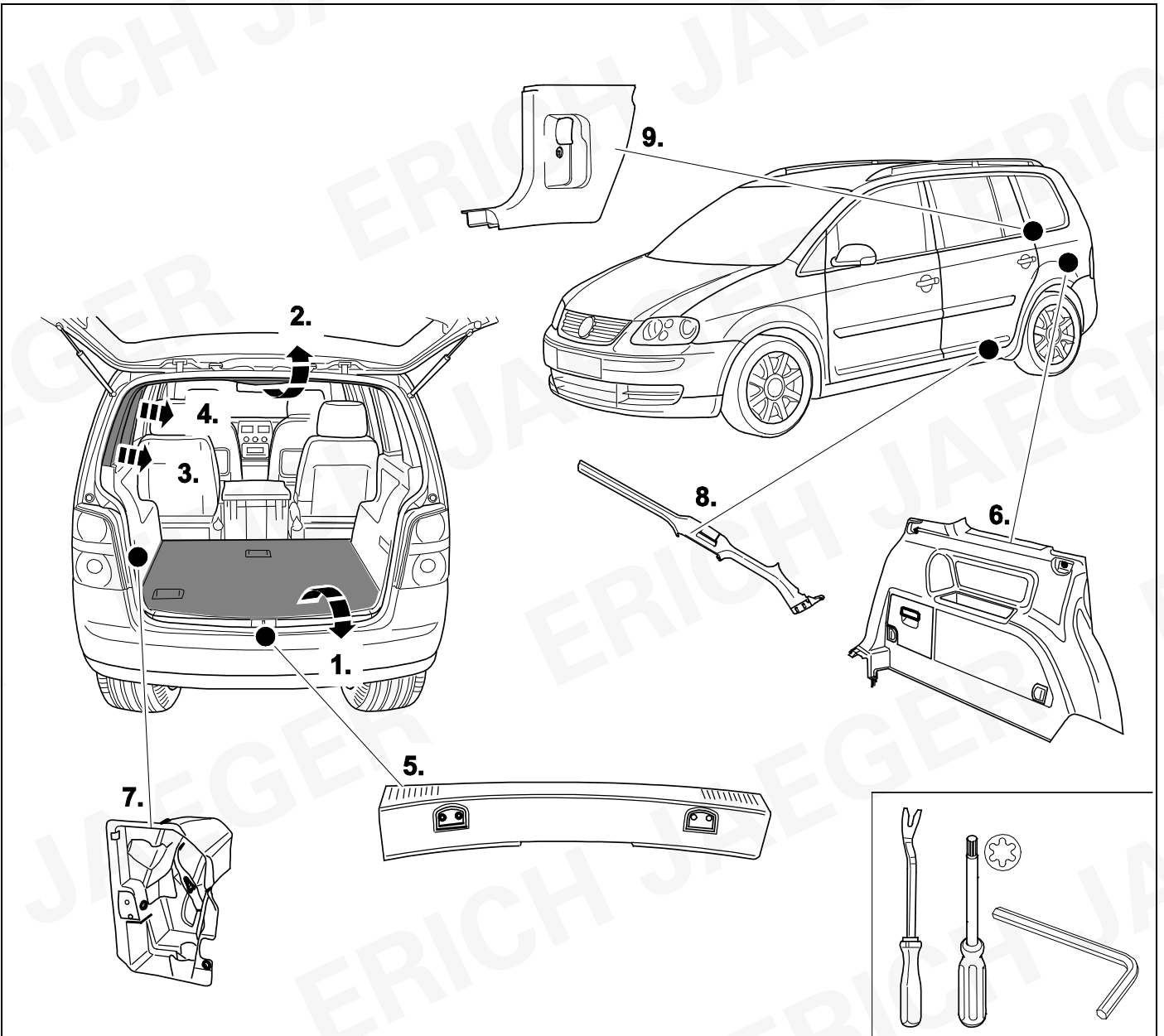

3

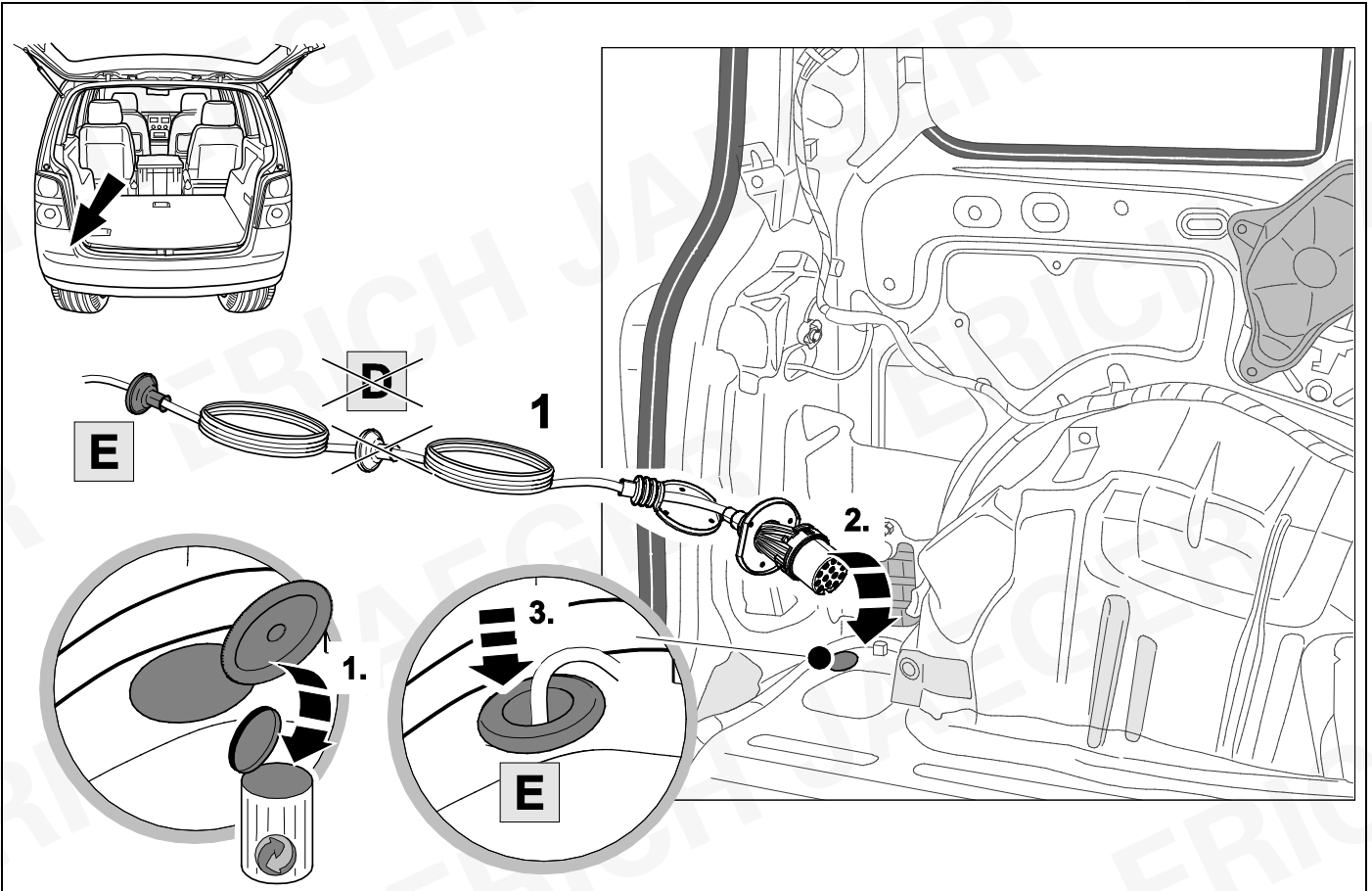

4

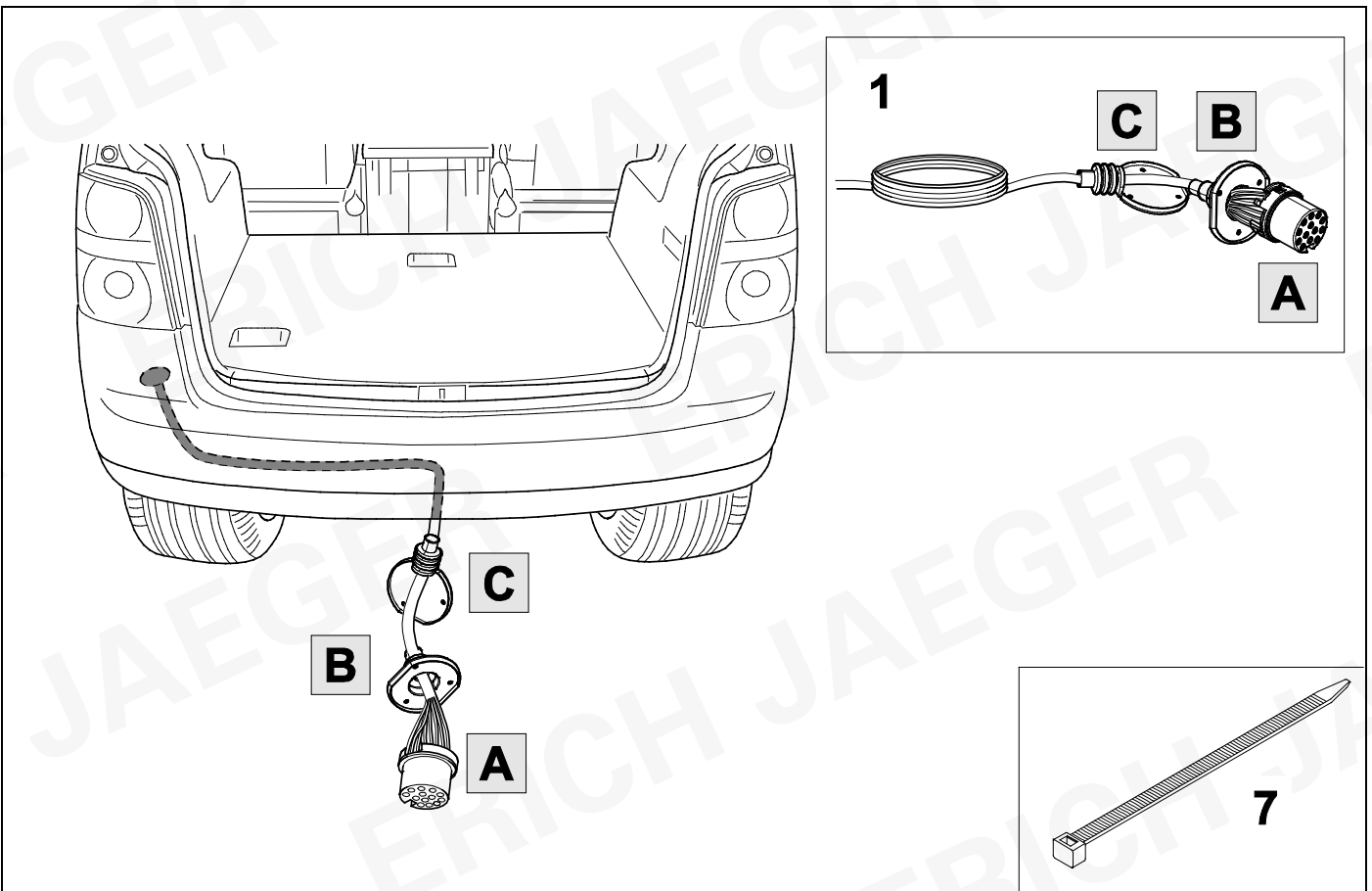



5

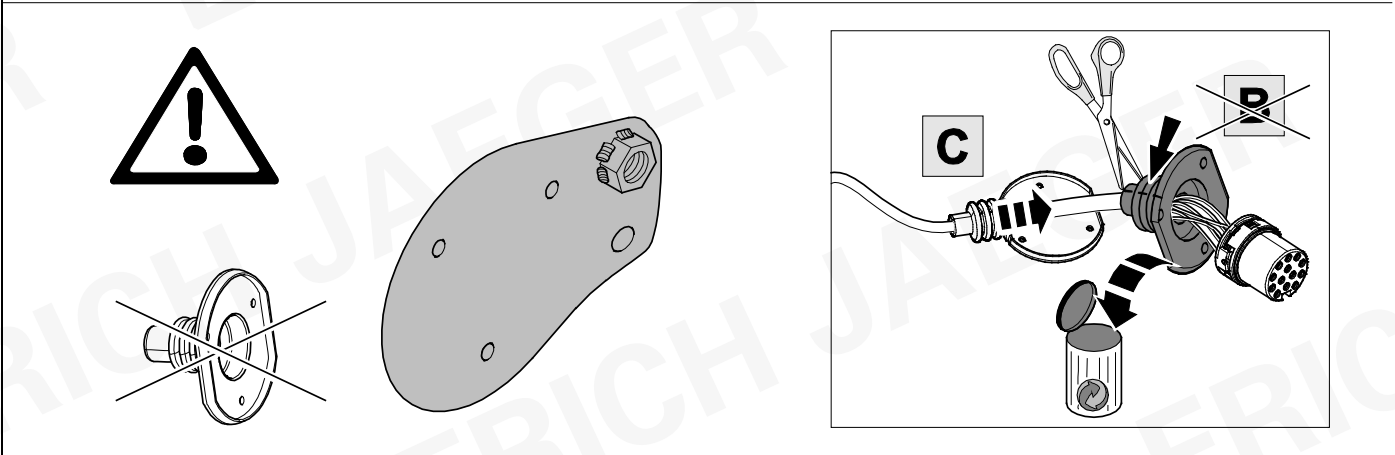
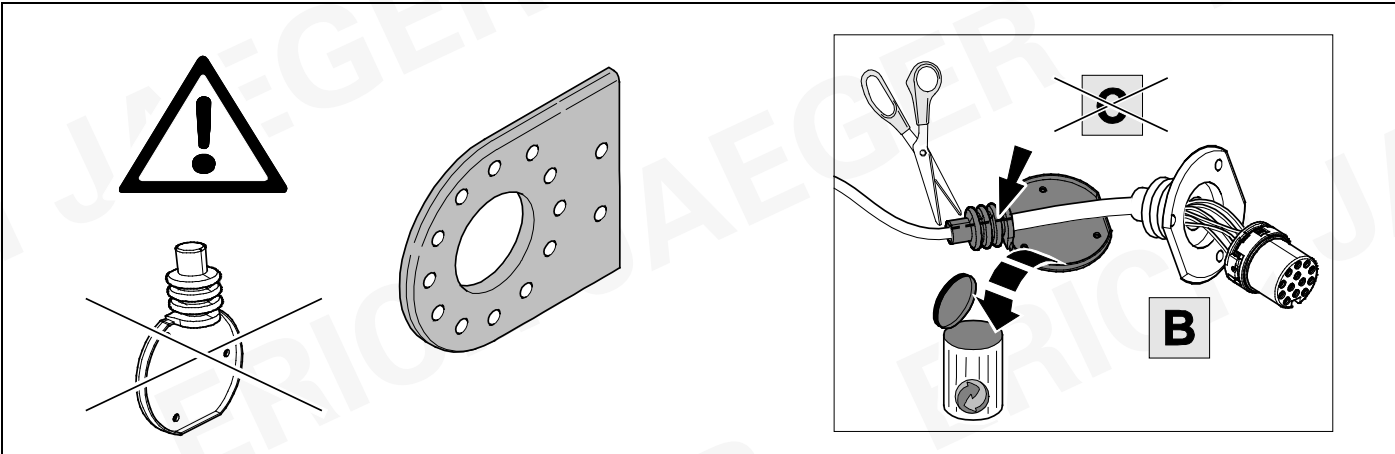

6



8

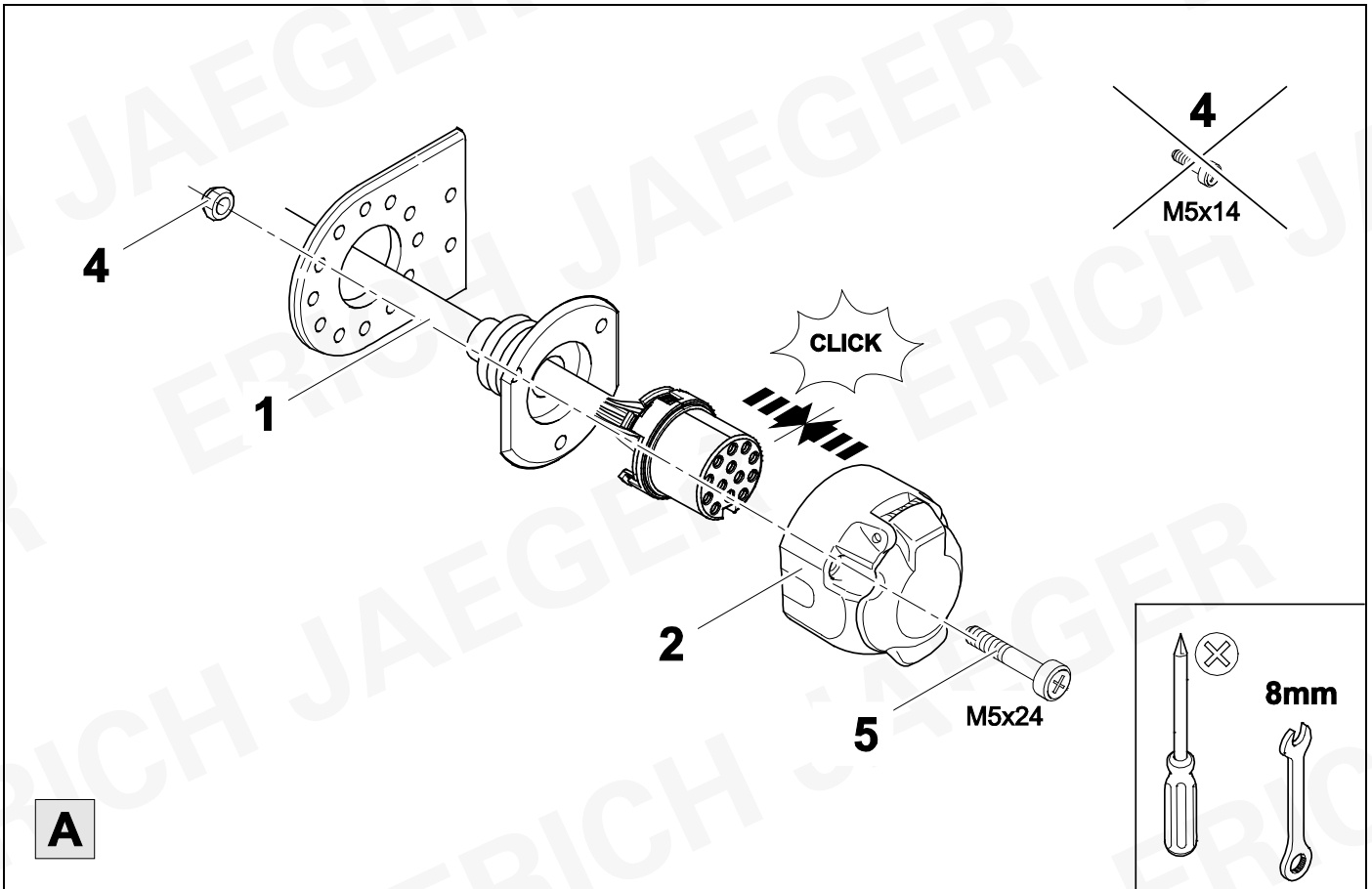

7



8

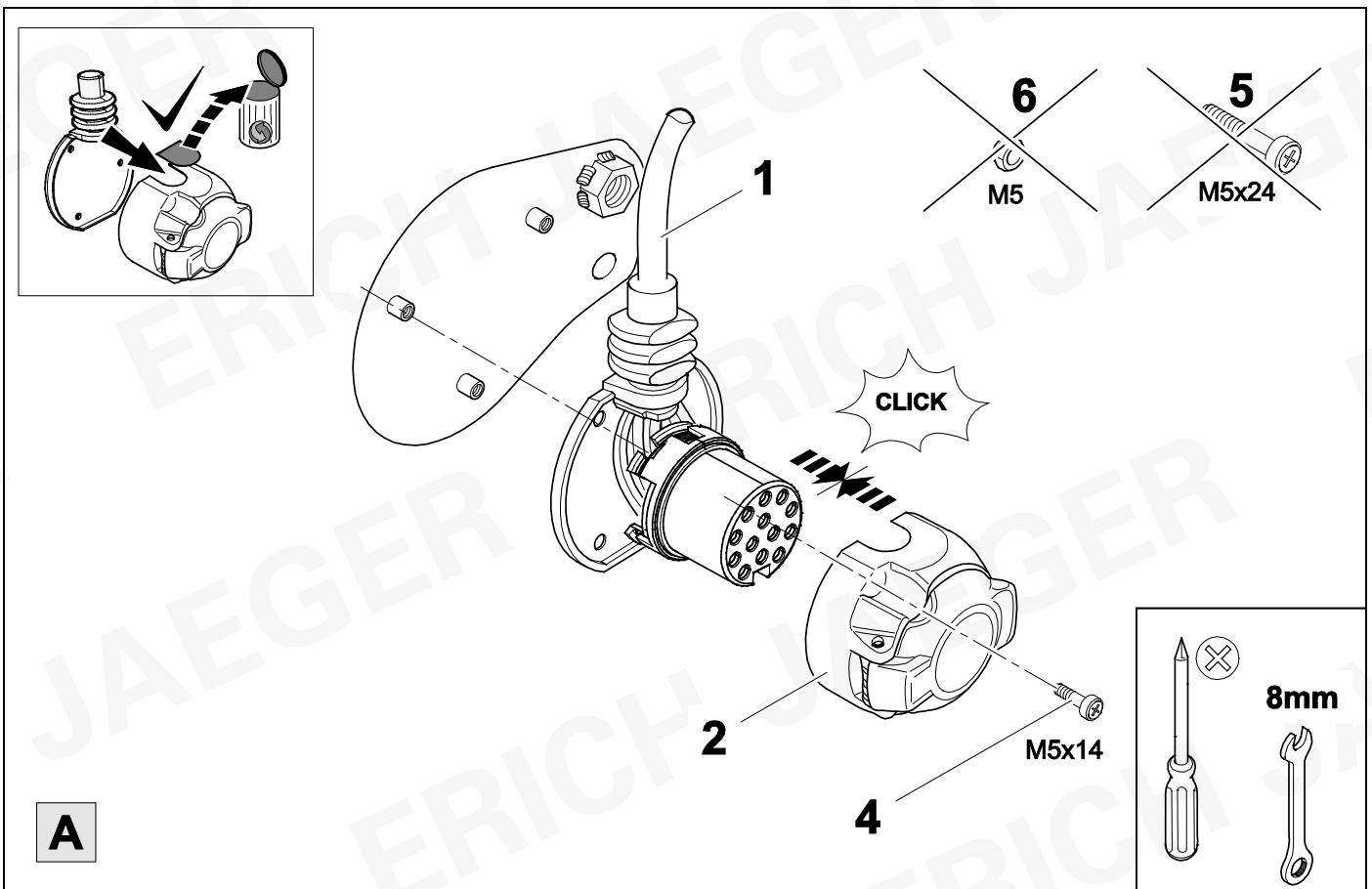

8



9

1	bk/wh		8	bu/rd	
2	gy		9	rd/bu	
3	wh/bn		10	ye	
4	bk/gn		11	bn/gn	
5	gy/rd		12	no	
6	bk/rd		13	bn	
7	gy/bk				

9	bk	wh	gy	gn	rd	bu	ye	bn	pu	or	no
---	----	----	----	----	----	----	----	----	----	----	----

<b>(D)</b>	schwarz	weiß	grau	grün	rot	blau	gelb	braun	violett	orange	nicht belegt
<b>(GB)</b>	black	white	grey	green	red	blue	yellow	brown	purple	orange	not occupied
<b>(F)</b>	noir	blanc	gris	vert	rouge	bleu	jaune	brun	violet	orange	inutilisé
<b>(NL)</b>	zwart	wit	grijs	groen	rood	blauw	geel	bruin	violet	oranje	niet aangesloten
<b>(DK)</b>	sort	hvid	grå	grøn	rød	blå	gul	brun	violet	orange	ikke anvendt
<b>(N)</b>	svart	hvit	grå	grønn	rød	blå	gul	brun	fiolett	oransje	ikke i bruk
<b>(S)</b>	svart	vit	grå	grön	röd	blå	gul	brun	violett	orange	ej använd
<b>(FIN)</b>	musta	valkoinen	harmaa	vihreä	punainen	sininen	keltainen	ruskea	violetti	oranssi	ei varattu
<b>(I)</b>	nero	bianco	grigio	verde	rosso	blu	giallo	marrone	viola	arancione	libero
<b>(E)</b>	negro	blanco	gris	verde	rojo	azul	amarillo	marrón	violeta	anaranja-do	no ocupado
<b>(P)</b>	preto	branco	cinzento	verde	vermelho	azul	amarelo	castanho	violeta	laranja	não ocupado
<b>(GR)</b>	μαύρος	λευκός	Γκρι	πράσινος	κόκκινος	μπλε	κίτρινος	καφέ	Μωβ	πορτοκαλί	δεν είναι κατ'επιτημένως
<b>(PL)</b>	czarny	biały	szary	zielony	czerwony	niebiesko	żółty	brazowy	fioletowy	pomarańczowy	wolny
<b>(CZ)</b>	černý	bílý	šedý	zelený	červený	modrý	žlutý	hnědý	fialový	oranžový	neobsazen
<b>(TR)</b>	siyah	beyaz	gri	yeşil	kırmızı	mavi	sarı	kahverengi	mor	portakal rengi	boş
<b>(H)</b>	fekete	fehér	szürke	zöld	piros	kék	sárga	barna	ibolyakék	narancssárga	nem foglalt
<b>(HR)</b>	crno	bijelo	sivo	zeleno	crveno	plavo	zuto	smeđe	ljubičasto	narandžasto	nije zauzeto
<b>(BUL)</b>	черен	бял	сив	зелен	червен	син	жълт	кафяв	виолетов	оранжев	свободно
<b>(RO)</b>	negru	alb	gri	verde	roșu	albastru	galben	maro	violet	portocaliu	liber
<b>(RU)</b>	черный	белый	серый	зеленый	красный	голубой	жёлтый	коричневый	пурпурный	оранжевый	свободно
<b>(LT)</b>	juoda	balta	pilka	žalia	raudona	mėlyna	geltona	ruda	purpurinė	oranžinė	laisva
<b>(LV)</b>	melna	balta	pelēka	zaļa	sarkana	zila	dzeltena	brūna	purpur-sarkana	oranža	brīvs
<b>(EST)</b>	must	valge	hall	roheline	punane	sinine	kollane	pruun	purpur-punane	oraanž	vaba
<b>(SLO)</b>	črna	bela	siva	zelena	rdeča	modra	rumena	smeđ	vijoličast	oranžen	ni zasedeno
<b>(SK)</b>	čierny	biely	šedý	zelený	červený	modrý	žltý	hnědý	fialový	pomaraňový	neobsadený

10

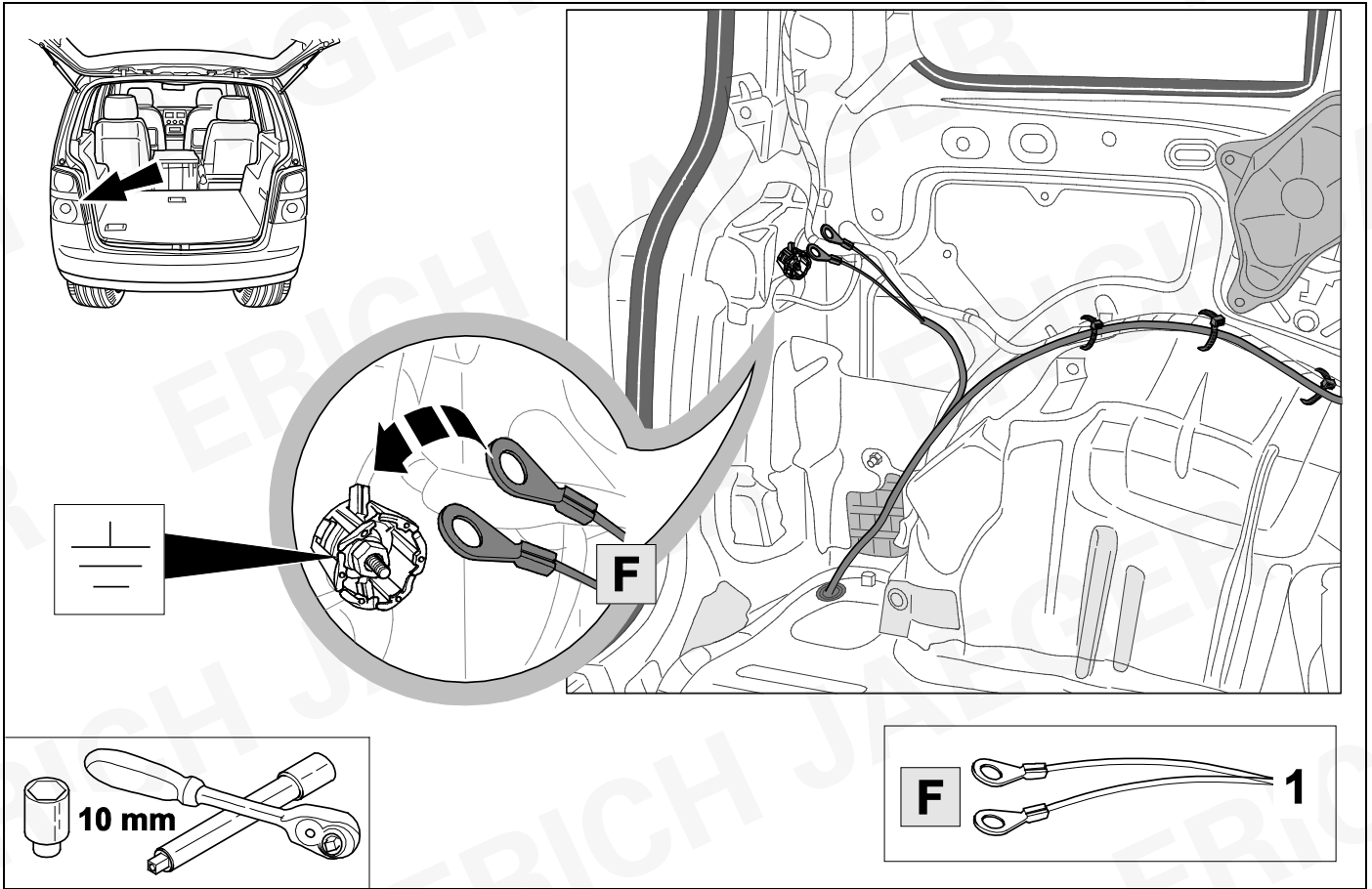

11

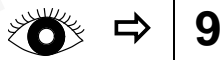

**Fahrzeuge mit Anhängervorbereitung**  
**Vehicles with trailer preparation**

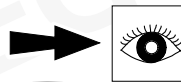
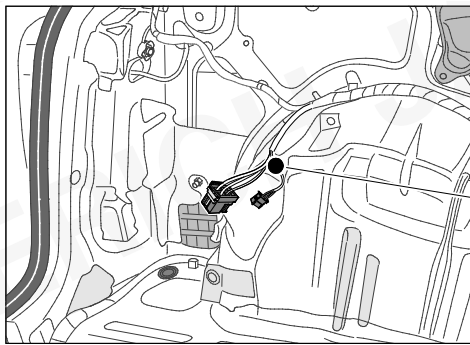

**OPTION 1**

12 ⇒ 19

35 ⇒ 49

**Fahrzeuge ohne Anhängervorbereitung**  
**Vehicles without trailer preparation**

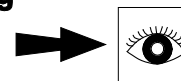
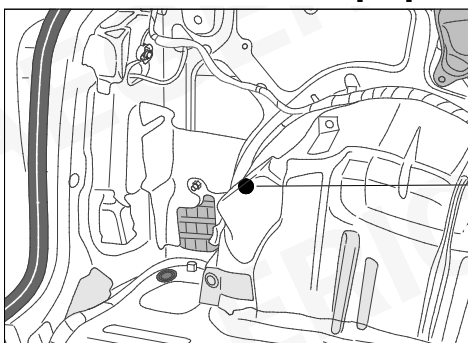

**OPTION 2**

20 ⇒ 49

12



9

OPTION 1

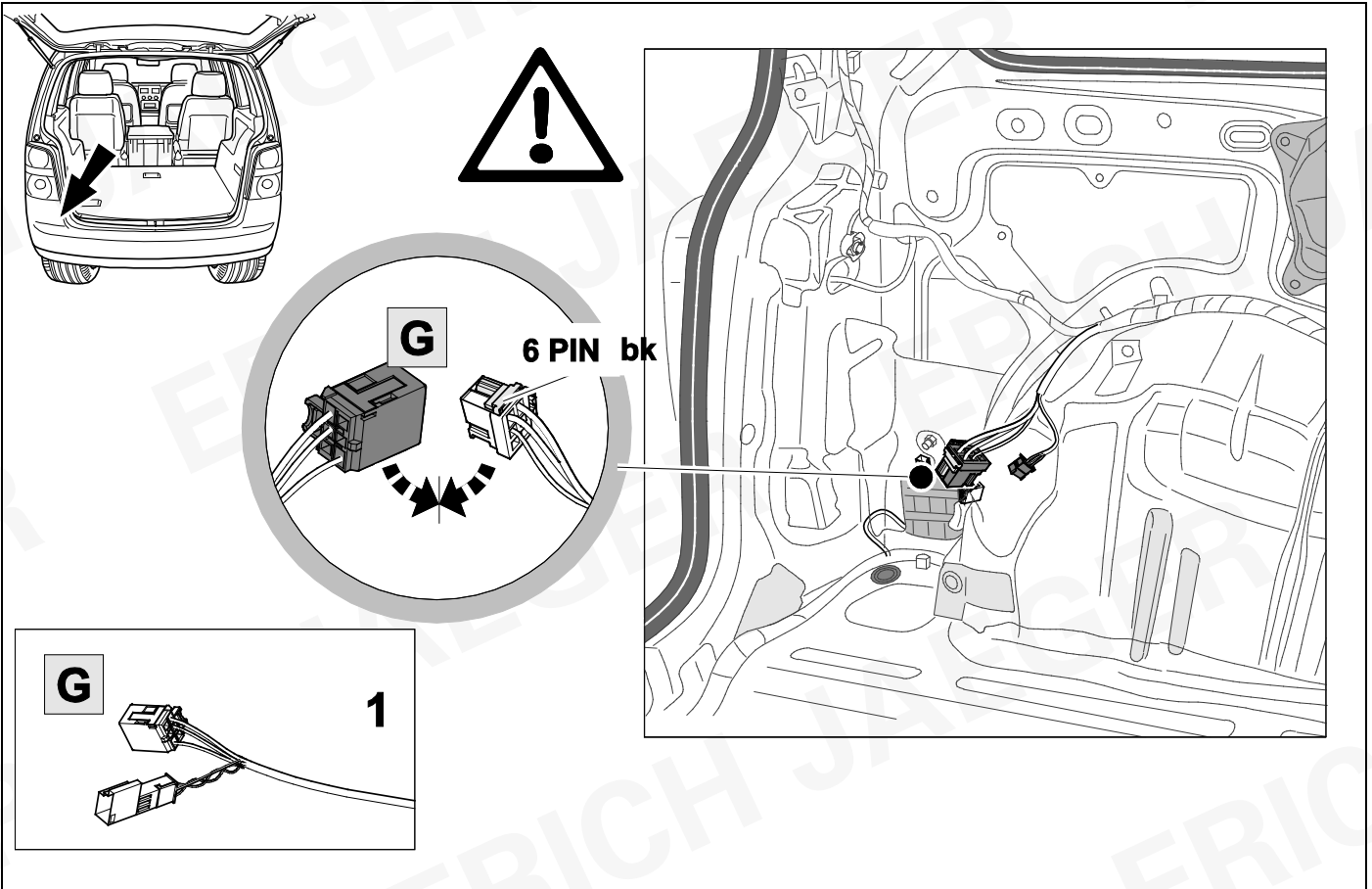

13



9

OPTION 1

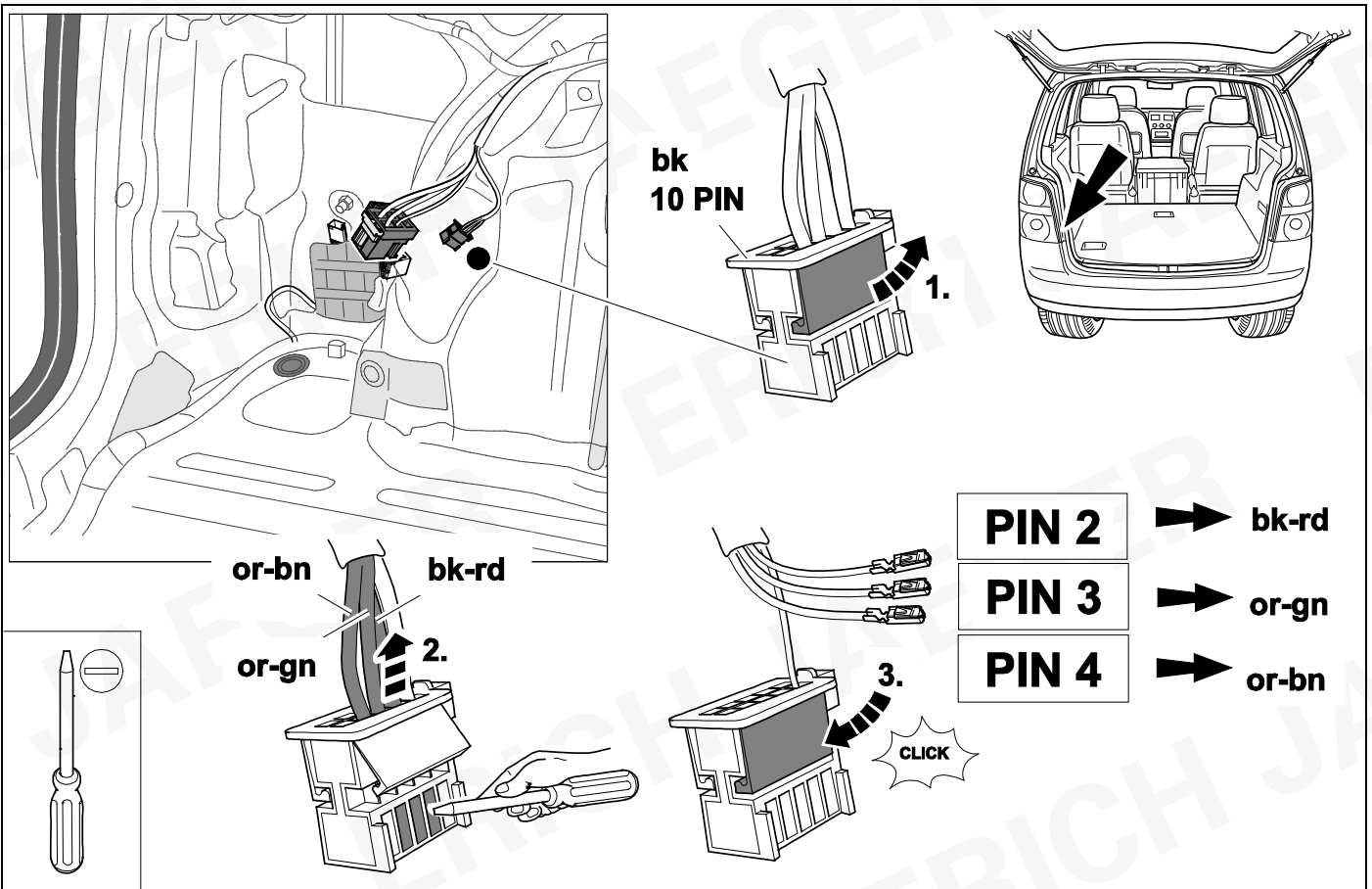

14



9

OPTION 1

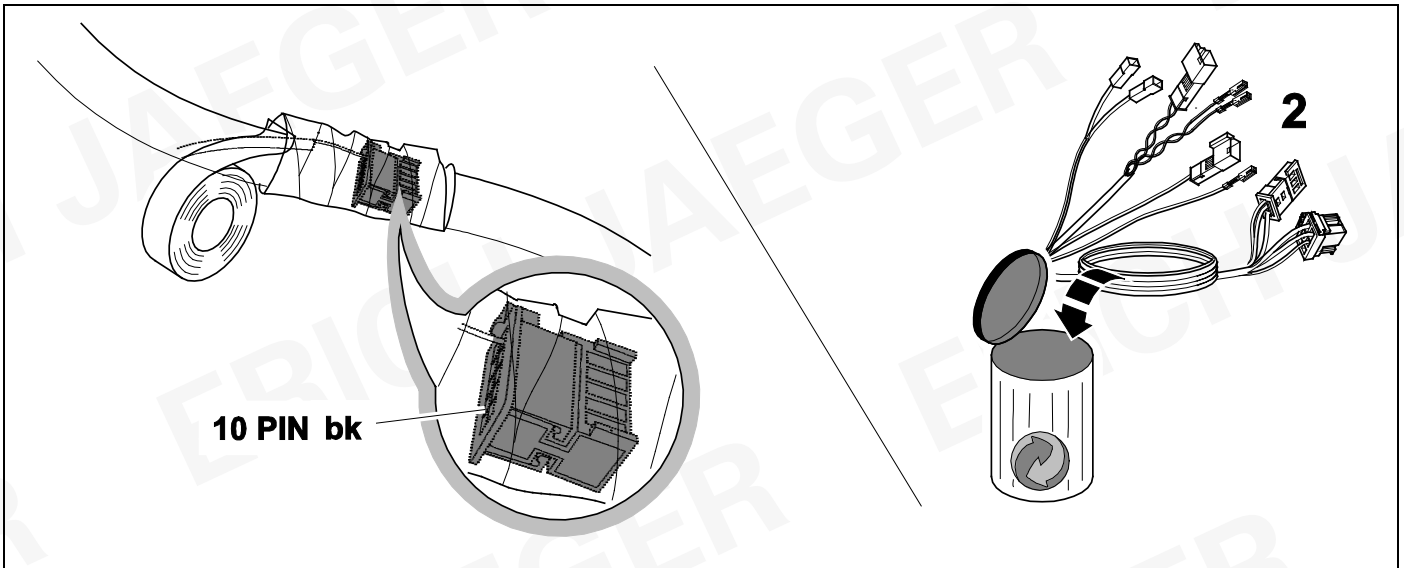

15



9

OPTION 1

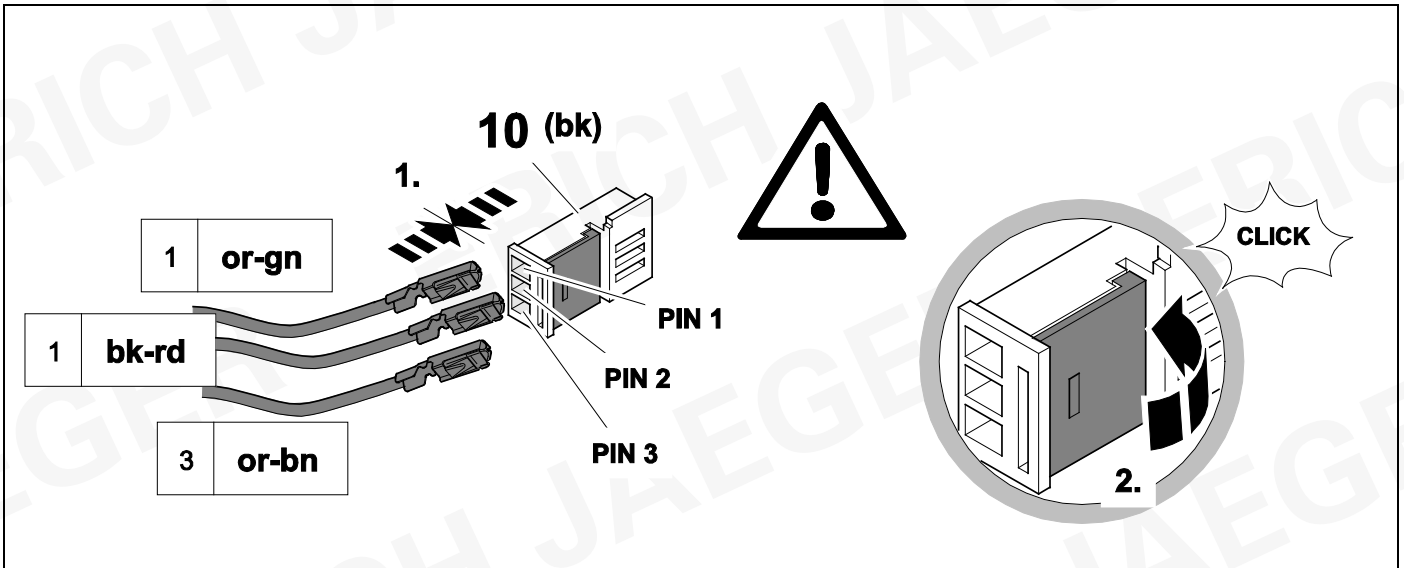

16



9

OPTION 1

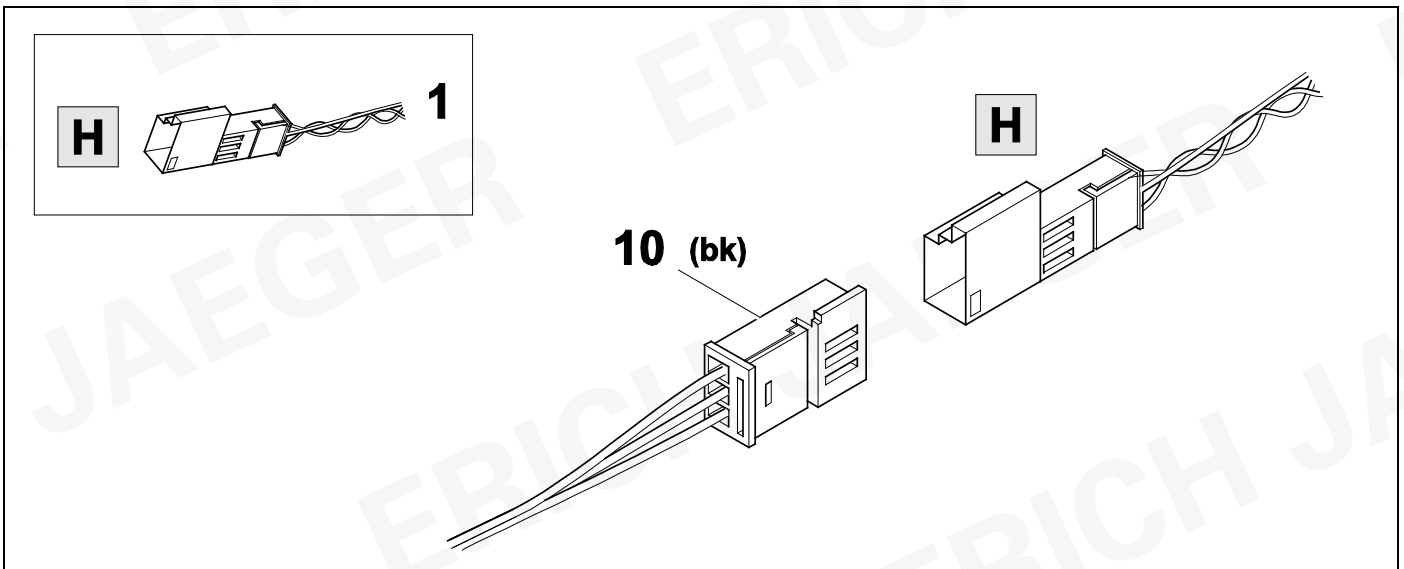

17

OPTION 1

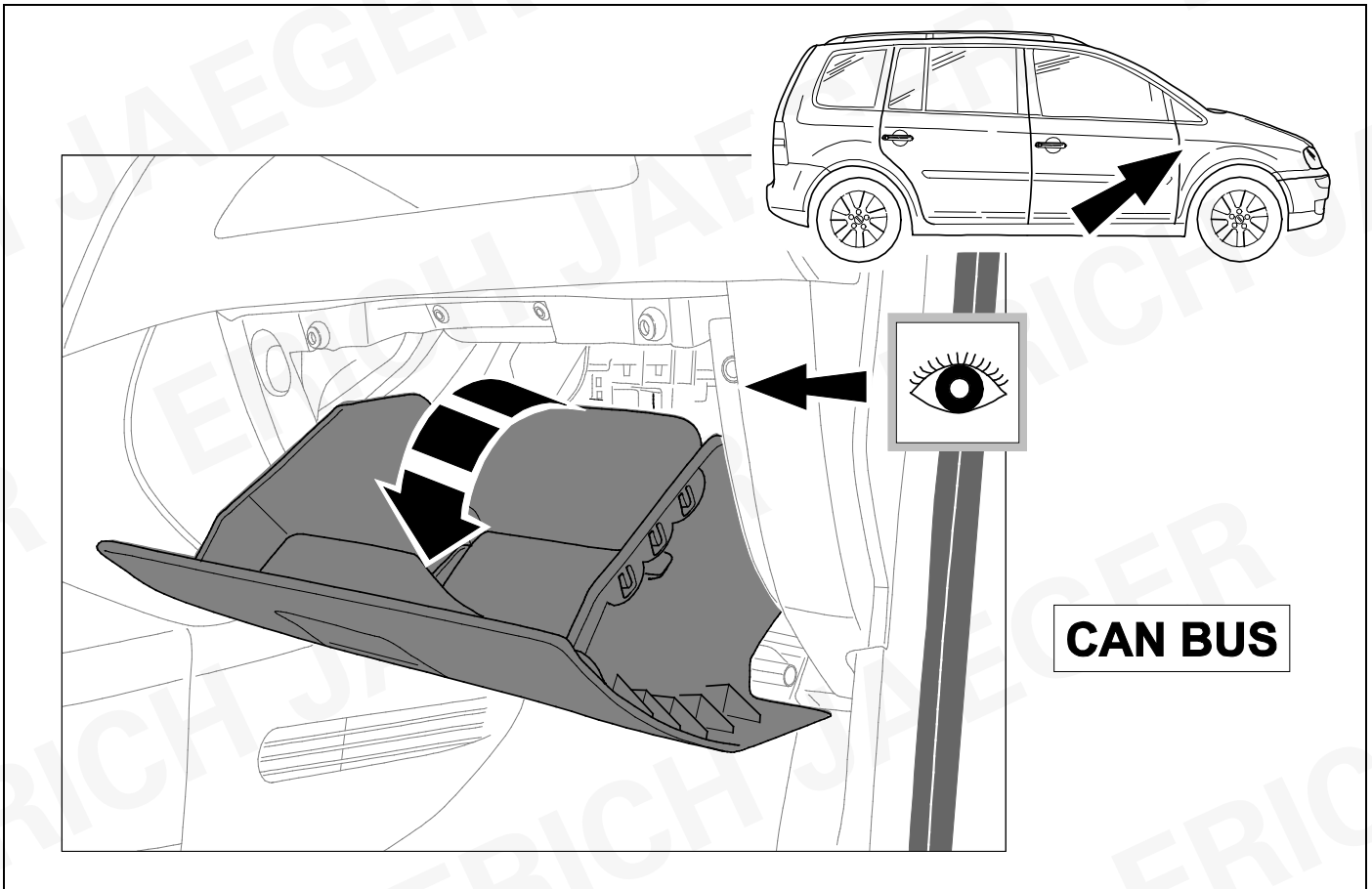

18

OPTION 1

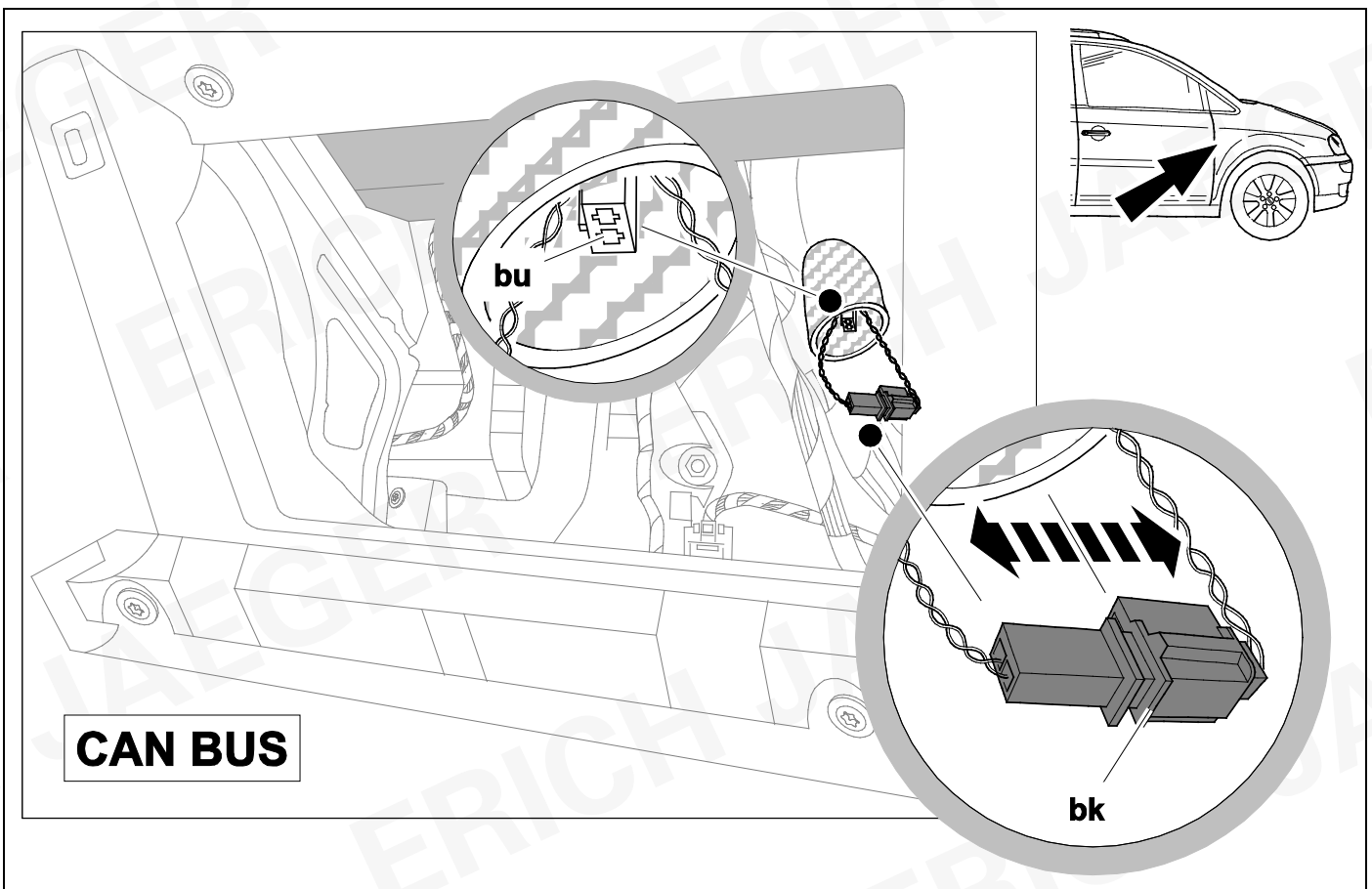

19

OPTION 1

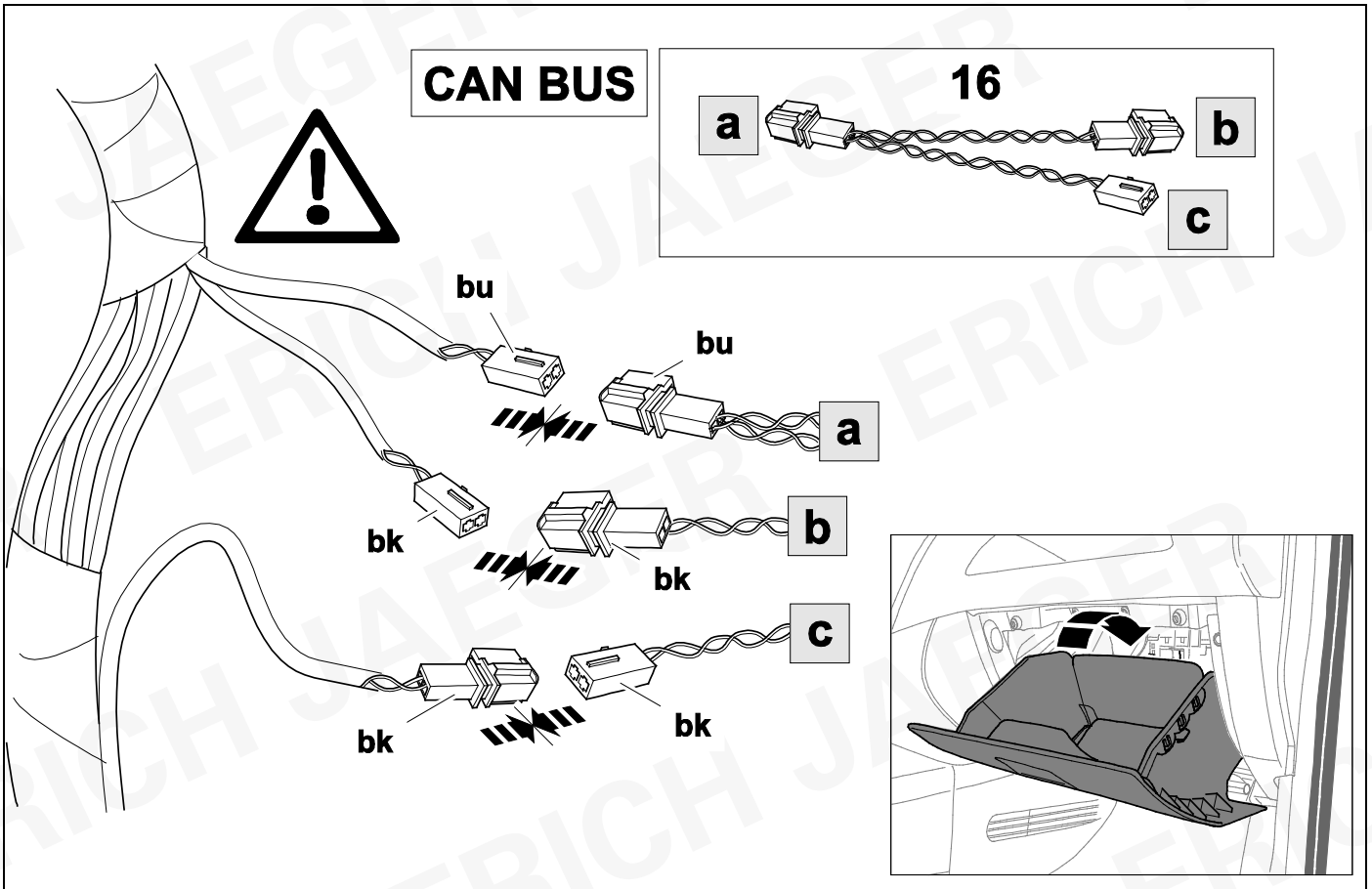

20

Vehicles without trailer preparation

OPTION 2

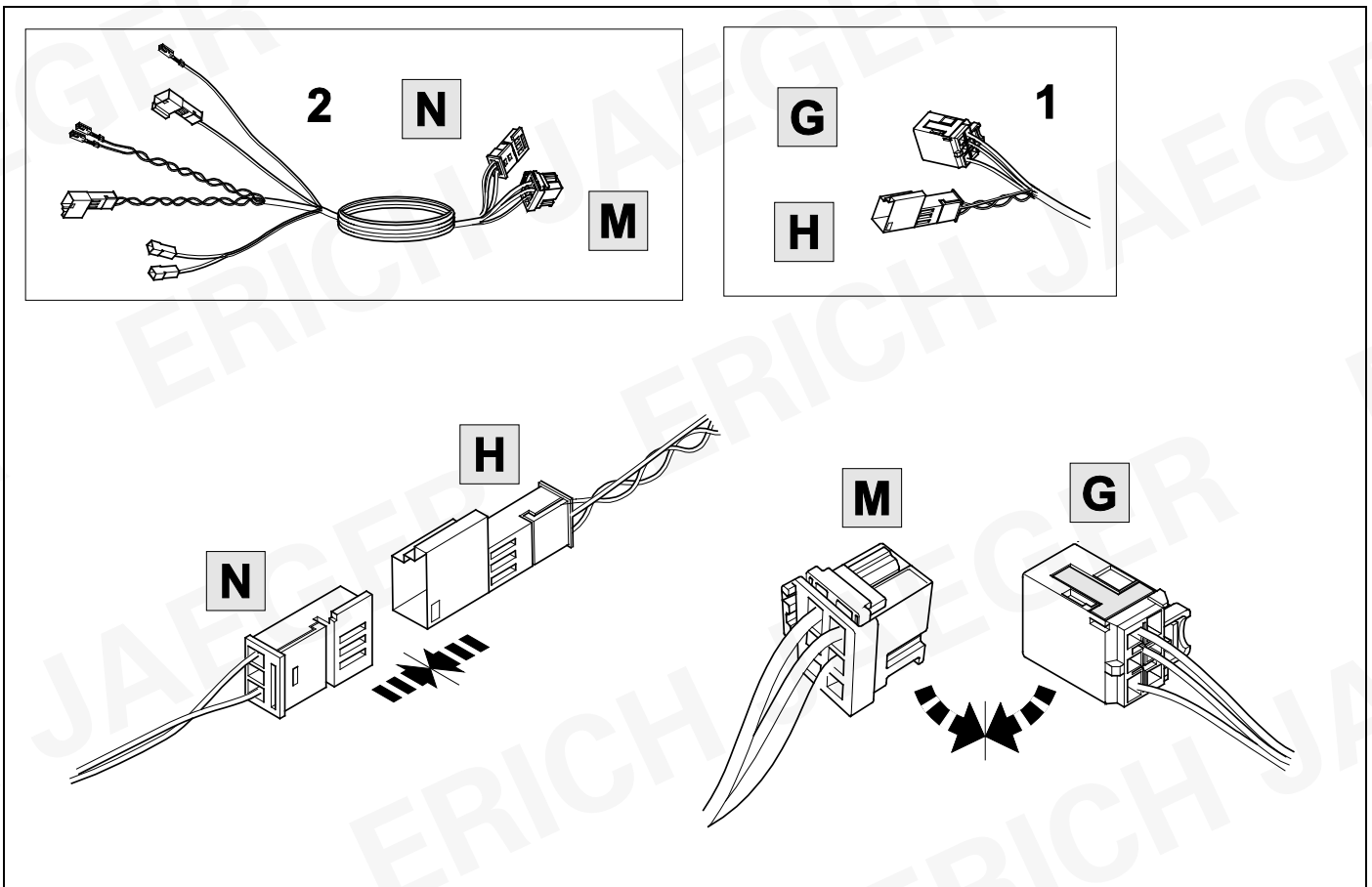



21

OPTION 2

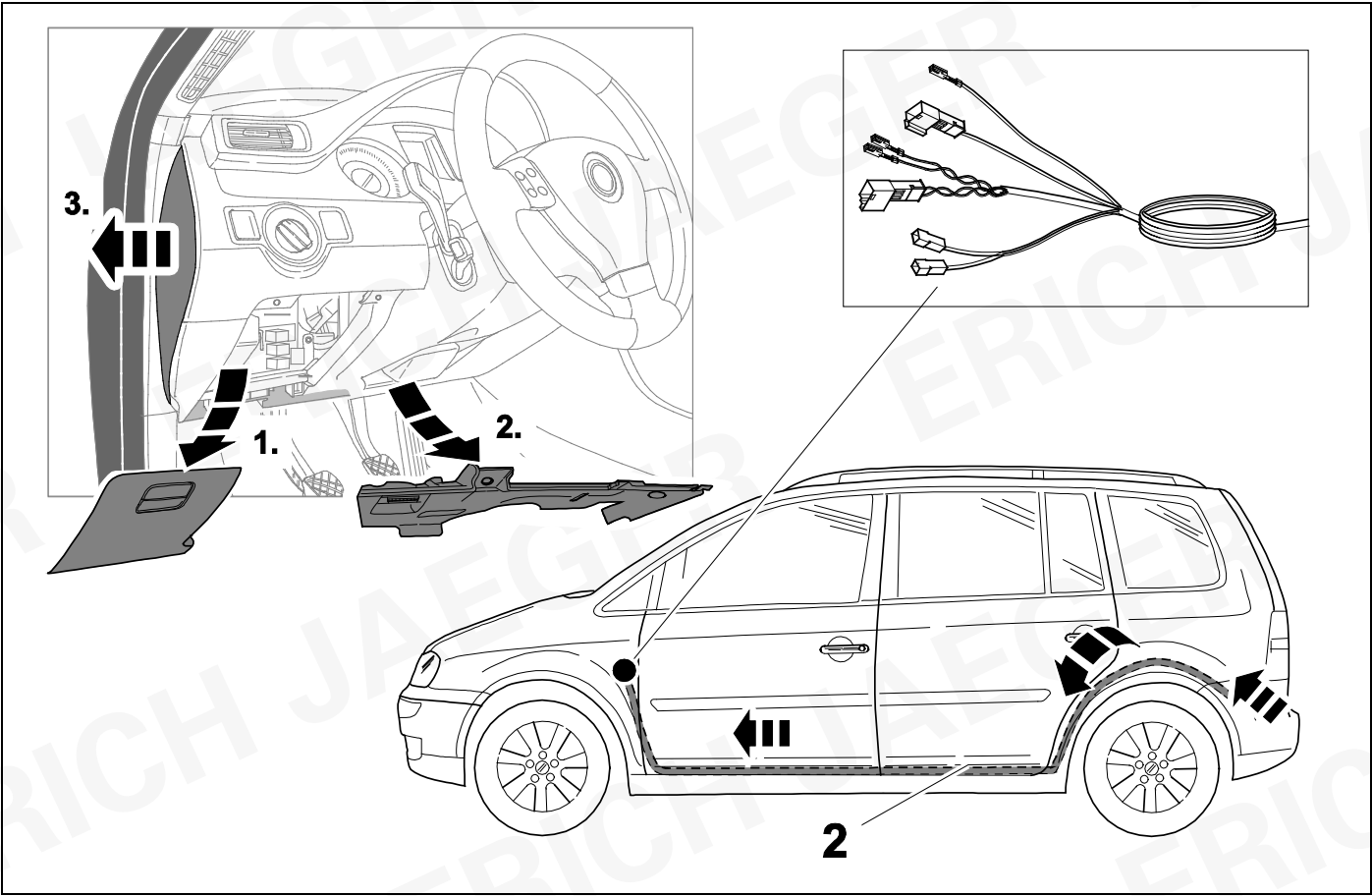

22



9

OPTION 2

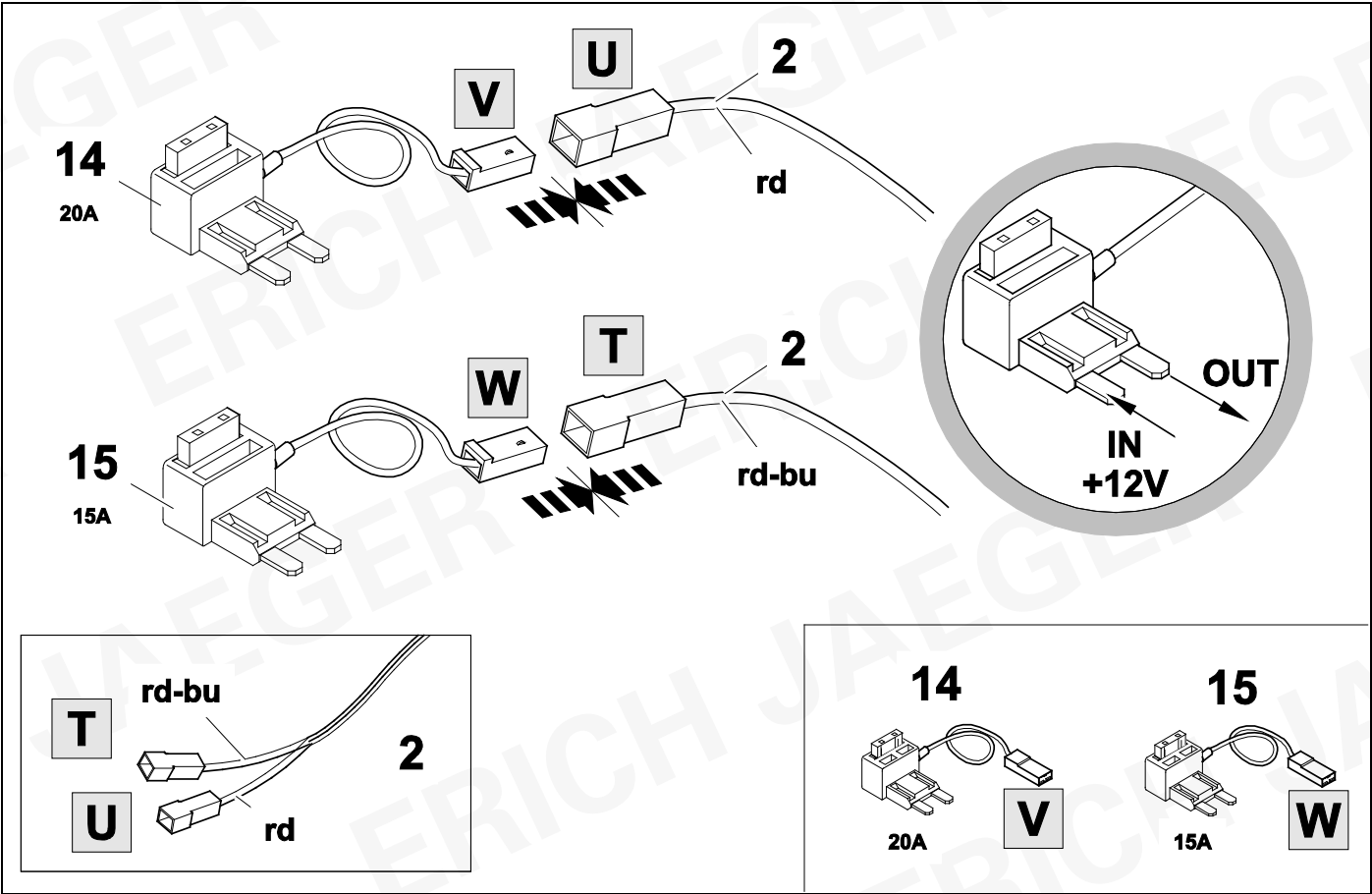

23



42

OPTION 2

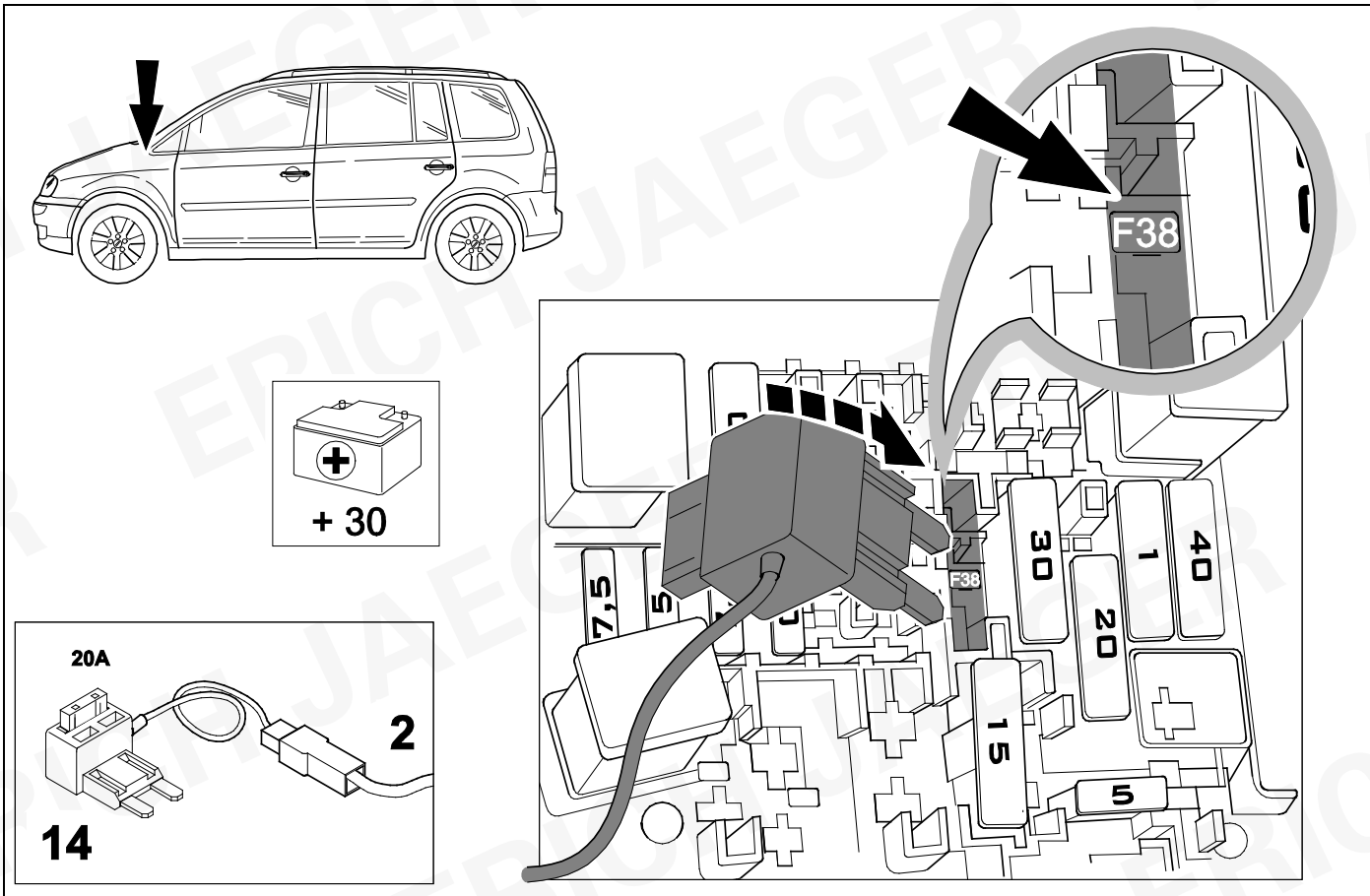

24



42

OPTION 2

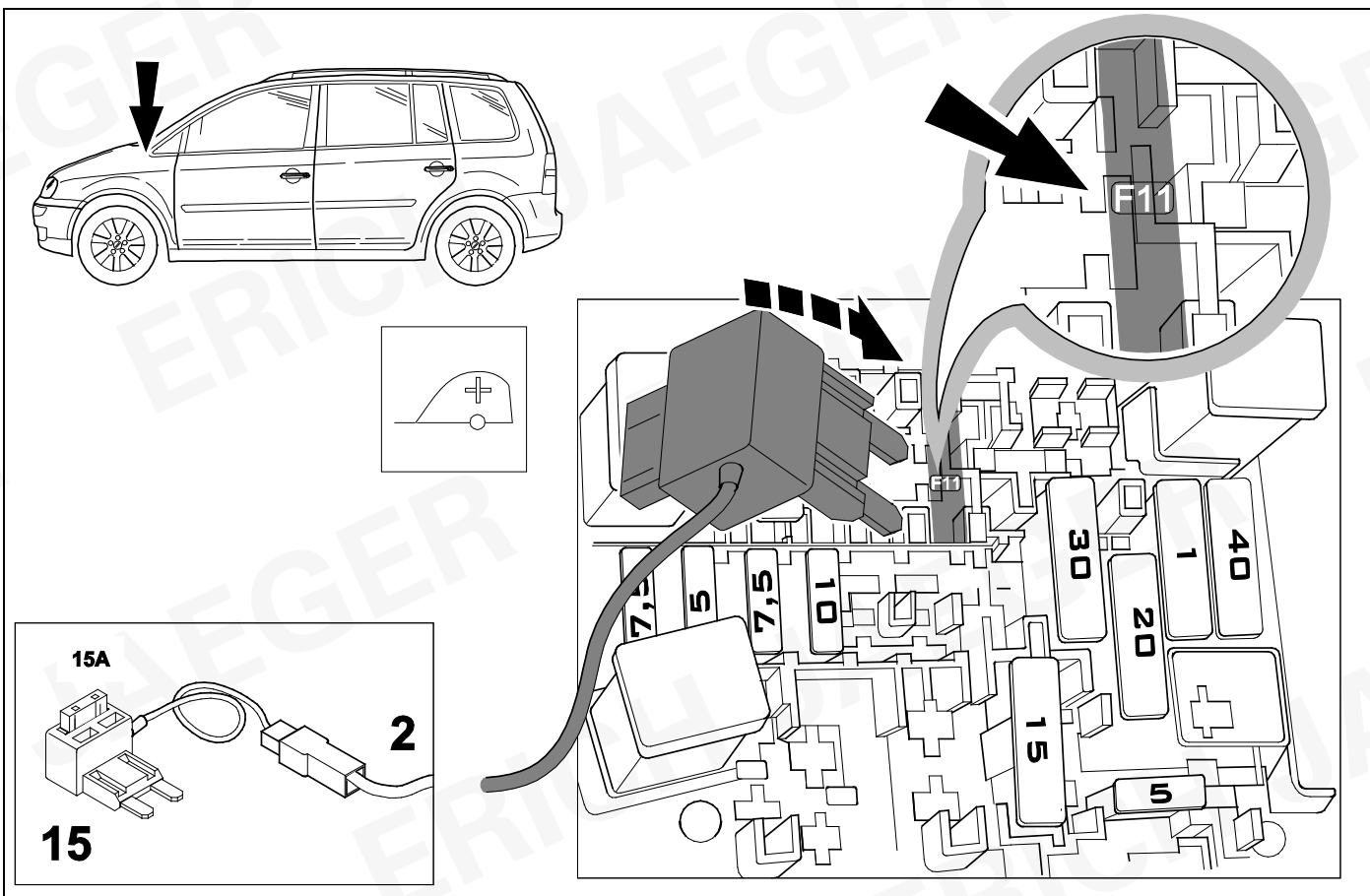

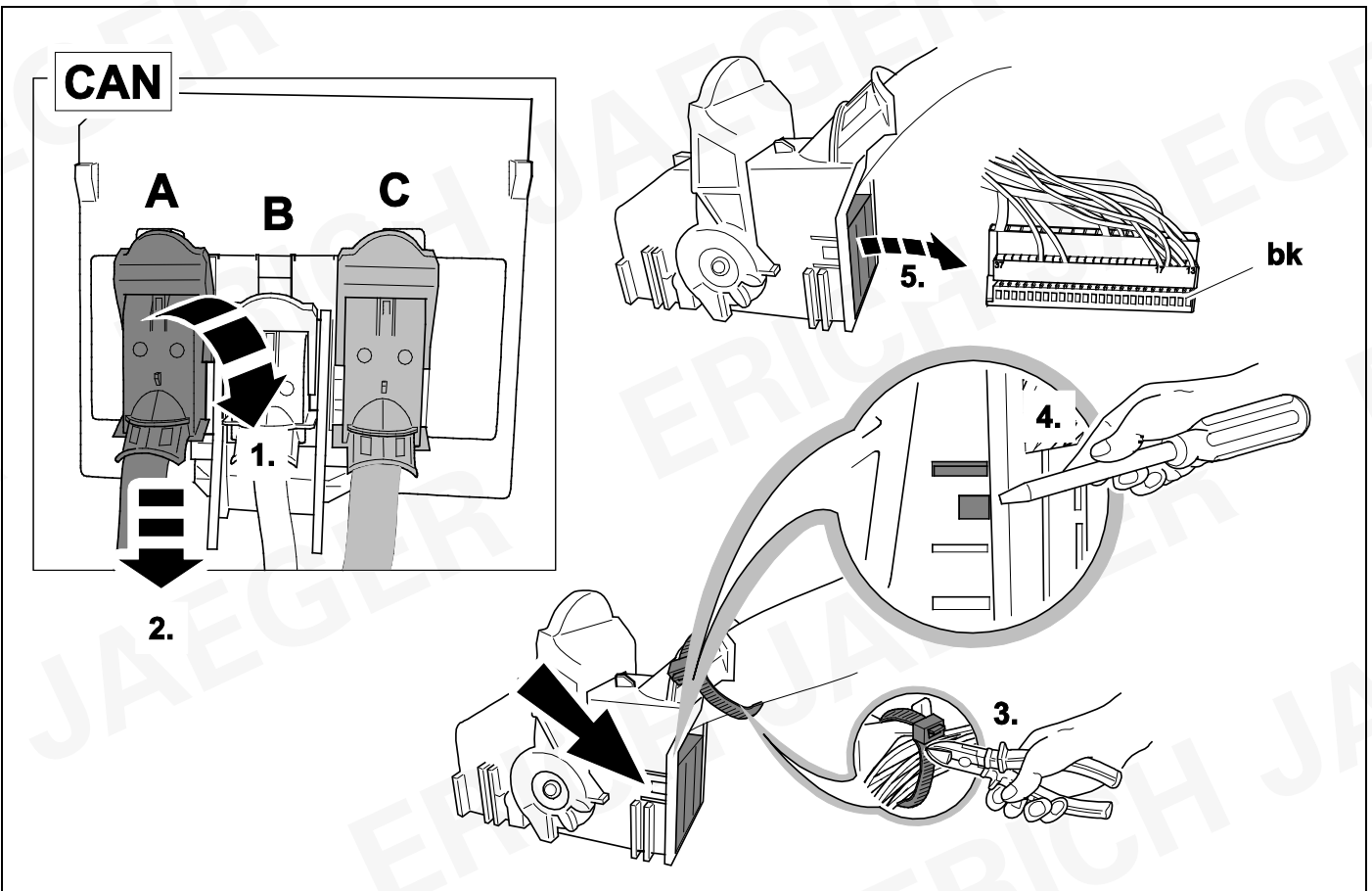
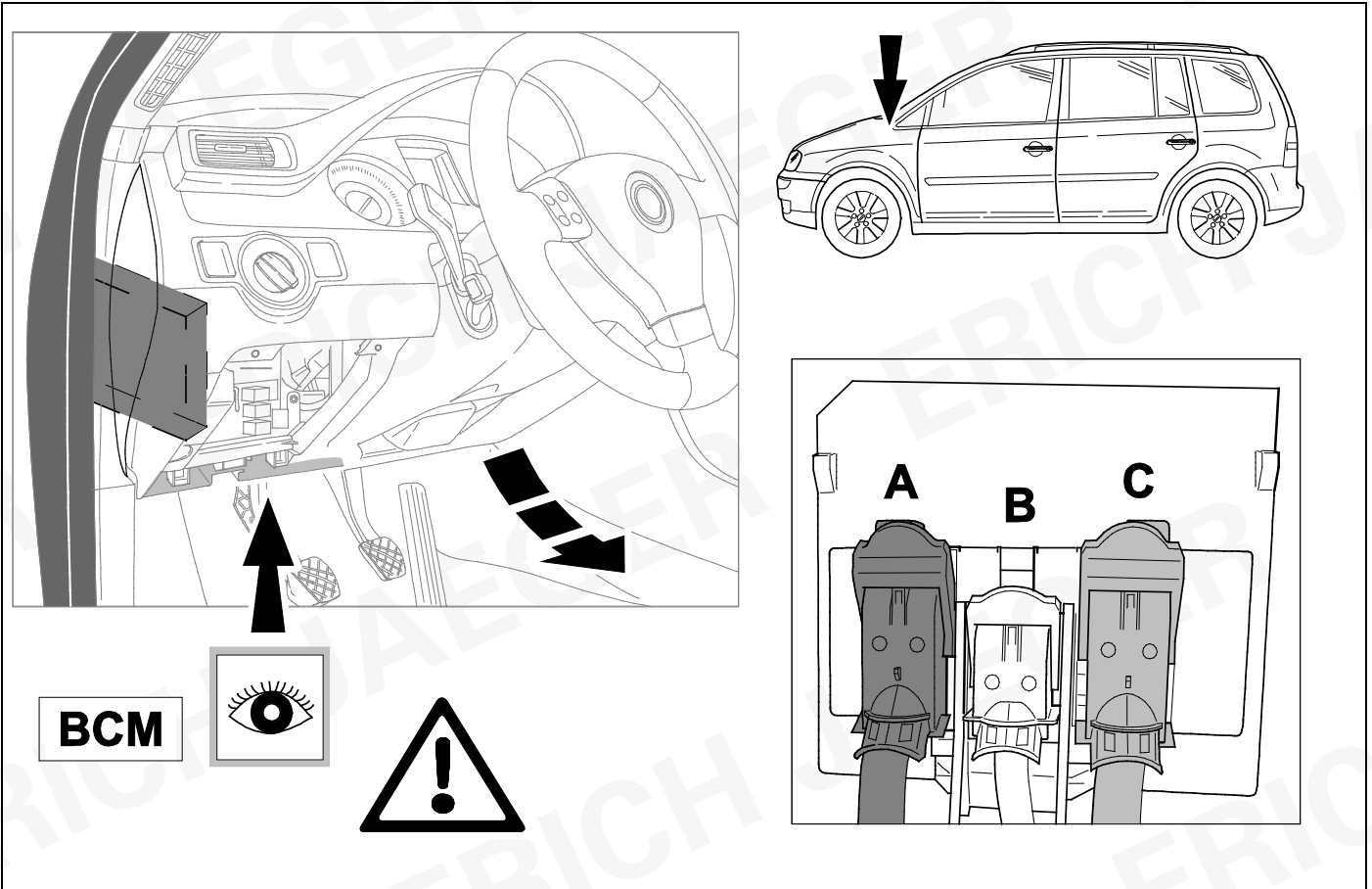

27



9

OPTION 2

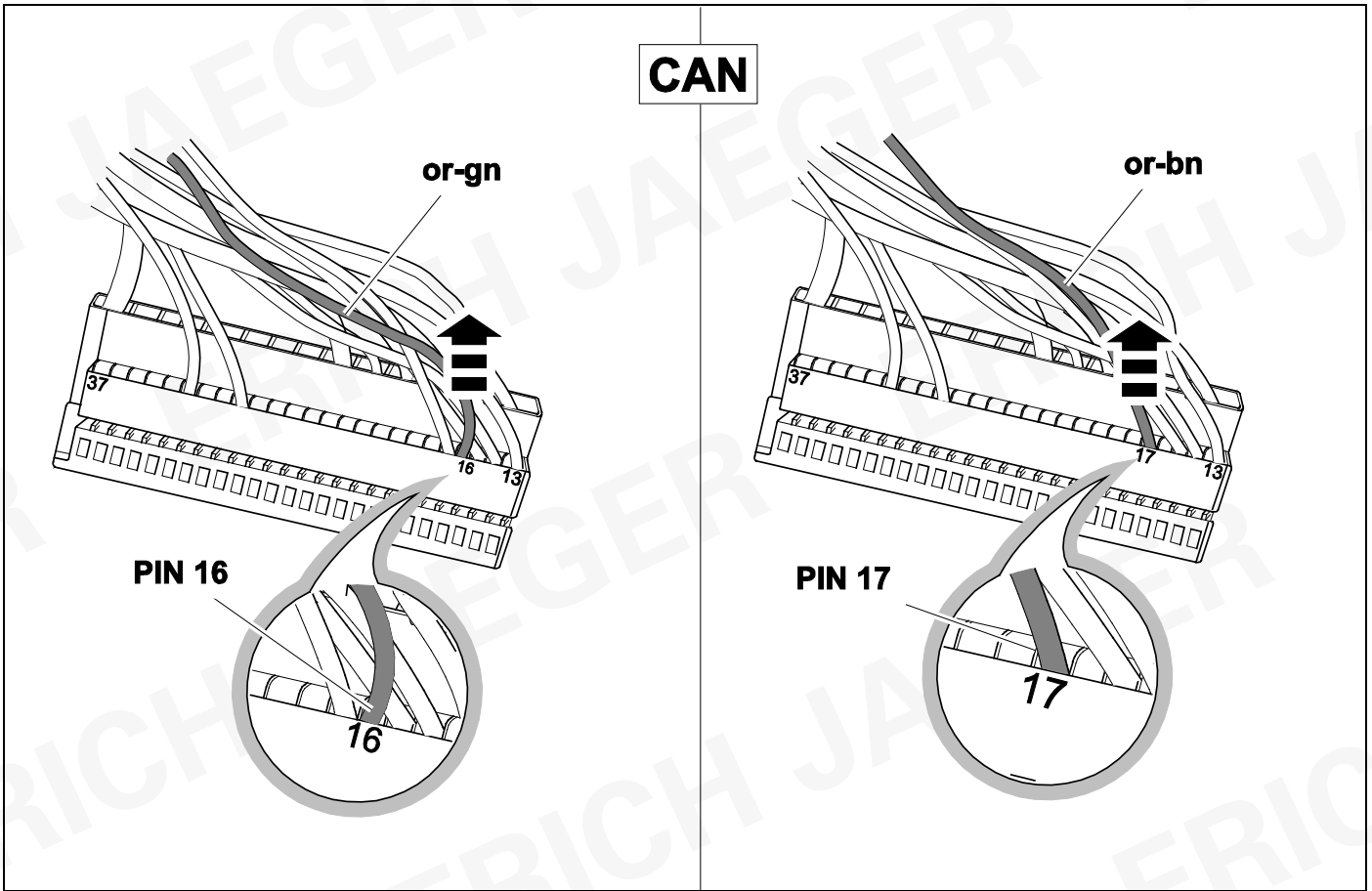

28



9

OPTION 2

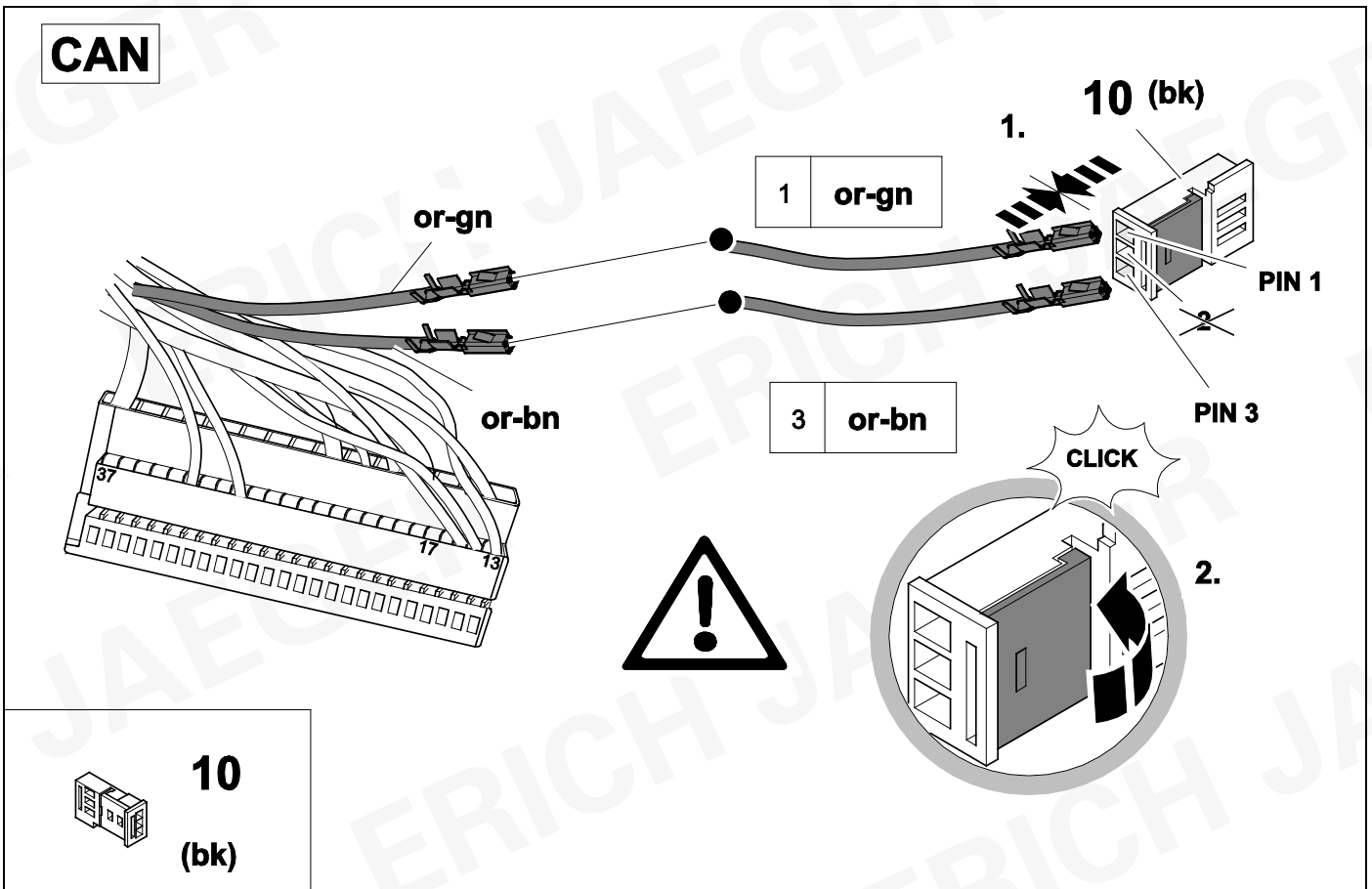



CAN

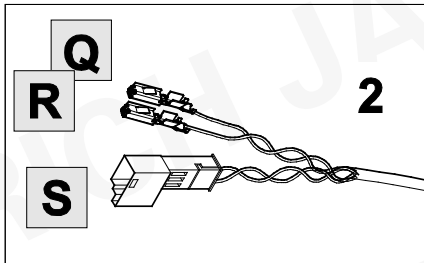
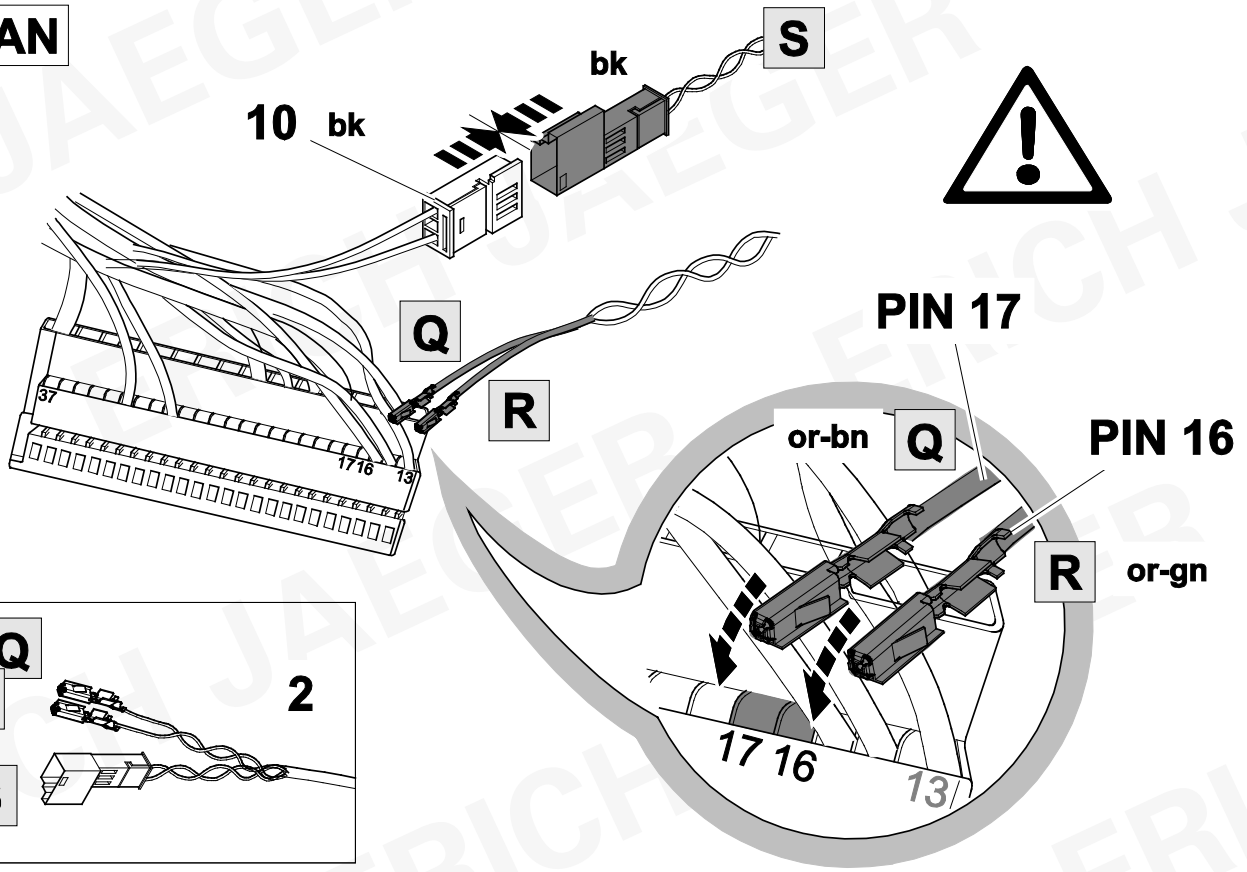

CAN

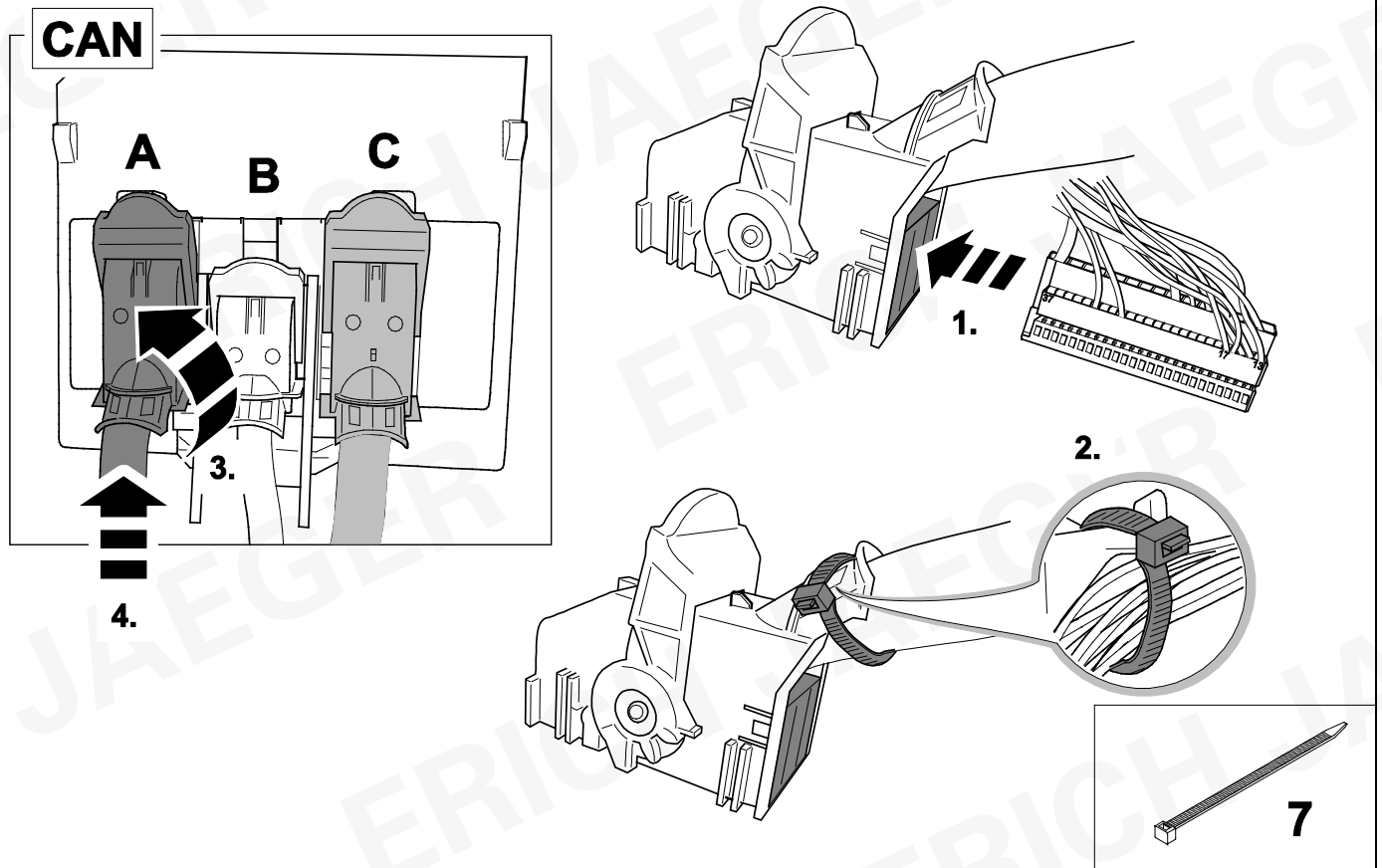

31



9

OPTION 2

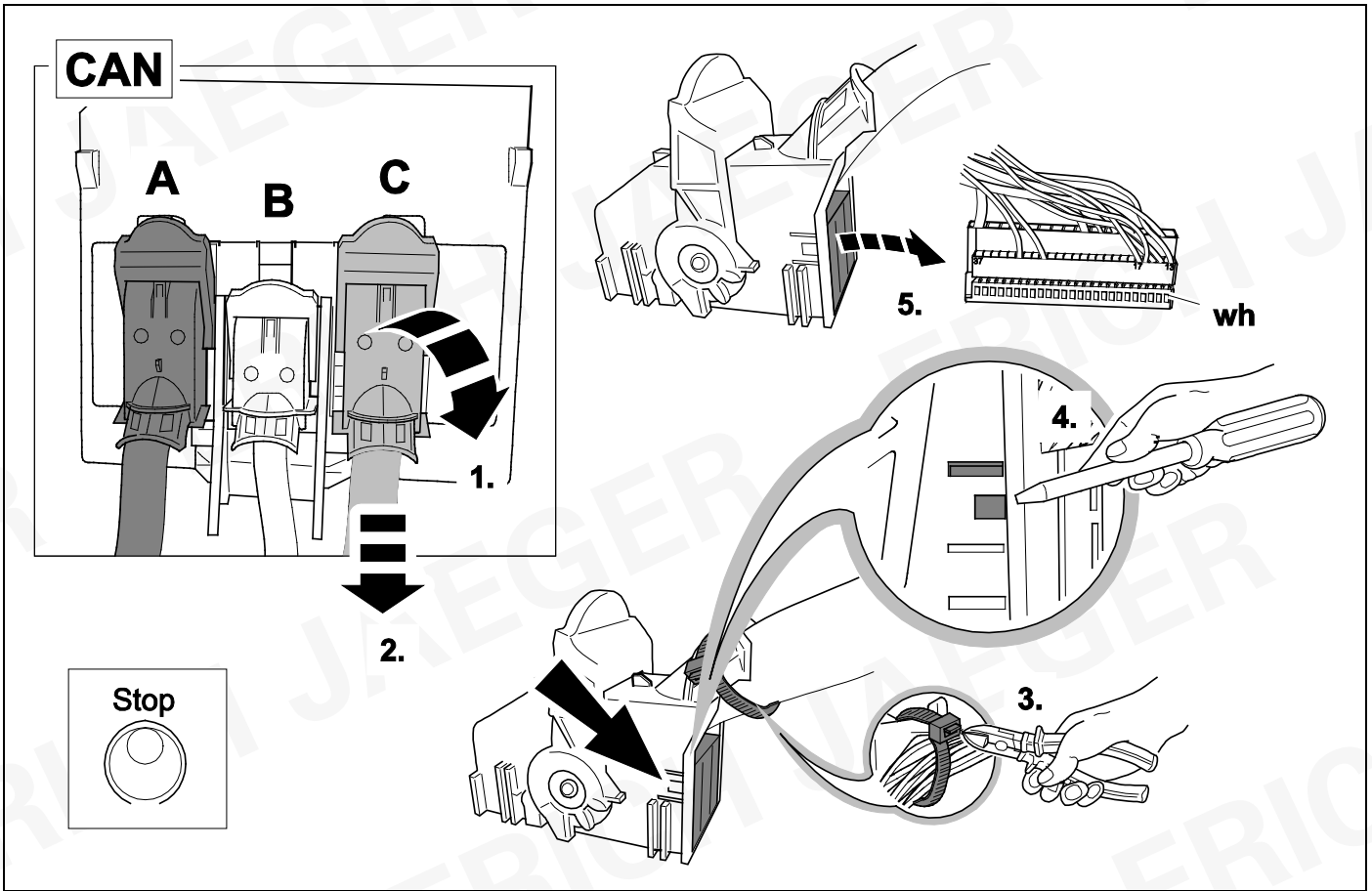

32



9

OPTION 2

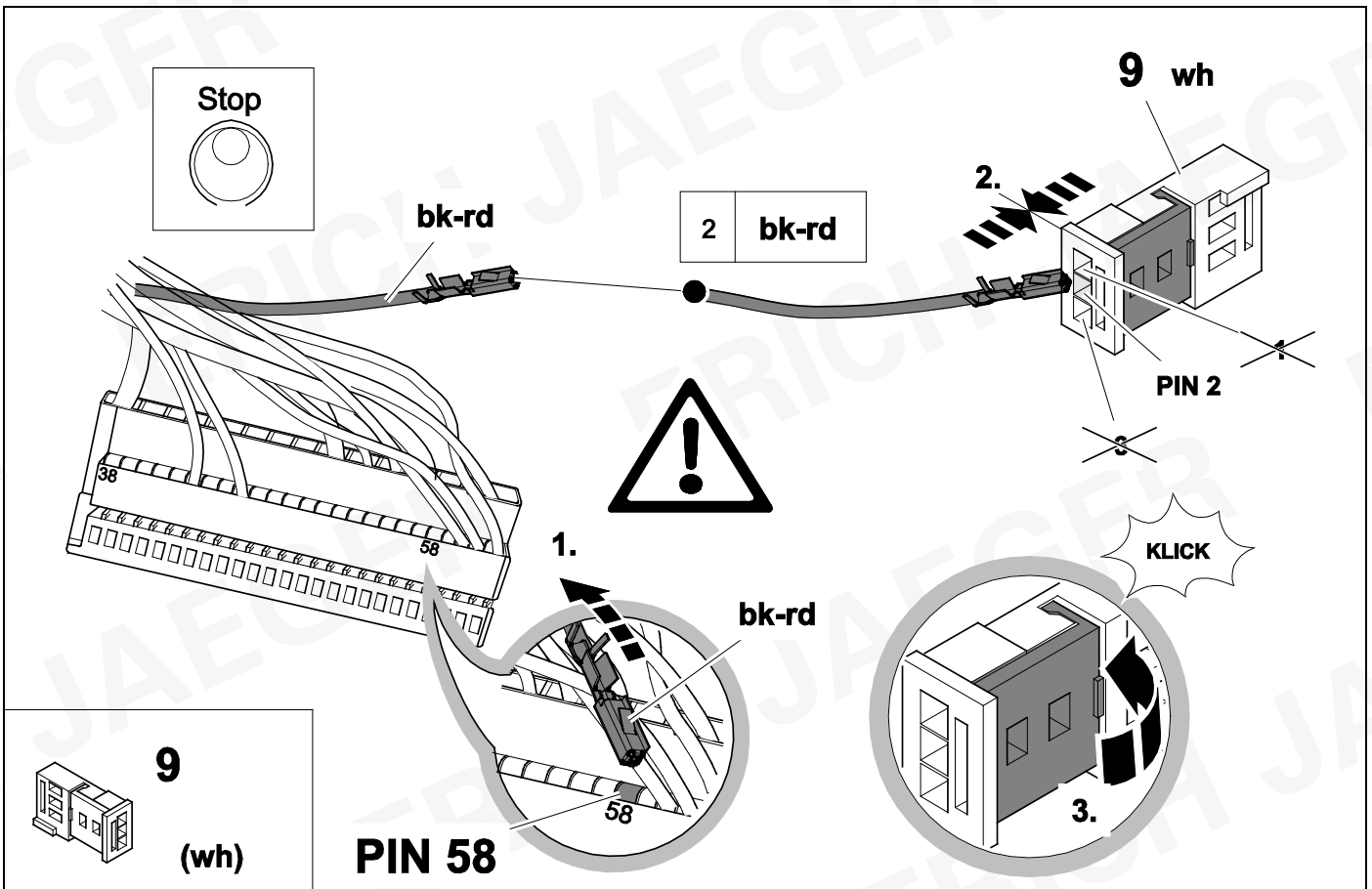

33



9

OPTION 2

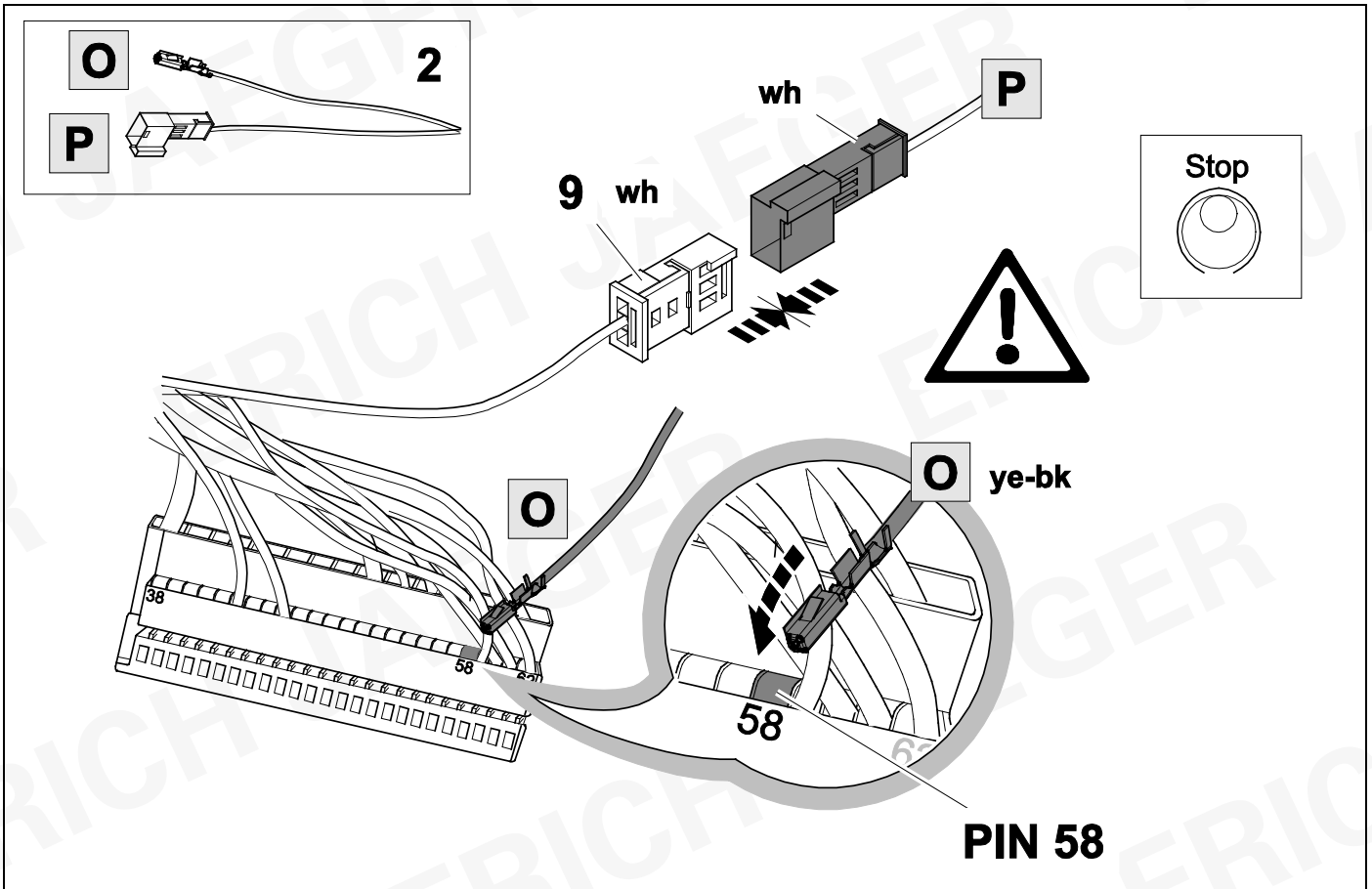

34

OPTION 2

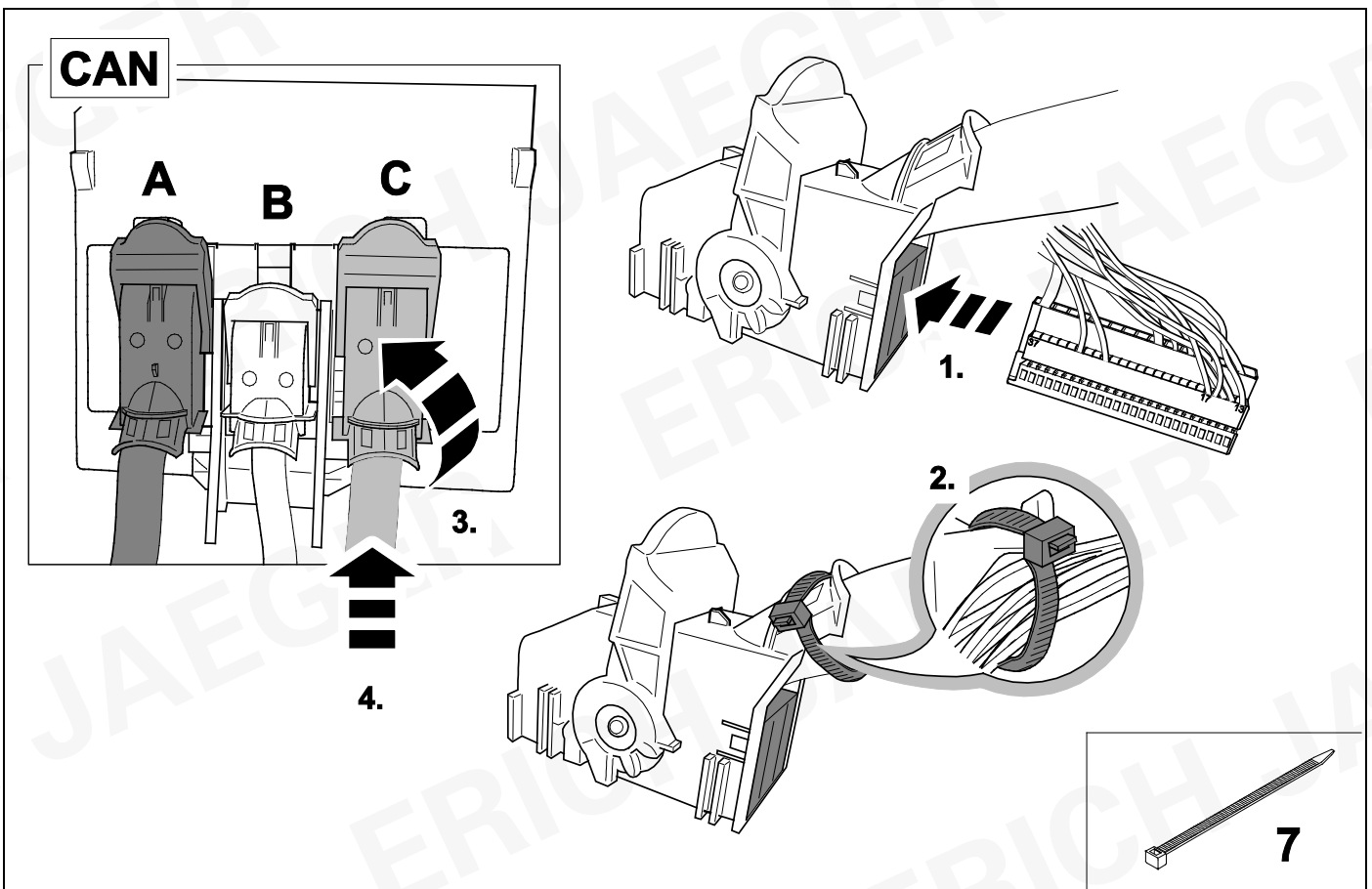

35

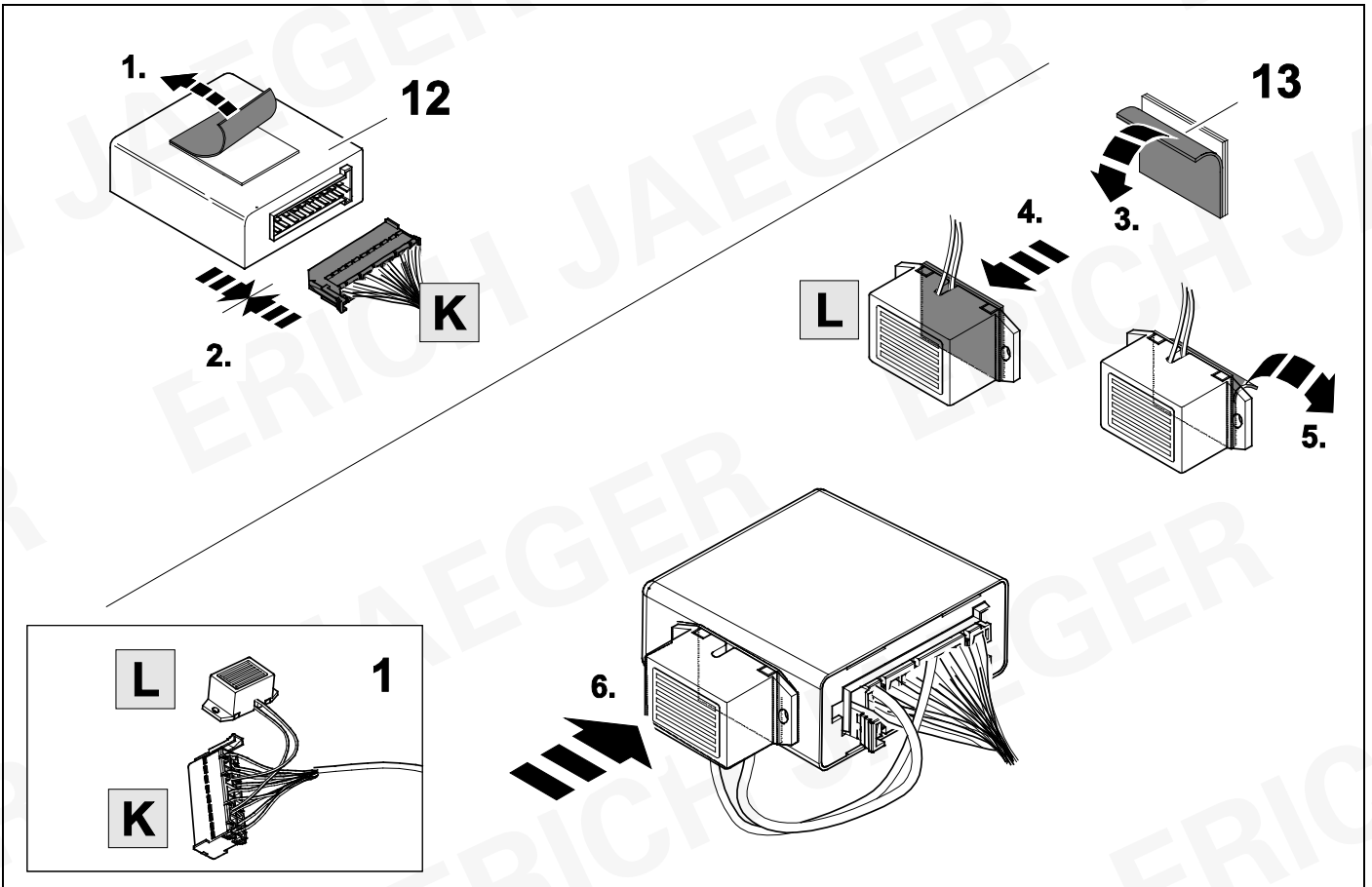

36

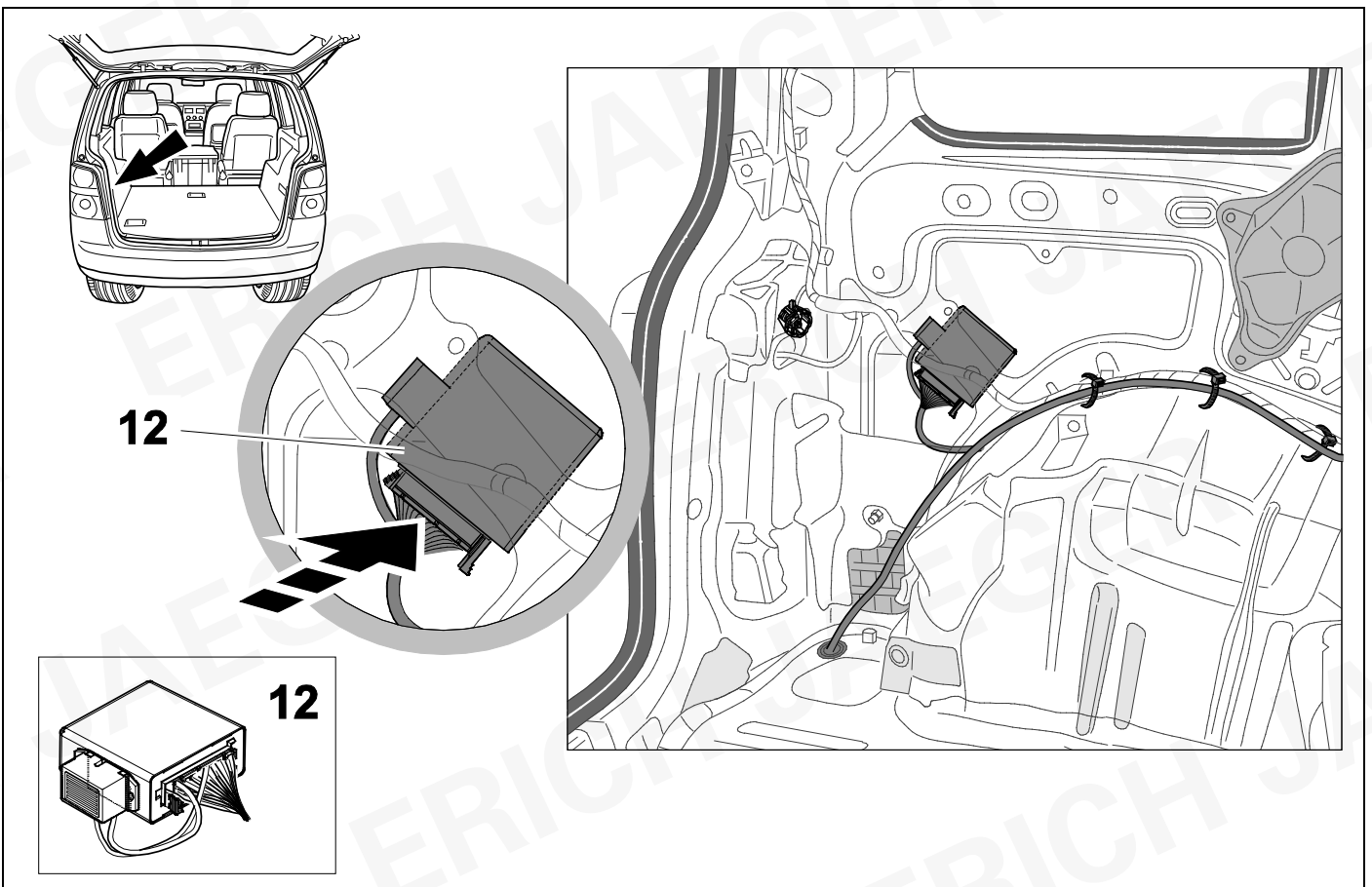



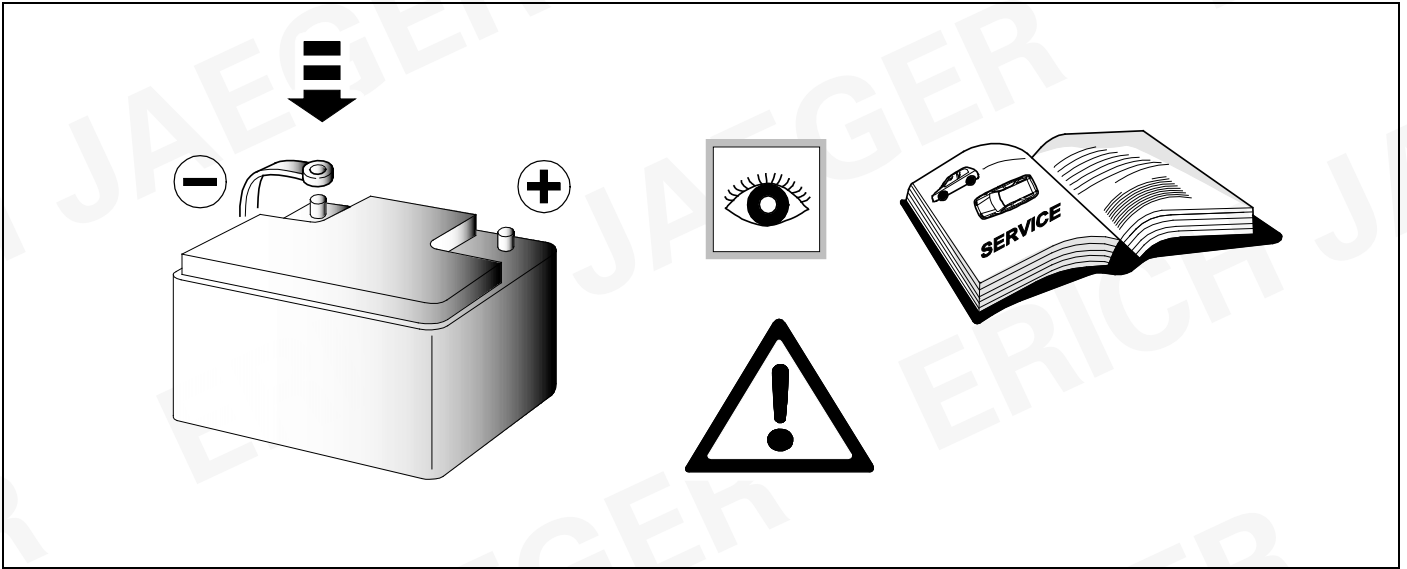

37

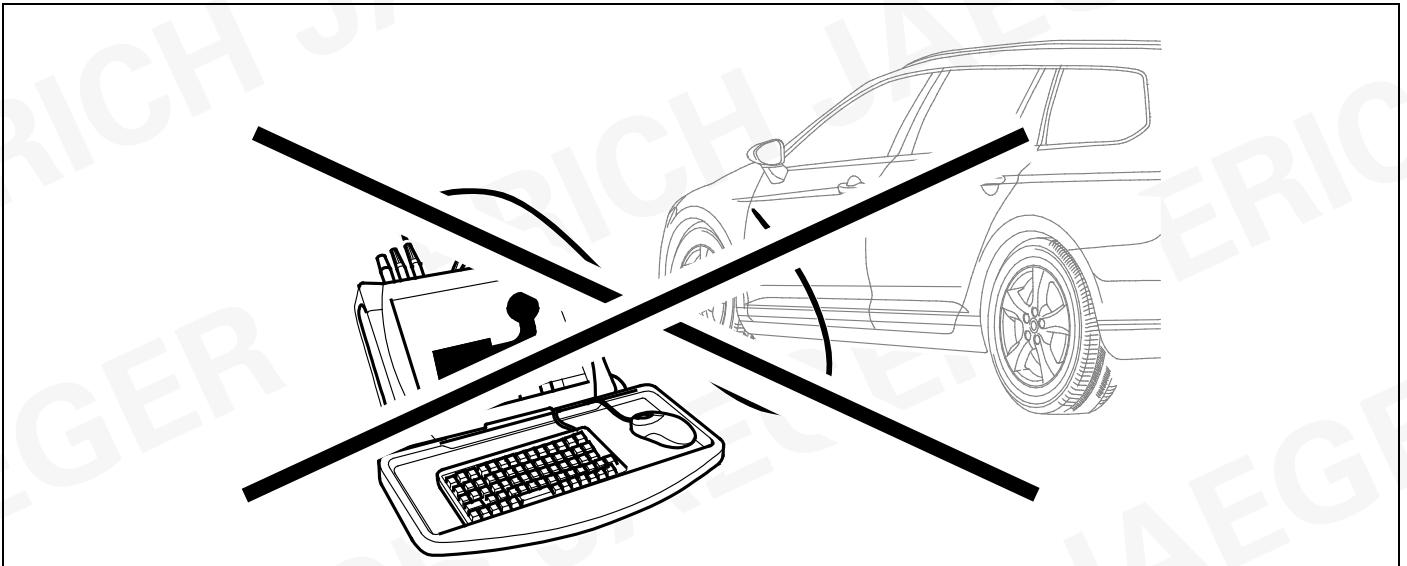

38

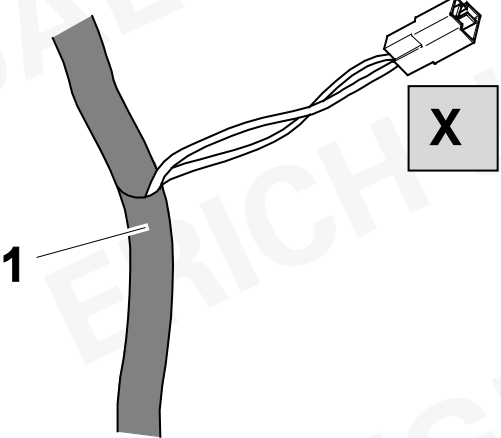
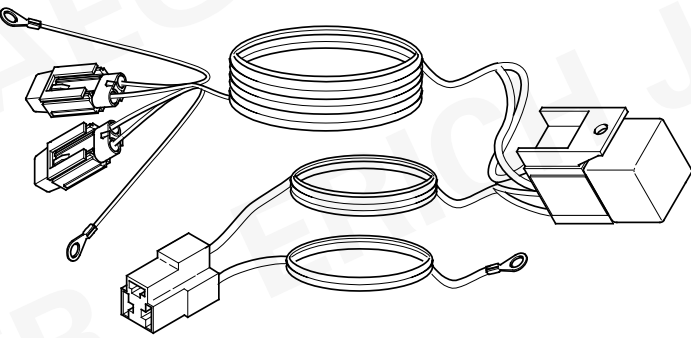

# 39 OPTIONAL

		ERICH JAEGER Artikelnummer: ERICH JAEGER part number:	<b>721074</b>
			

## 40 CHECK

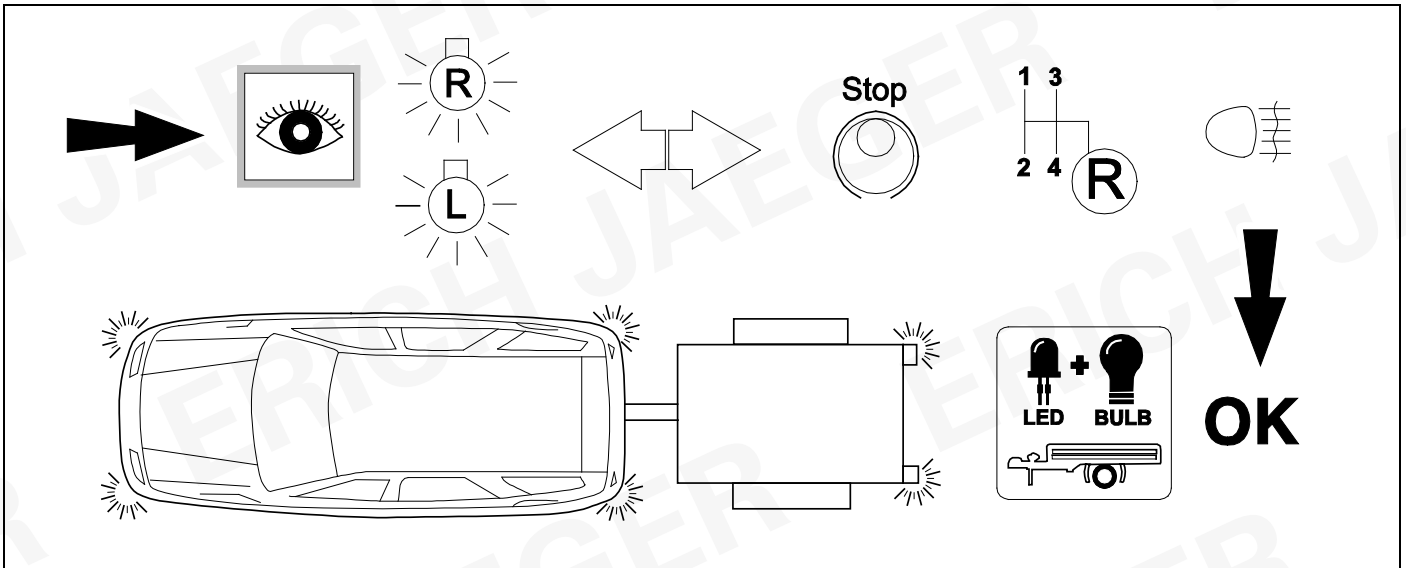

## 41 CHECK

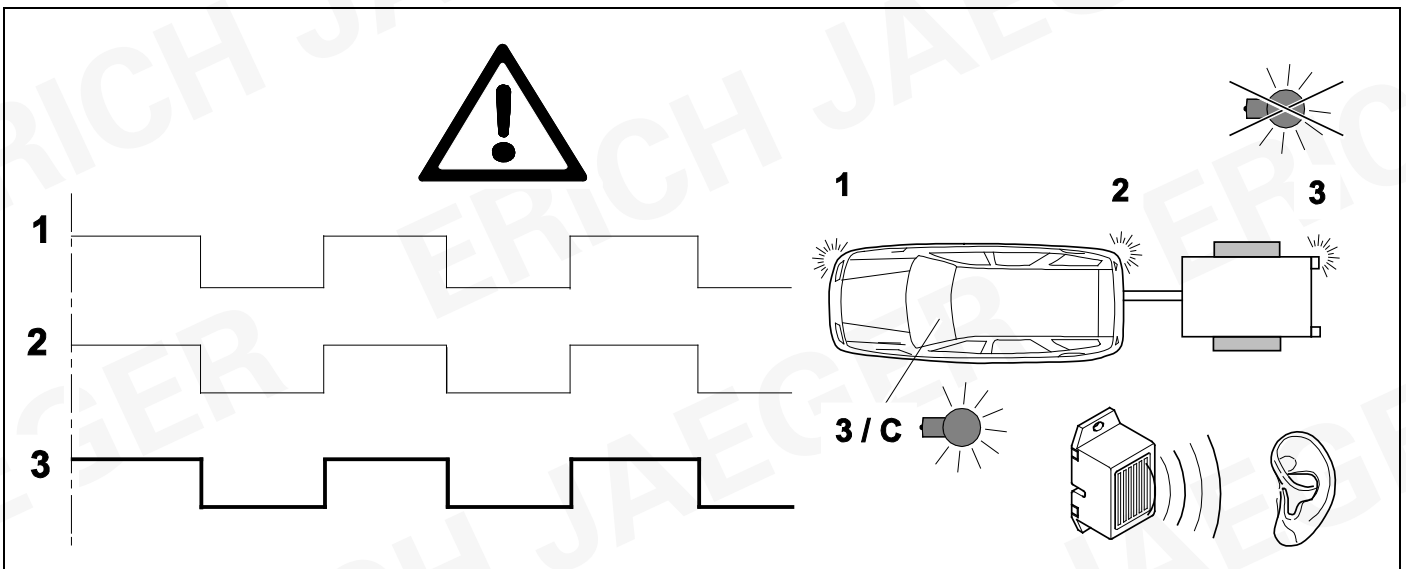

## 42 INFORMATION



23 + 24

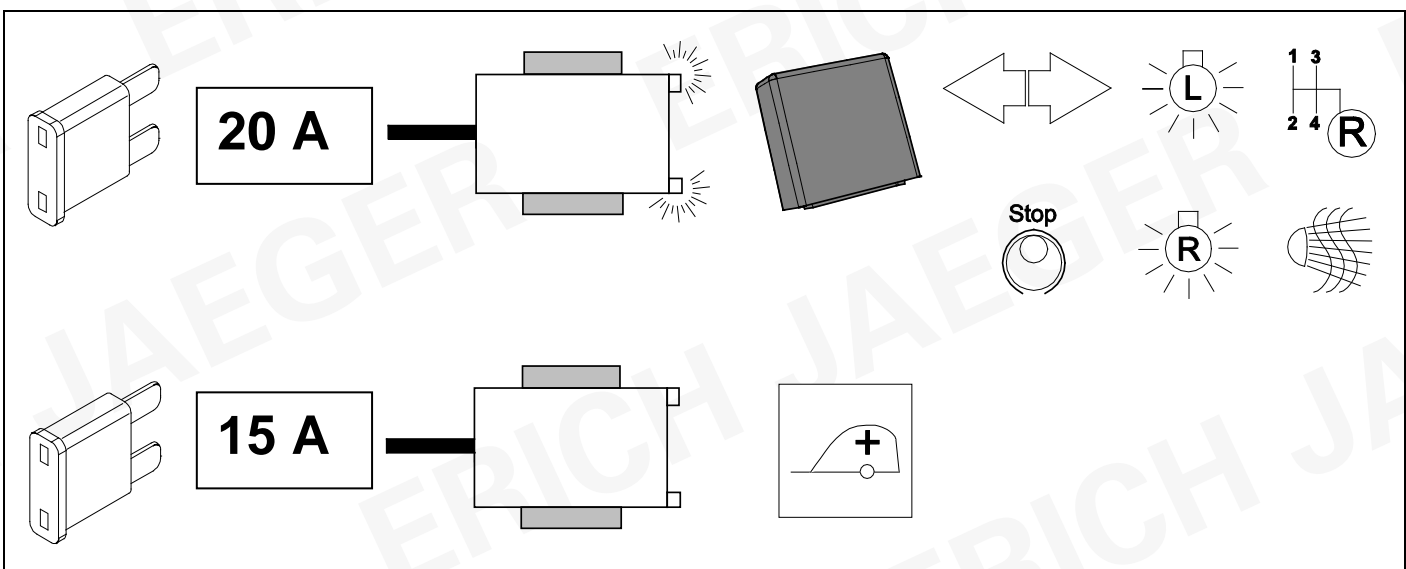

## OPTION vehicle coding

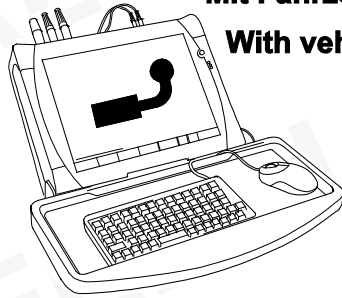

Mit Fahrzeugkodierung  
With vehicle coding

44



47



**! Achtung !**

Diese Kodierung kann eventuell nach einem Besuch bei einer autorisierten Werkstatt verloren gehen!

**! Attention !**

These codings may be lost after visiting an authorized workshop!

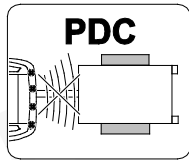

PDC

**TSP**  
Trailer  
Stability  
Program

**P**  
Trailer  
Assistent



## OPTION vehicle coding

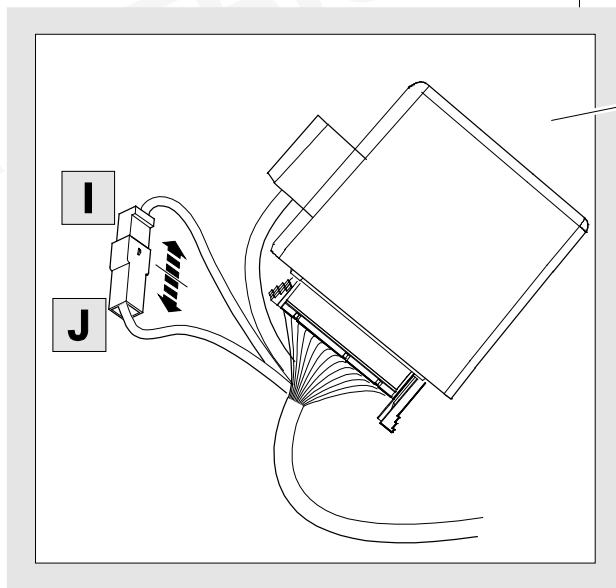
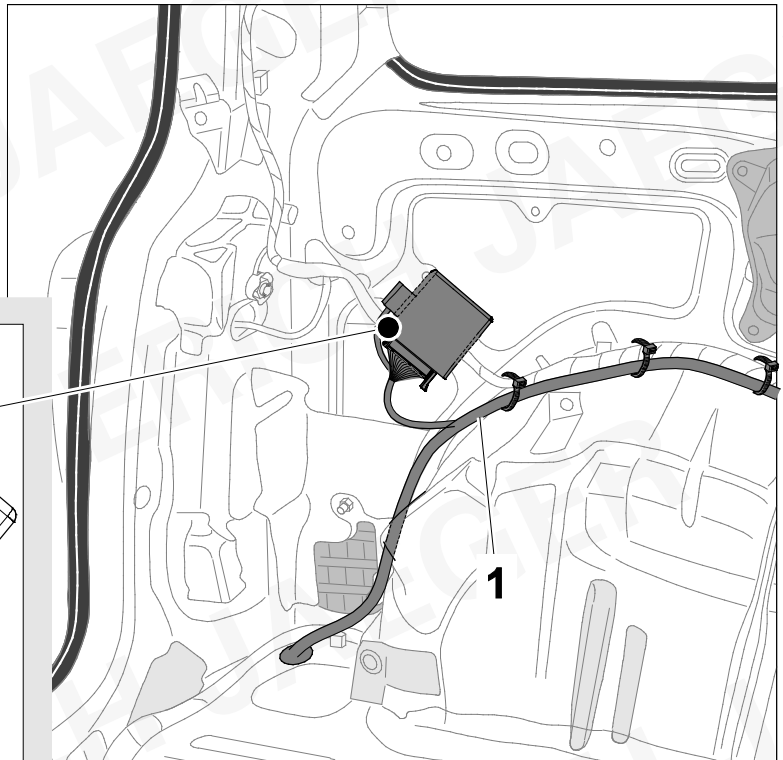
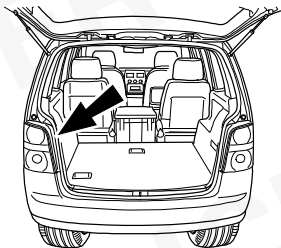

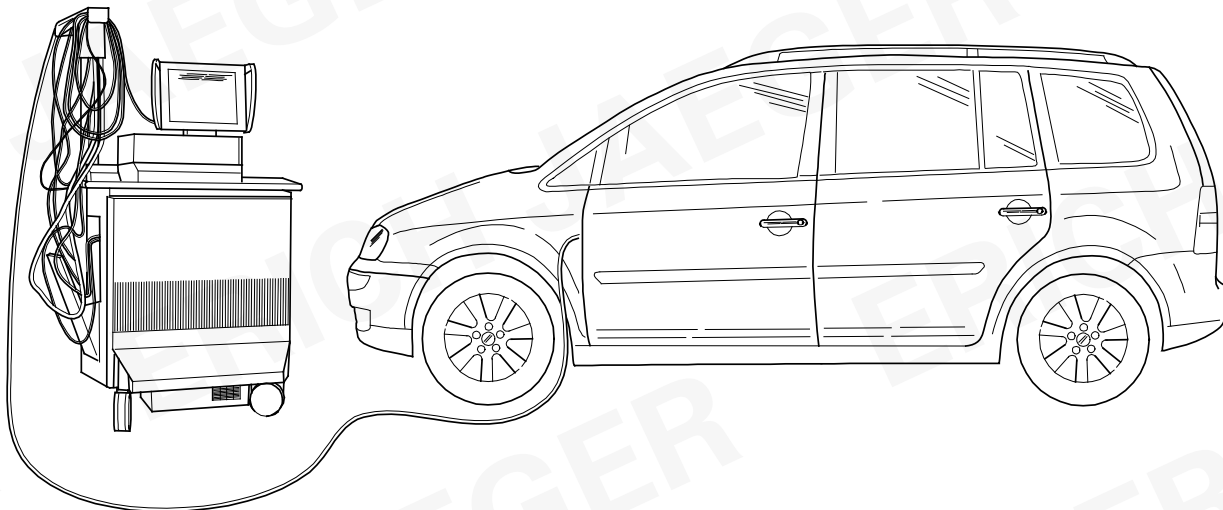
**D****Codierung bitte wie folgt durchführen:**

- Alternative Diagnosedienstleister bzw. Diagnosemethoden (lokal / offline) :
  - ODIS / VCDS
  - Hella Gutmann ( Seite 26 )
  - Autologic
  - Bosch / KTS
  - SP Diagnostic
  - SUN
  - Westfalia Auto Code
  - etc. pp.

**GB****Please effect coding as follows:**

- Alternative Diagnosis Services or diagnostic methods (local / offline) :
  - ODIS / VCDS
  - Hella Gutmann ( page 26 )
  - Autologic
  - Bosch / KTS
  - SP Diagnostic
  - SUN
  - Westfalia Auto Code
  - etc. pp.

**F****Veillez suivre le codage suivant:**

- Diagnostic services alternatives ou les méthodes de diagnostic (local/hors ligne) :
  - ODIS / VCDS
  - Hella Gutmann ( page 26 )
  - Autologic
  - Bosch / KTS
  - SP Diagnostic
  - SUN
  - Westfalia Auto Code
  - etc. pp.

**I****Favore codifica effettuate come segue:**

- -Alternativa Diagnosi Servizio o metodi diagnostici (locale/offline) :
  - ODIS / VCDS
  - Hella Gutmann ( pagina 26 )
  - Autologic
  - Bosch / KTS
  - SP Diagnostic
  - SUN
  - Westfalia Auto Code
  - etc. pp.

**E****Por favor de codificación lleva a cabo como sigue:**

- Servicio de Diagnóstico alternativa o métodos de diagnóstico (locales/fuera de linea) :
  - ODIS / VCDS
  - Hella Gutmann ( pagina 26 )
  - Autologic
  - Bosch / KTS
  - SP Diagnostic
  - SUN
  - Westfalia Auto Code
  - etc. pp.

**NL****Gelieve codering ais volgt ultgevoerd:**

- Alternatief Diagnose Dienst of diagnostische methoden (lokale/offline) :
  - ODIS / VCDS
  - Hella Gutmann ( page 26 )
  - Autologic
  - Bosch / KTS
  - SP Diagnostic
  - SUN
  - Westfalia Auto Code
  - etc. pp.

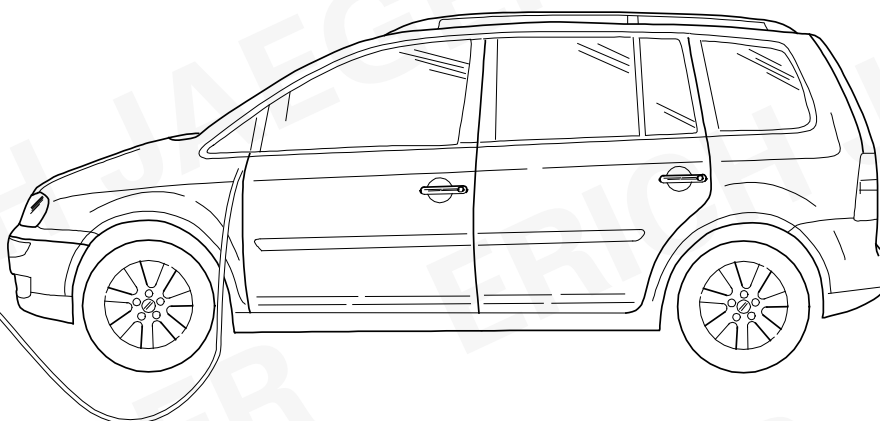
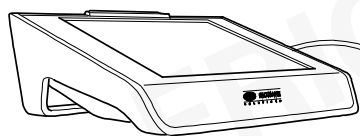

(D)	(GB)	(F)
<p><b>Die Aktivierung der Anhängerfunktionen muss wie folgt durchgeführt werden:</b></p> <ol style="list-style-type: none"> <li>1. Fahrzeugauswahl</li> <li>2. Zu Diagnose – Codierung wechseln</li> <li>3. Anhängerkupplung de-/aktivieren</li> <li>4. Diagnose Interface Bus auswählen</li> <li>5. Anleitung folgen</li> </ol> <p><b>Fahrzeuge mit Assistenzsystemen</b></p> <ol style="list-style-type: none"> <li>6. AHK an Assistenzsysteme anpassen ausführen</li> <li>7. Anleitung folgen</li> <li>8. Diagnose</li> <li>9. Fehlerspeicher auslesen, ggf. löschen</li> <li>10. Fertig</li> </ol>	<p><b>The activation of the trailer functions must be performed:</b></p> <ol style="list-style-type: none"> <li>1. Vehicle selection</li> <li>2. switch to diagnostics - coding</li> <li>3. Deactive/aktive trailer coupling</li> <li>4. Select diagnostic interface Bus</li> <li>5. Follow instructions</li> </ol> <p><b>Vehicle with assistance systems</b></p> <ol style="list-style-type: none"> <li>6. perform adaptation of trailer coupling on assistance systems</li> <li>7. Follow instructions</li> <li>8. Diagnostics</li> <li>9. Read out error memory, delete if necessary</li> <li>10. Done</li> </ol>	<p><b>Pour activer l'attelage, procéder de la façon suivante:</b></p> <ol style="list-style-type: none"> <li>1. Choix véhicule</li> <li>2. Aller dans le diagnostic - codage</li> <li>3. Activer/désactiver le diagnostic</li> <li>4. Sélectionner le BUS d'interface de diagnostic</li> <li>5. Suivre les instructions</li> </ol> <p><b>Véhicules avec systèmes d'aide</b></p> <ol style="list-style-type: none"> <li>6. Effectuer une adaptation d'attelage aux systèmes d'aide</li> <li>7. Suivre les instructions</li> <li>8. Diagnostic</li> <li>9. Lire la mémoire de défaut et effacer les codes d'erreur éventuellement mémorisés</li> <li>10. Terminé</li> </ol>
(I)	(E)	(NL)
<p><b>Per attivare le funzioni del rimorchio, procedere nel modo seguente:</b></p> <ol style="list-style-type: none"> <li>1. Scelta vettura</li> <li>2. Passare alla Diagnosi - Codifica</li> <li>3. Attivare / disattivare il gancio di traino</li> <li>4. Selezionare il interfaccia di diagnosi</li> <li>5. Seguire le istruzioni</li> </ol> <p><b>Veicoli noc suster di assistenza</b></p> <ol style="list-style-type: none"> <li>6. adattare i suster installati</li> <li>7. Seguire le istruzioni</li> <li>8. Diagnosi</li> <li>9. Leggere la memoria guasti e cancellare, se necessario</li> <li>10. Fertig</li> </ol>	<p><b>La activación de las funciones de remolque debe la siguiente manera:</b></p> <ol style="list-style-type: none"> <li>1. Selección de vehículo</li> <li>2. Cambiar a diagnosis - Codificación</li> <li>3. Desactivar/ activar acoplamiento para remolque</li> <li>4. Selecciona diagnosis Interface Bus</li> <li>5. Seguir las instrucciones</li> </ol> <p><b>En vehículos noc sistemas de asistencia</b></p> <ol style="list-style-type: none"> <li>6. Ejecutar adaptación de acoplamiento para remolque a suster de asistencia</li> <li>7. Seguir las instrucciones</li> <li>8. Diagnosi</li> <li>9. Leer memoria de averias y borrarla si es necesario</li> <li>10. Listo</li> </ol>	<p><b>De activering van de aanhangerfuncties moet als volgt worden uitgevoerd:</b></p> <ol style="list-style-type: none"> <li>1. Voertuigselectie</li> <li>2. Ga naar Diagnose - Codering</li> <li>3. Aanhangwagenkoppeling deactiveren/activeren</li> <li>4. Diagnose interface bus selecteren</li> <li>5. Volg instructie op</li> </ol> <p><b>Bij voertuigen met assistentiesystemen</b></p> <ol style="list-style-type: none"> <li>6. „Aanhangwagenkoppeling aanpassen aan assistentiesystem“ uitvoeren</li> <li>7. Volg instructie op</li> <li>8. Diagnose</li> <li>9. Foutcodegeheugen uitlezen en indien nodig wissen</li> <li>10. Gereed</li> </ol>

# 47 CHECK

# OPTION vehicle coding

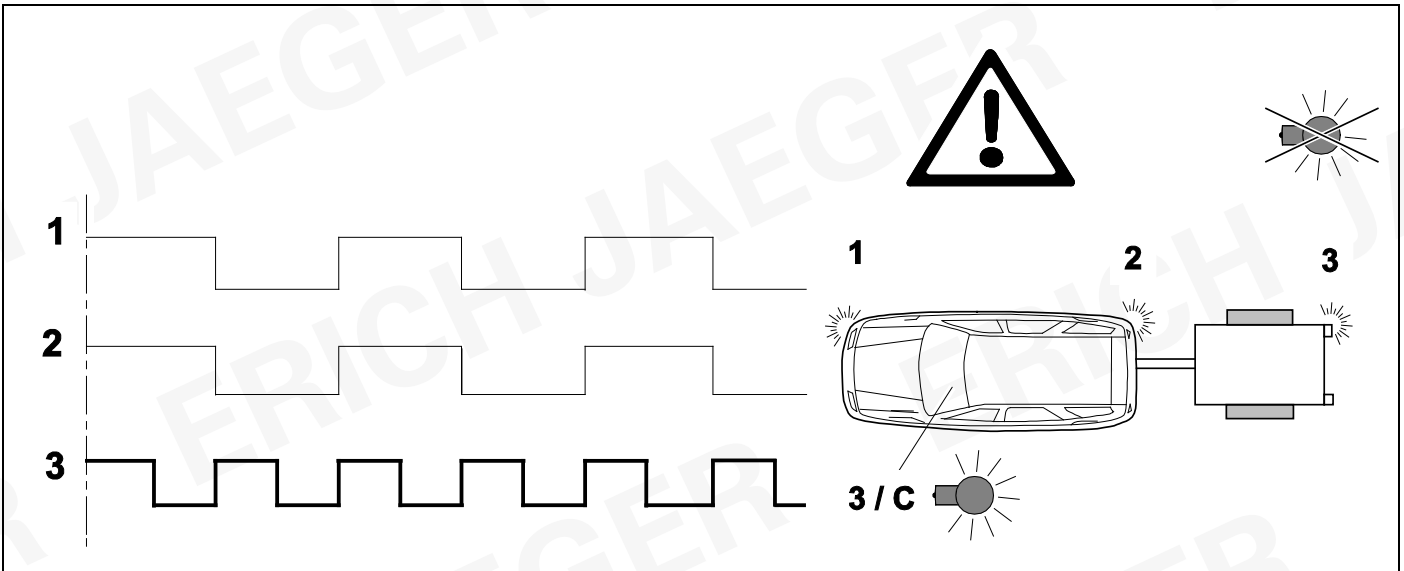

# 48

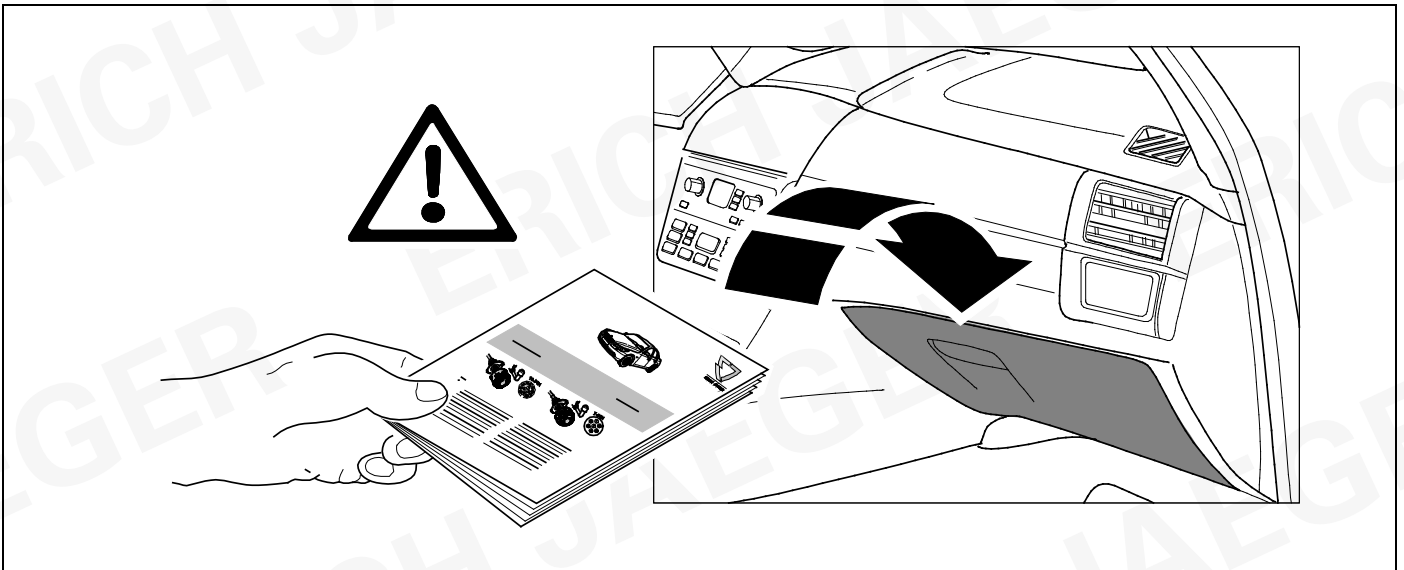

# 49

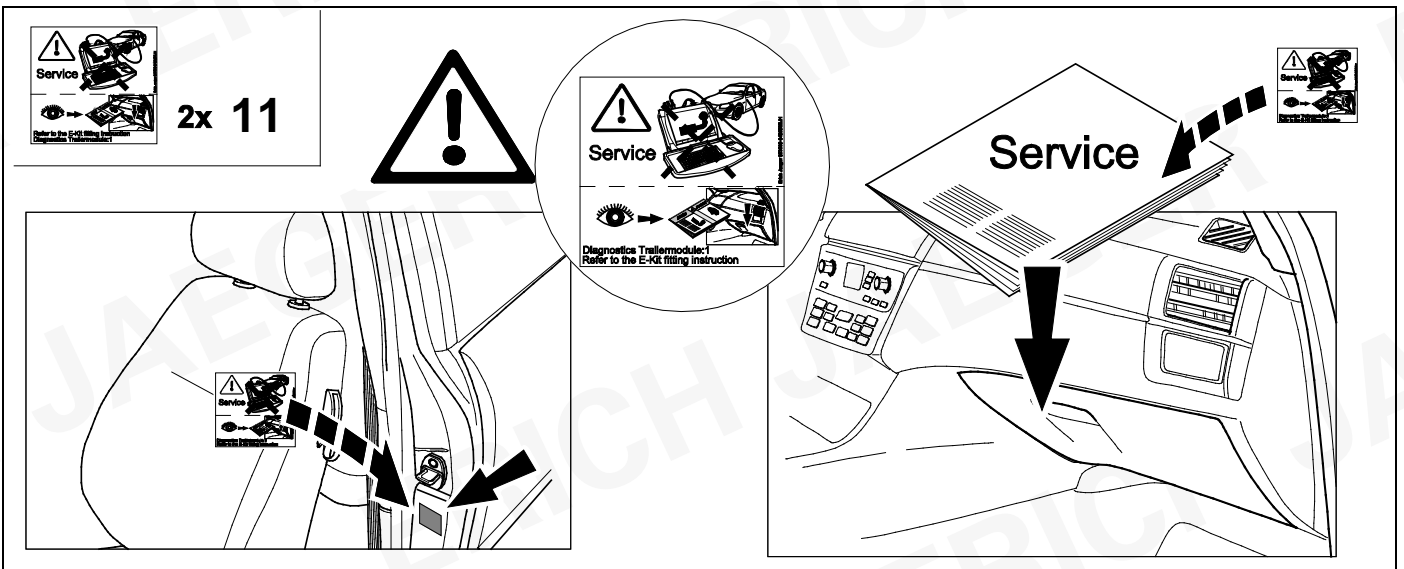

<b>D</b>	Änderungen bezüglich Konstruktion, Ausstattung Farbe sowie Irrtum vorbehalten. Angaben und Abbildungen unverbindlich	<b>PL</b>	Zastrzega się prawo do zmian dot. konstrukcji, wykończenia, kolorystyki oraz pomyłek. Dane i ilustracje niewiążące.
<b>GB</b>	Subject to change in terms of construction, equipment and colour, and may contain errors. The information and illustrations are non-binding.	<b>TR</b>	Tasarım, donanım ve renk bakımından değişiklik yapma hakkı ve hata ve eksiklik mahfuzdur. Veriler ve resimler bağlayıcı değildir.
<b>F</b>	Sous réserve de modifications de la construction, de l'équipement, de la couleur et sous réserve d'erreurs. Les indications et les illustrations sont sans engagement.	<b>H</b>	A szerkezet, a kivétel és a szín változtatása, valamint a változások joga fenntartva. Az adatok és az ábrák nem kötelező érvényűek.
<b>NL</b>	Wijzigingen met betrekking tot constructie, uitvoering en kleur evenals vergissingen voorbehouden. Gegevens en afbeeldingen niet bindend.	<b>HR</b>	Pravo promjena u svezi konstrukcije, opreme, boje kao i zabune oridžavamo. Podaci i ilustracije su neobavezne.
<b>DK</b>	Ændringer med hensyn til konstruktion, udstyr, farver samt fejl forbeholdes. Oplysninger og illustrationer er uforpligtende.	<b>BUL</b>	Запазени права по отношение на конструкцията, оборудването, цвета и грешки. Данните и изображенията не са обвързващи.
<b>N</b>	Ændringer angående konstruksjon, utstyr, farge og feiltagelse forbeholdes. Oplysninger og illustrasjoner uforbindtlig.	<b>RO</b>	Ne rezervăm dreptul unor modificări ale construcției, dotării, culorii și dreptul la erori Datele indicate și imaginile sunt orientative.
<b>S</b>	Med reservation för ändringar vad det gäller konstruktion, utrustning, färg samt för misstag. Uppgifterna och bilderna är inte bindande.	<b>RU</b>	Права на внесение изменений относительно конструкции, оснащения, окраски, а также на ошибки сохраняются. Данные и иллюстрации имеют примерный характер.
<b>FIN</b>	Pidätämme oikeuden rakennetta, varustusta, väriä koskeviin sekä erehdyksestä johtuviin muutoksiin. Tiedot ja kuvat eivät ole sitovia.	<b>LT</b>	Pasiliekaama konstrukcijos, įrangos bei reikmenų, spalvos pakeitimų ir klaidų teisė. Duomenys ir iliustracijos neįpareigojantys.
<b>I</b>	Con riserva di modifiche relative a progettazione, dotazione, colore ed errori. Le indicazioni e figure sono fornite senza impegno.	<b>LV</b>	Tiek paturētas tiesības uz konstrukcijas, iekārtu, krāsu izmaiņām, kā arī kļūdīšanās. Dati un attēli bez saistībām.
<b>E</b>	Reservadas las modificaciones respecto a diseño, equipamiento, color, así como error. Indicaciones y figuras sin compromiso.	<b>EST</b>	Konstruksiooni, varustuse ja võervi osas muudatused ning eksimine lubatud. Andmed ja joonised on mittesiduvad.
<b>P</b>	Reservamos o direito de alterações relativamente ao desenho, equipamento, cor, bem como de erro. Os dados e as gravuras não implicam compromisso da nossa parte.	<b>SLO</b>	Zadržana pravica do sprememb glede konstrukcije, opreme, barve ter pomote. Podatki in slike so neobvezne.
<b>GR</b>	Διατηρώνουμε κάθε επιφύλαξη ως προς αλλαγές σε σχέση με κατασκευή, εξοπλισμό, διαρρύθμιση, χρωματισμούς και λάθη παραδρομής.	<b>SK</b>	Zmeny, ktoré sa týkajú konštrukcie, vybavenia, farby, ako aj omyly sú vyhradené. Údaje a zobrazenia sú nezáväzné.
<b>CZ</b>	Změny, týkající se konstrukce, vybavení, barvy, jakož i omyly jsou vyhrazeny. Údaje a vyobrazení jsou nezávazné.		

**ERICH JAEGER Artikelnummer:**  
**ERICH JAEGER part number:**

**311069**

