

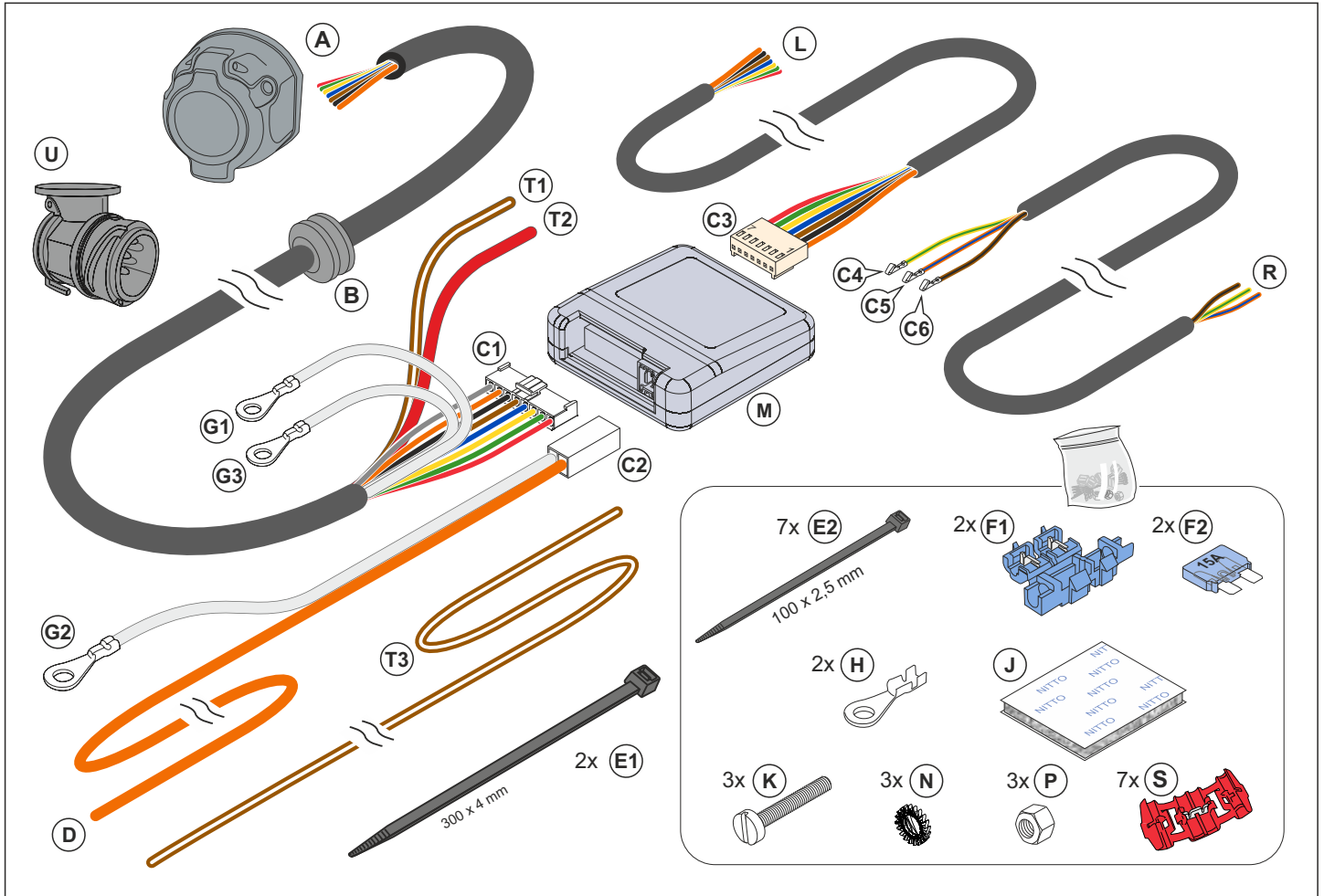

Universele elektrokit voor trekhaak  
 Faisceau universel pour attelage de remorque  
 Universelle Elektrosatz für Anhängerkupplung  
 Universal wiring kit for towbar  
 Kit elettrico universale per ganci di traino

Ref.: SETGDWSP13\_3



- NL** Montagehandleiding voor elektrokit met 13 pins stekker volgens DIN/ISO-norm 1724. Foutieve montage van de trekhaak of de uitvoering door een niet gekwalificeerd persoon zal automatisch leiden tot het vervallen van de garantie, het verlies van enig recht op schadevergoeding en de afloop van productaansprakelijkheid.
- FR** Notice de montage du faisceau électrique pour attelage de remorque avec prise 13 plots conforme à la Norme DIN/ISO 1724. Une mauvaise installation ou celle effectuée par personnel non qualifié signifie la perte de la garantie, tout droit à indemnisation et à l'expiration de toute responsabilité civile sur le produit.
- D** Einbauanleitung für Elektrosatz mit Steckdose mit 13-poligem Anschluß nach DIN/ISO Norm 1724. Unsachgemäße Montage oder Montage erfolgt durch ungeübten Personen führt automatisch zur Kündigung der Garantie, Verlust von jedes Recht auf Schadensersatzansprüche und Ablauf des Produkthaftung.
- GB** Fitting instructions of towbar wiring kit with 13 pins socket according to DIN/ISO Norm 1724. The improper assembly or the fitting done by an unskilled person will automatically result in cancellation of the guarantee, the loss of any right of indemnity and the expiration of all product liability.
- IT** Istruzioni per l'installazione del kit elettrico 13 poli a norma DIN/ISO 1724. L'assemblaggio inadeguato o eseguito da personale non qualificato significa la perdita della garanzia, qualsiasi diritto al risarcimento e alla scadenza di ogni responsabilità per il prodotto.

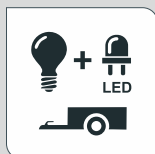
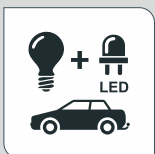

0

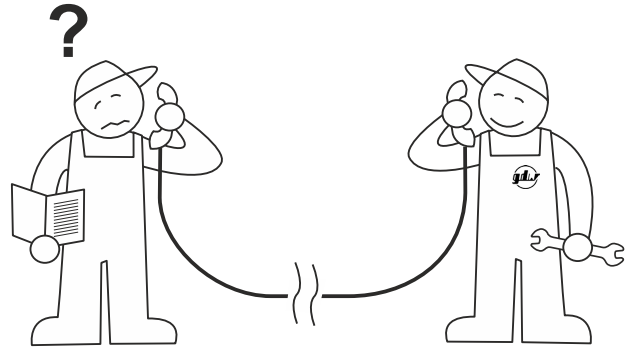
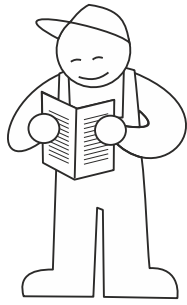

Tel.: (+32) 56 60 42 12  
helpdesk@gdwtowbars.com

Aansluiting van de stekkerdoos / Connexion de la prise / Anschluss von Steckdose / Socket connection / Connessione de la presa

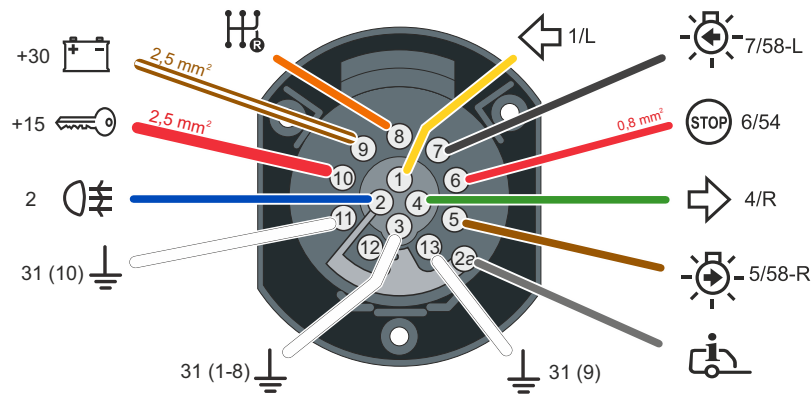

	NL	FR	D	GB	IT	
1	← 1/L	Linkerknipperlicht	Clignotant gauche	Linken Fahrtrichtungsanzeige	Left indicator	Freccia sinistra
2	☼ 2	Mistlicht	Antibrouillard	Nebelschlußlicht	Rear fog light	Retronebbia
2a	🚛 2a	Aanhangerdetectie	Détection de remorque	Anhängererkennung	Trailer detection	Ricosnocim. rimorchio
3	⏚ 31 (1-8)	Aarding (1-8)	Masse (1-8)	Masse (1-8)	Earth (1-8)	Massa (1-8)
4	→ 4/R	Rechterknipperlicht	Clignotant droit	Rechten Fahrtrichtungsanzeige	Right indicator	Freccia destra
5	🚗 5/58	Rechterachterlicht	Feu arrière droit	Rechten Rücklicht	Right tail light	Posizione destra
6	🛑 6/54	Remlicht	Feu de stop	Bremslicht	Brake light	Luce d'arresto
7	🚗 7/58	Linkerachterlicht	Feu arrière gauche	Linken Rücklicht	Left tail light	Posizione destra
8	🚗 8	Achteruit	Marche arrière	Rückwärtsgang	Reverse	Retromarcia
9	🔋 +30	Continue stroom	Courant continu	Permanentstrom	Permanent current	Positivo permanente
10	🔑 +15	Contactstroom	Courant à contact	Schalterstrom	Switch current	Positivo sottochiave
11	⏚ 31 (10)	Aarding (10)	Masse (10)	Masse (10)	Earth (10)	Massa (10)
12	--	--	--	--	--	--
13	⏚ 31 (9)	Aarding (9)	Masse (9)	Masse (9)	Earth (9)	Massa (9)

Info

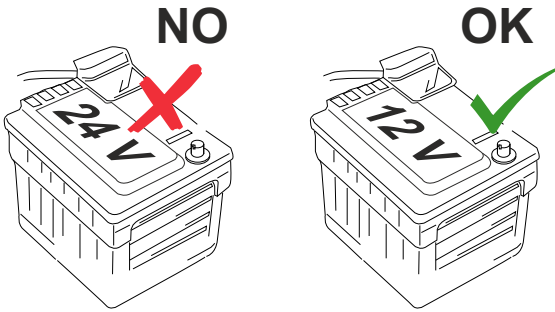

1

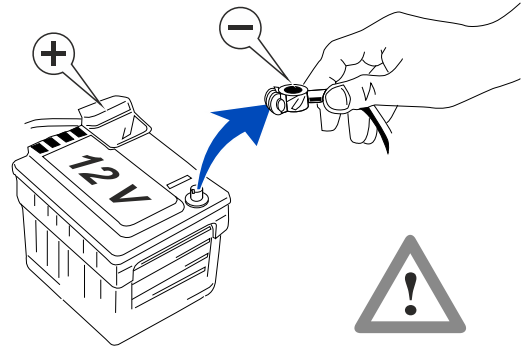

Code / Codice

2

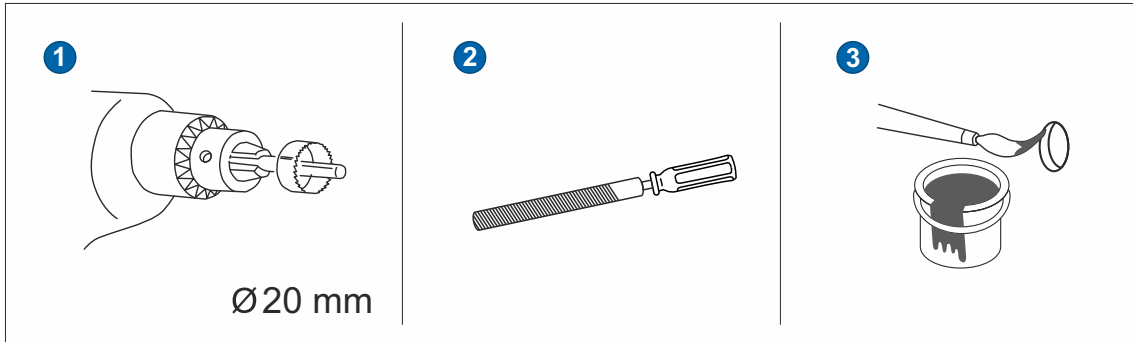

Ø20 mm

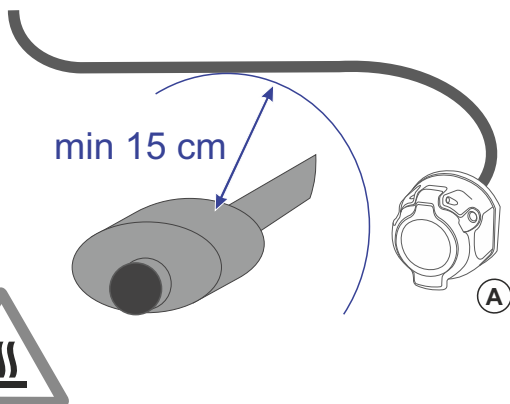
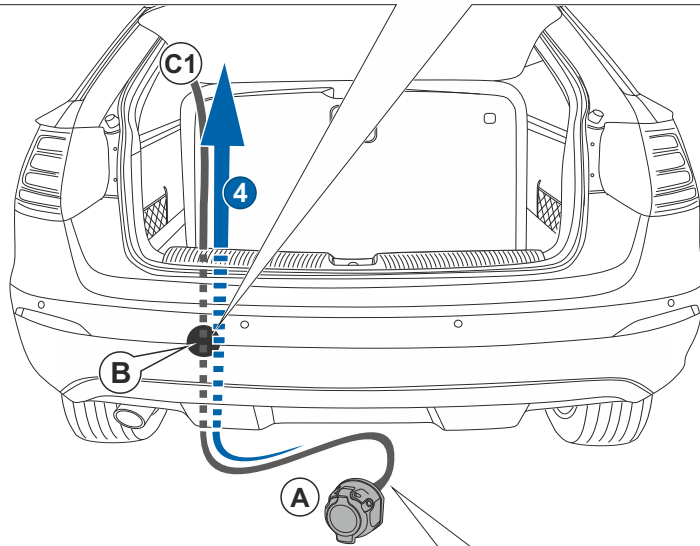

min 15 cm

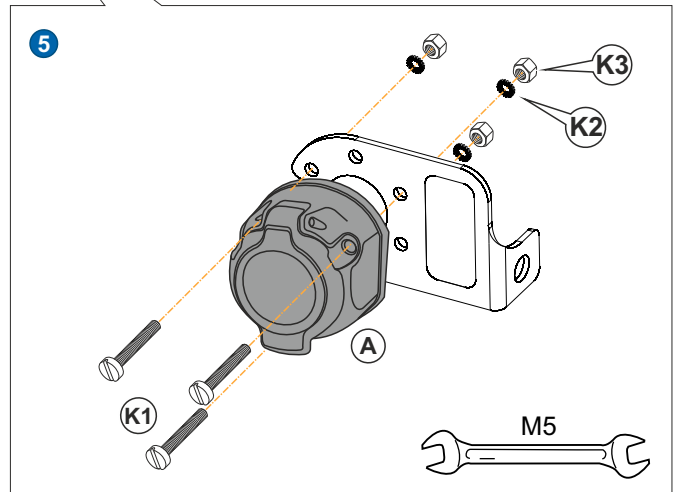

Info

- NL** Indien u extra kabellengte nodig heeft, bijvoorbeeld voor het rechterknipperlicht:
- FR** Si vous avez besoin d'un câble plus long, par exemple, pour le clignotant droit:
- D** Falls Sie zusätzlicher Kabellänge brauchen, zum Beispiel für das Rechten Fahrlichtanzeige:
- GB** In case you need extra wire length, for example, for the right indicator:
- IT** Se avete bisogno di un cavo più lungo, per esempio, per la freccia destra:

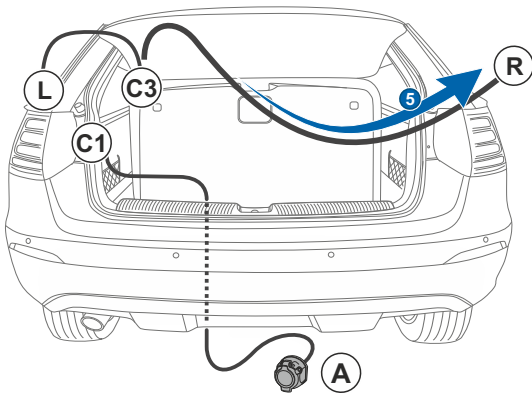
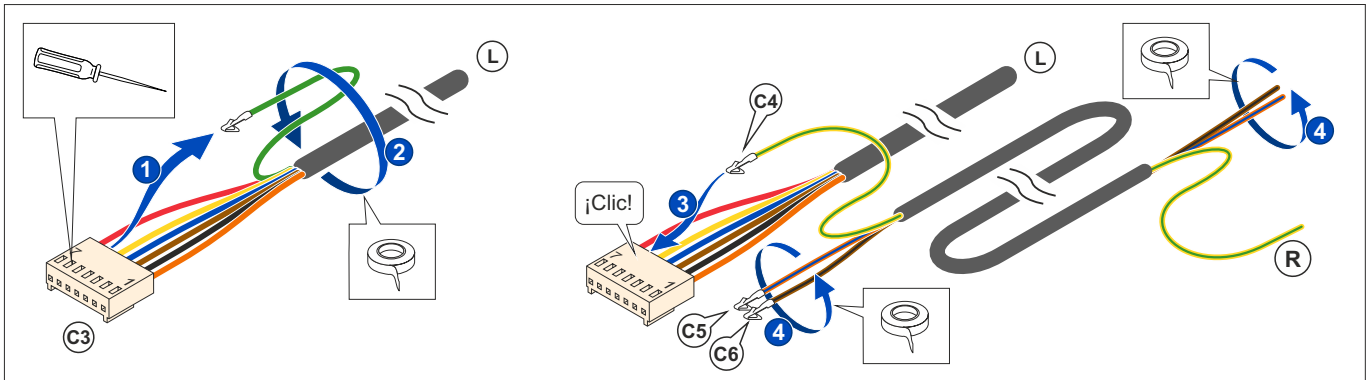
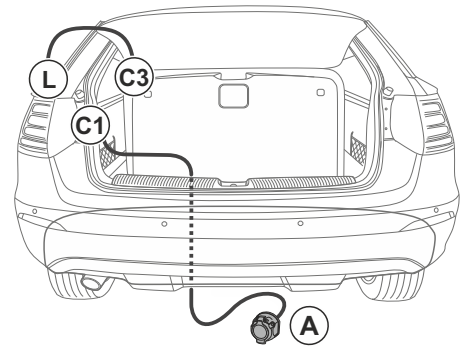

	6 ←	
	5 →	
	4 ⚡	
	1 ⚡	
	3 ⚡	
	2 ⚡	

3

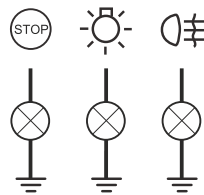
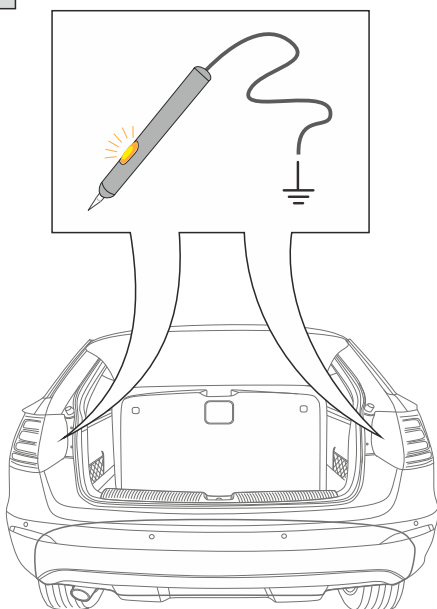

4 Standard

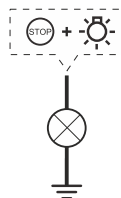

5 PWM

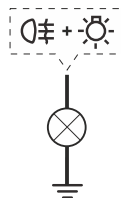

6 PWM

**4** Standard

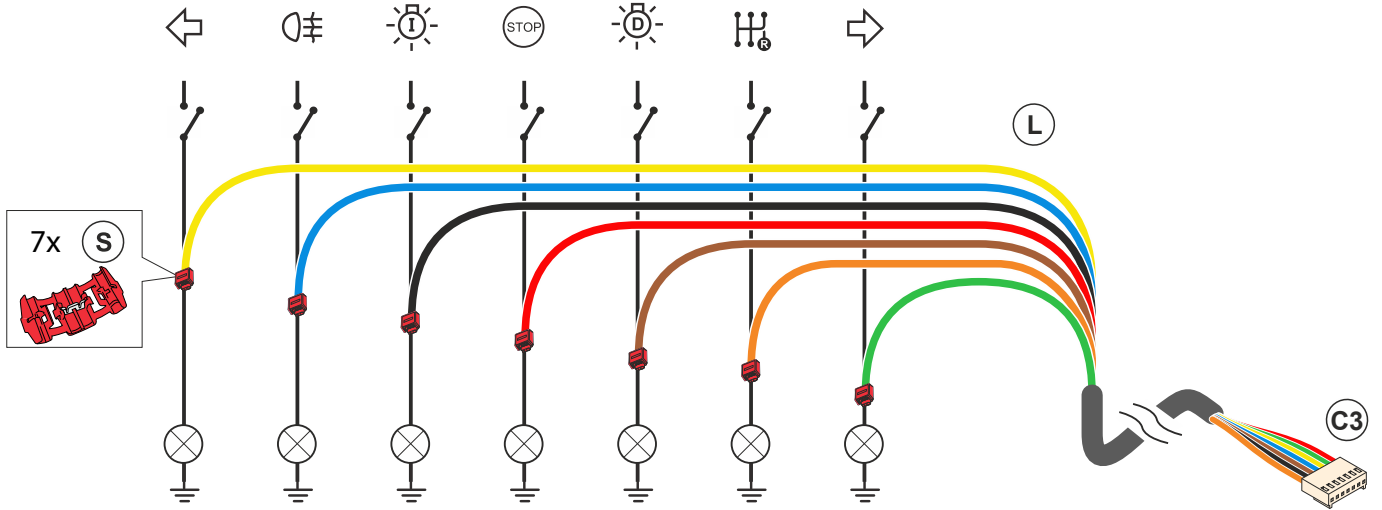

**5** Stop- en achterlicht / Stop et feu arrière / Brems- und Rücklicht / Stop & Tail / Stop e posizione

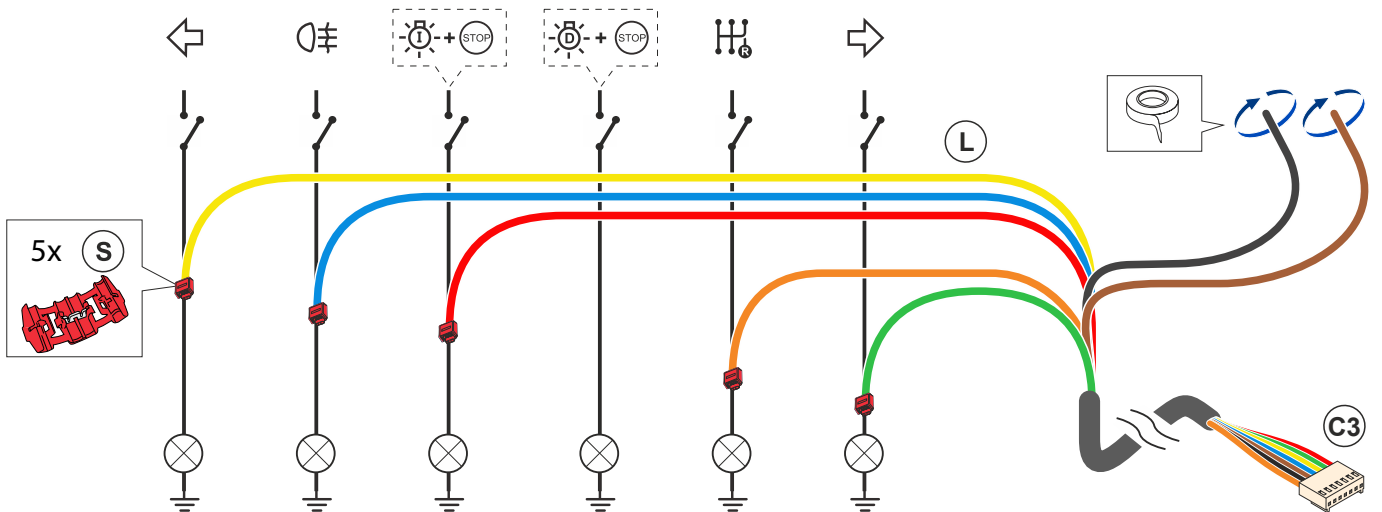

**6** Mist- en achterlicht / Antibrouillard et feu arrière / Nebelschluß- und Rücklicht / Fog & Tail / Retronebbia e posizione

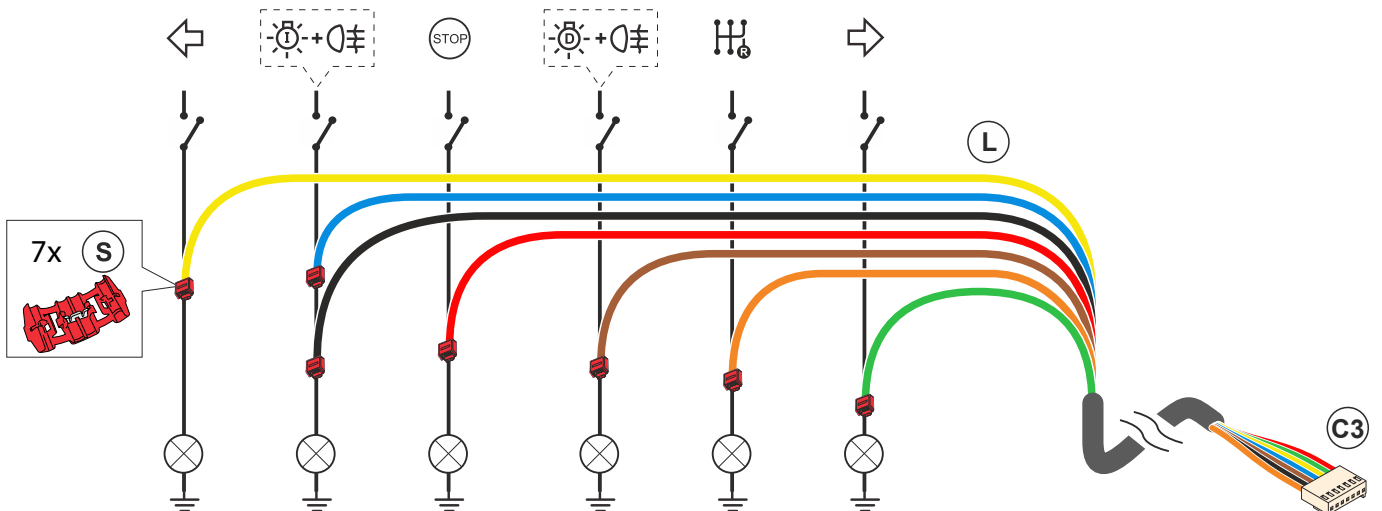

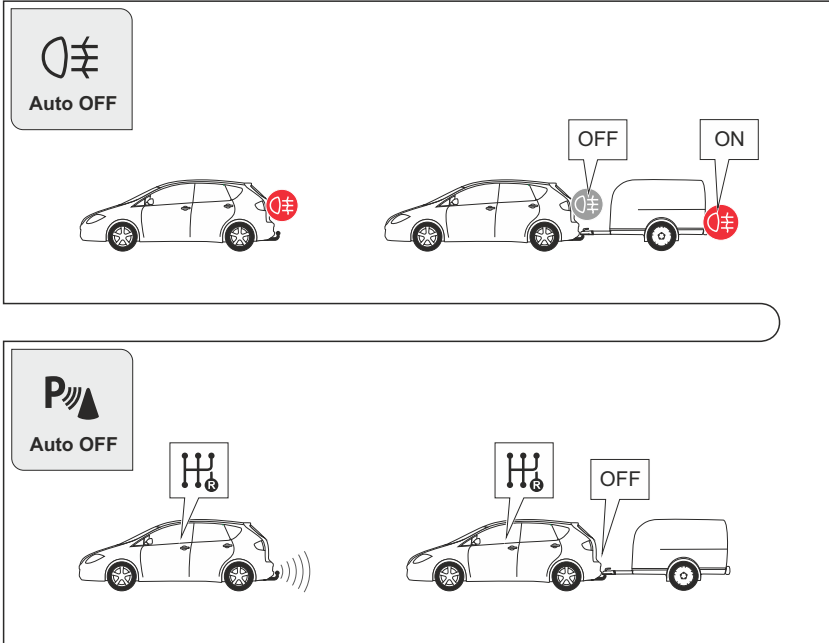

  
 Uitbreidingskit  
 Kit d'extension  
 Erweiterungssatz  
 Extension kit  
 Kit di estensione

Ref. / Part Nr.:  
**SETGDWSP\_3 PDC**

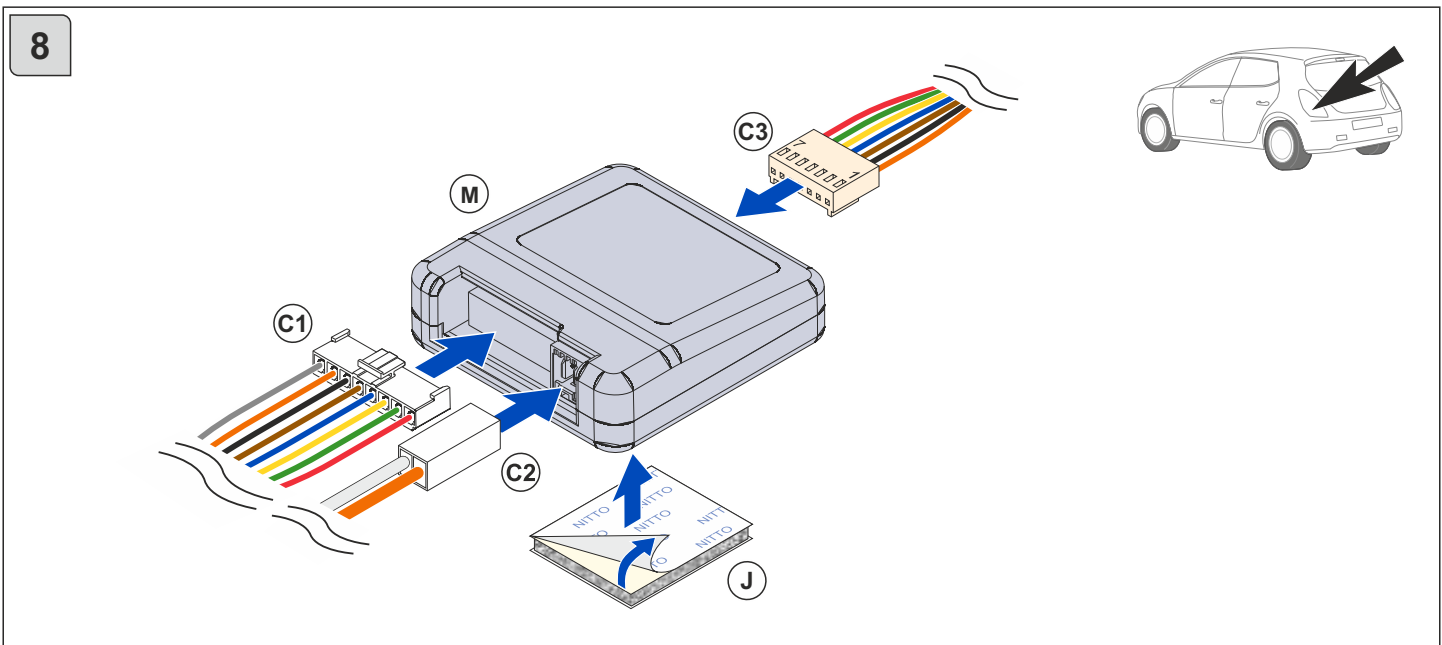
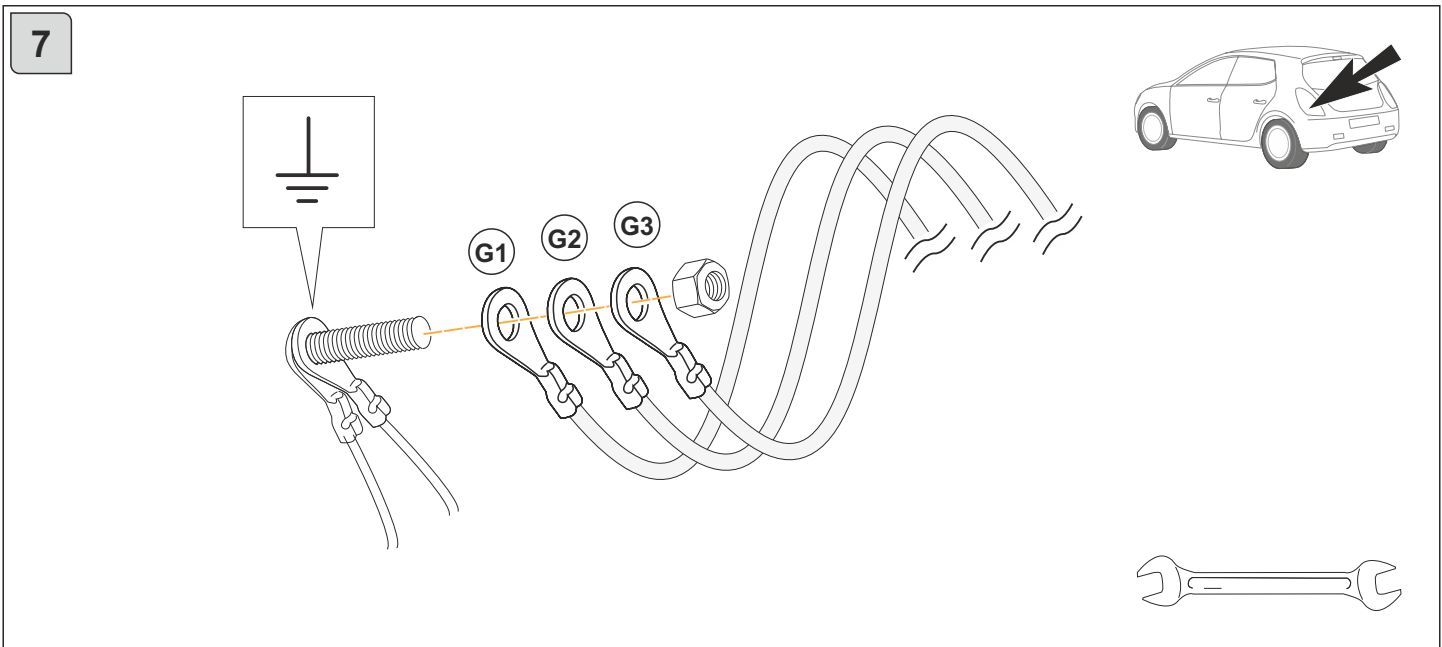

9

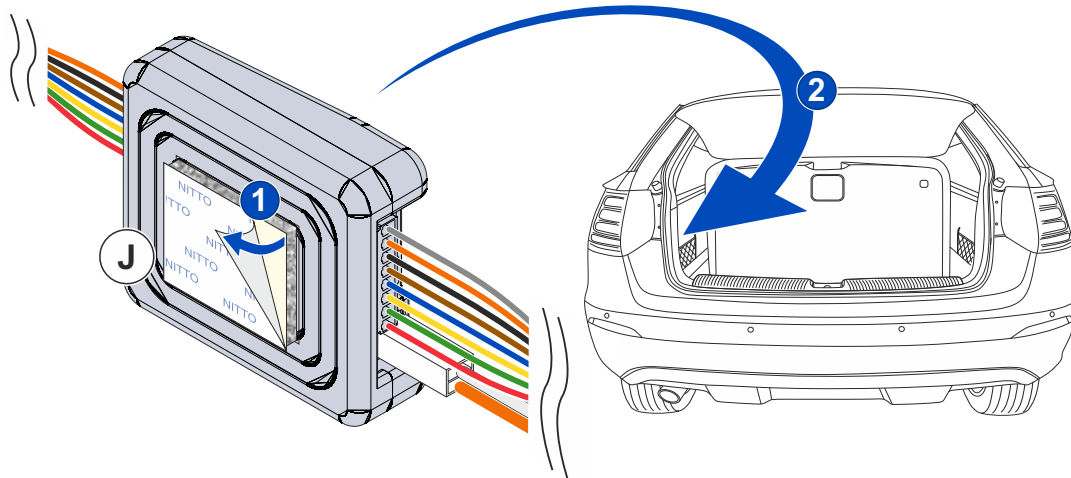

10

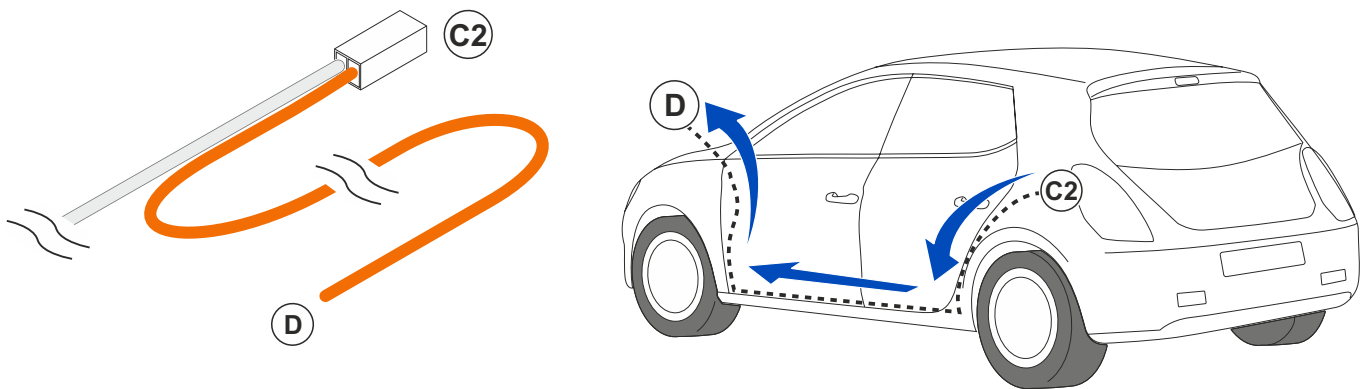

11

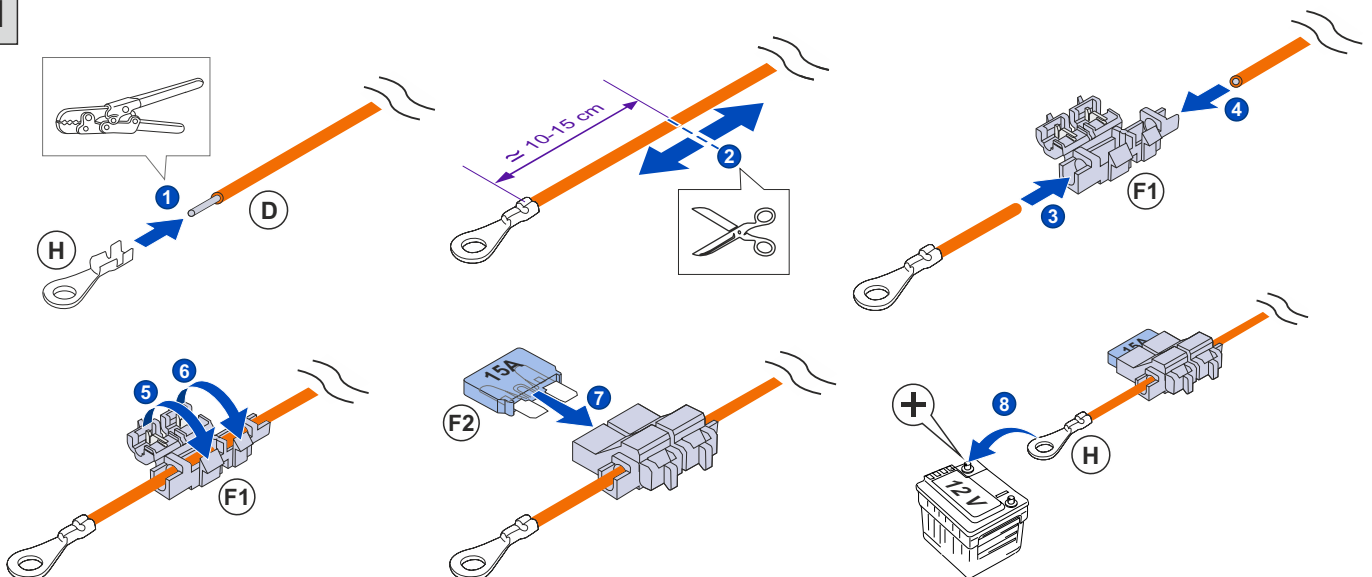



13

Continue stroom  
Contactstroom

Courant continu  
Courant à contacte

Permanenstroom  
Schalterstrom

Permanent current  
Switch current

Positivo permanente  
Positivo soochiave

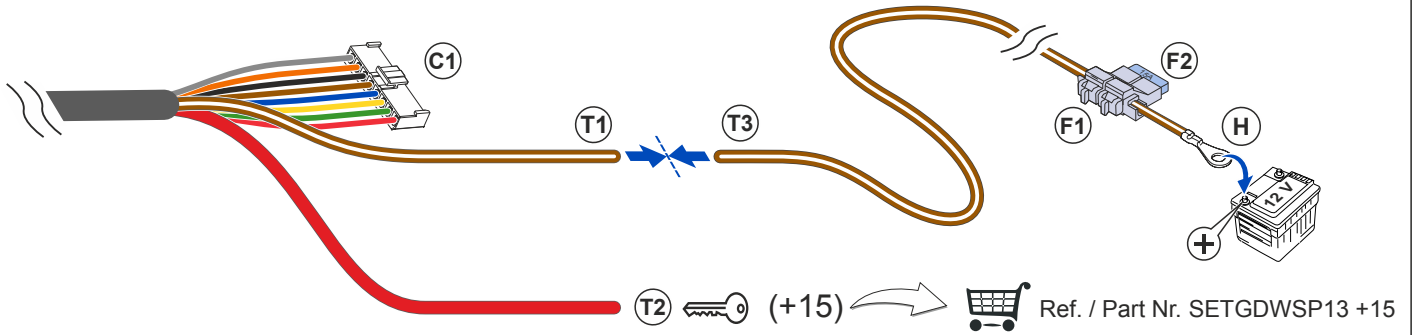

14

Laatste stappen / Dernières étapes / Letzten Schritte / Last steps / Ultimi passi

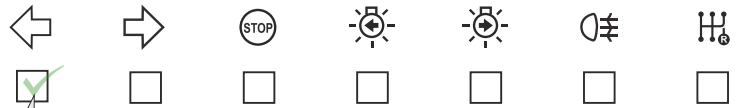
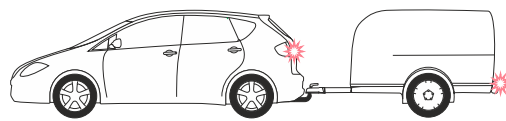
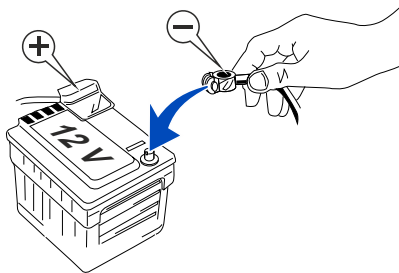

NO!

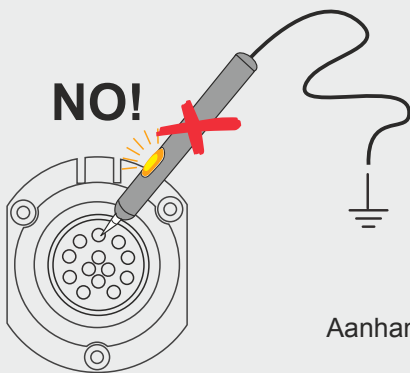

OK

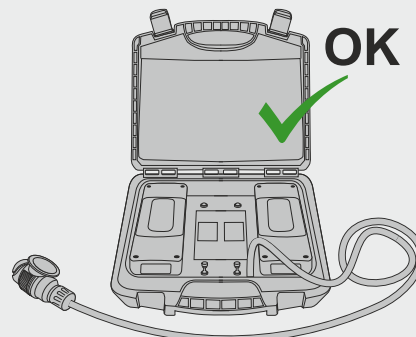

Aanhangersimulator / Simulateur d'une remorque / Anhängersimulator / Trailer simulator / Simulatore rimorchio

Ref. / Part Nr. TESTBOX

Control  
C2

