

NOTICE DE MONTAGE ATTELAGE
FORD MONDEO BREAK
 Depuis 2002

N° CE : e11*94/20*3426*00



BOISNIER SAS

REF.: 05192

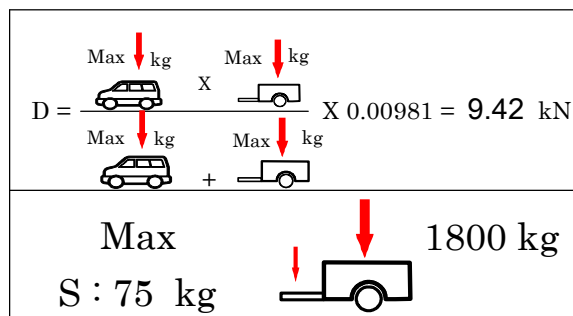

REF.: 05192

Démontage pare chocs :

OUI

Découpe :

OUI

Trous à réaliser :

NON

Découpe visible :

- Déposer le carter inférieur et le protecteur thermique du pot.
- Déposer le pare chocs (2 écrous dessous 2+2 vis à l'intérieur des ailes sous les bavette).
- Introduire les bras droit et gauche sous le véhicule et les solidariser avec les longerons au moyen de la visserie fournie conformément au schéma ci contre sans bloquer.
- Solidariser la ferrure avec les bras au moyen de la visseri fournie.
- Bloquer l'ensemble.
- Remonter le pare chocs après avoir pratiquer la découpe selon schéma.

Visserie identique
à côté droit

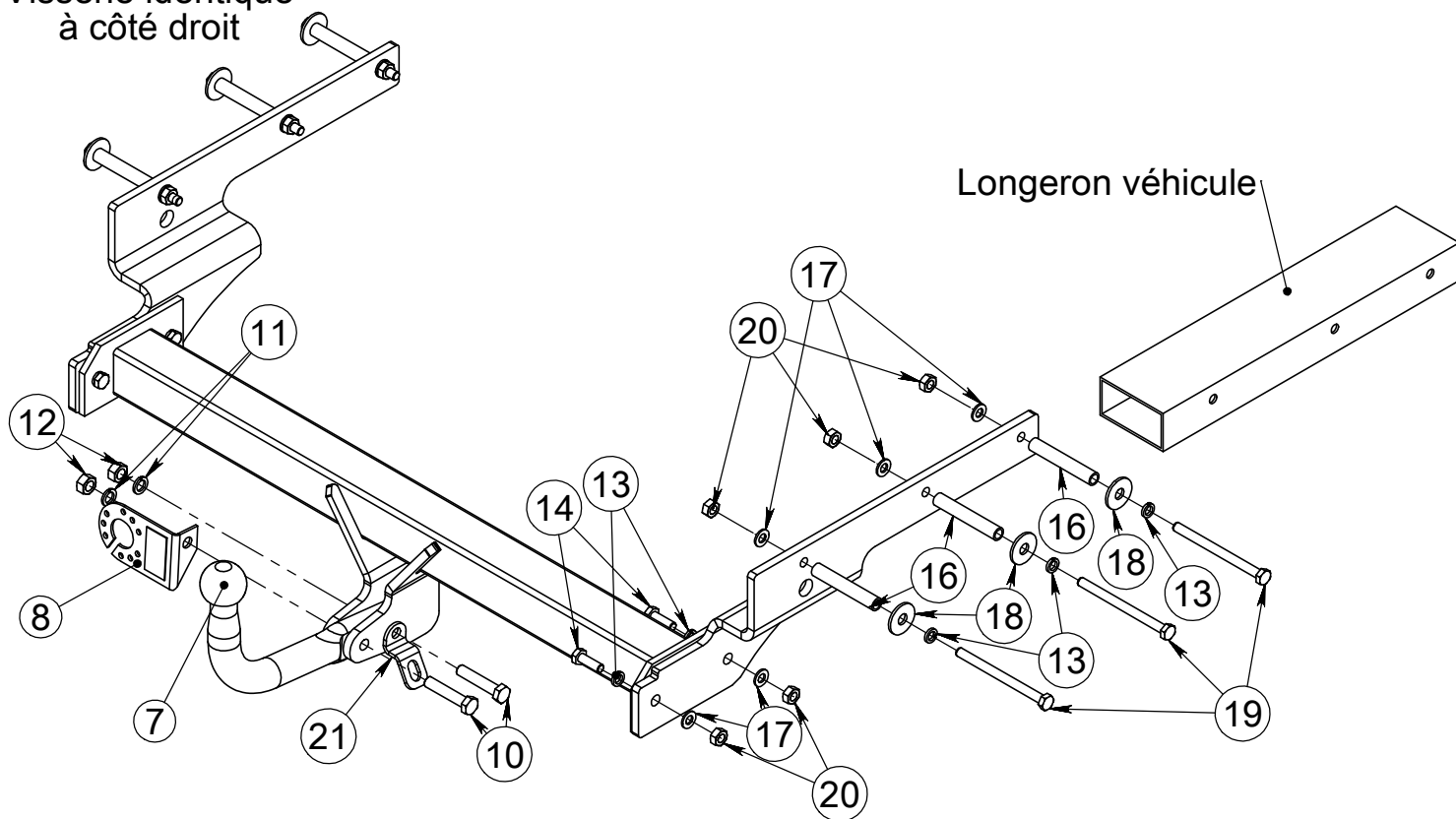



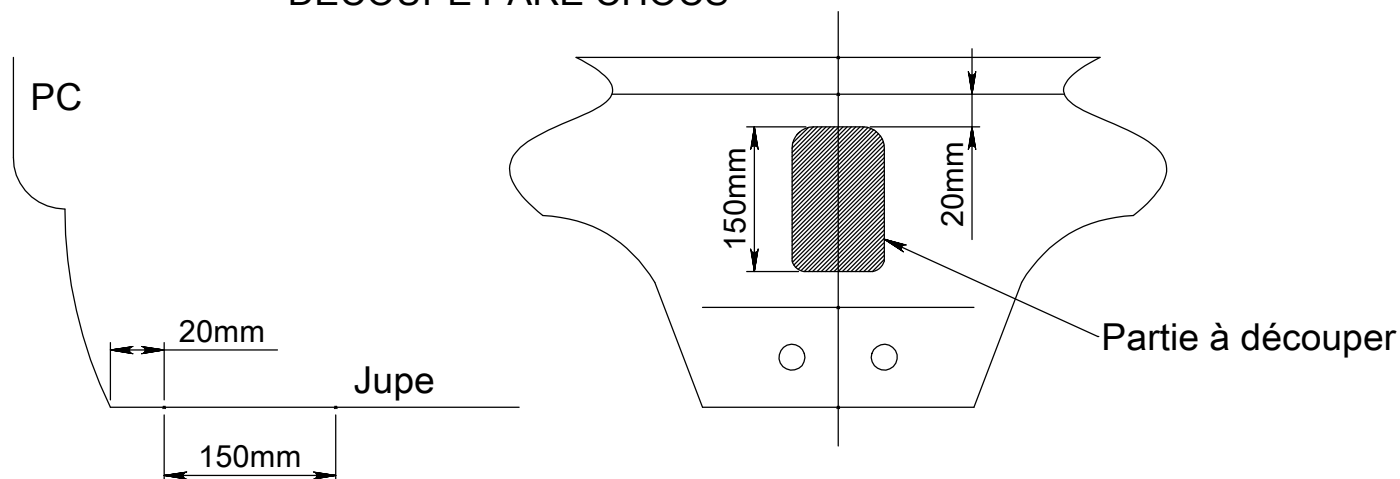



DECOUPE PARE CHOCS

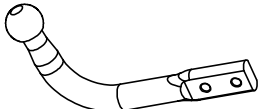
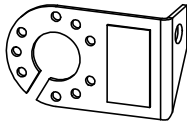
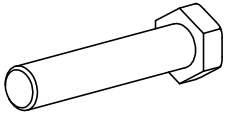

FORD MONDEO BREAK

Depuis 2002

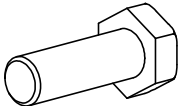
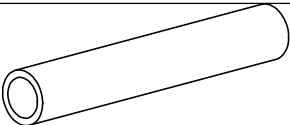
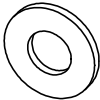
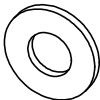
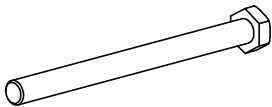
REF.: 05192

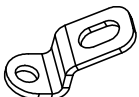
Schéma	Rep.	Qté.	DESIGNATION	CODE
	7	1	COL DE CYGNE 260/22	001026
	8	1	SUPPORT PRISE PLIEE	PRISE PLIEE
	10	2	vis DIN 931 M12x60 zn	700.00.12060
	11	2	rondelle GROWER M12 DIN128A zn	700.20.12
	12	2	écrou H DIN 934 M12	700.22.12
	13	10	rondelle GROWER M10 DIN128A zn	700.20.10
	14	4	vis EF DIN 933 M10x30 zn	700.03.10030
	16	6	Entretoise 11x15x92	950033
	17	10	rondelle 10,5x20x2 DIN125A	700.34.10520020
	18	6	rondelle 13x37x3 Din 9021	722.10.13037030
	19	6	vis DIN 931 M10x130 zn	700.00.10130
	20	10	écrou H DIN 934 M10	700.22.10
	21	1	ANNEAU DE SECURITE	958000

