



NOTICE DE MONTAGE ATTELAGE

RENAULT LAGUNA 3
BREAK ESTATE

N° CE : e11*94/20*6772*00



BOISNIER SAS

REF.: 04194

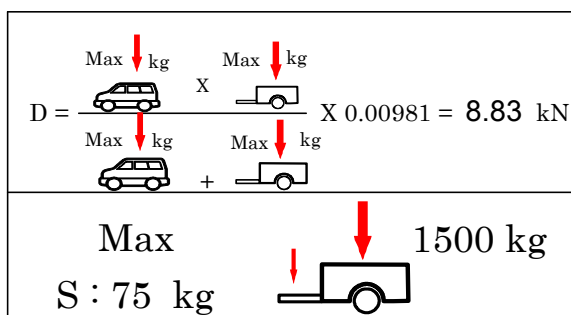

REF.: 04194

Démontage pare chocs :
Trous à réaliser :

NON
NON

Découpe :
Découpe visible :

NON
NON

- Déposer le carter plastique.
- Retirer les bouchons des trous de fixations dans les longerons.
- Présenter et assembler sans serrer les bras droit et gauche avec la visserie fournie conformément au schéma ci dessous.
- Présenter et assembler sans serrer la traverse sur les bras avec la visserie fournie.
- Bloquer toute la visserie (voir tableau des couples de serrage).
- Faire la découpe du carter plastique (voir schéma) et remonter celui-ci.

Avant découpe

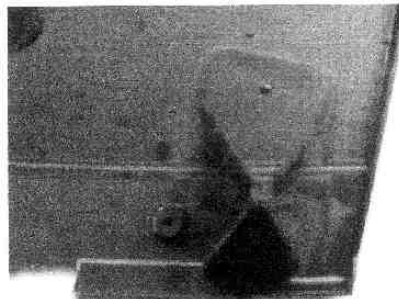

Après découpe

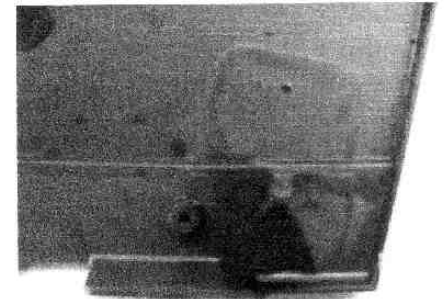

Supprimer les 4 renforts en étoile



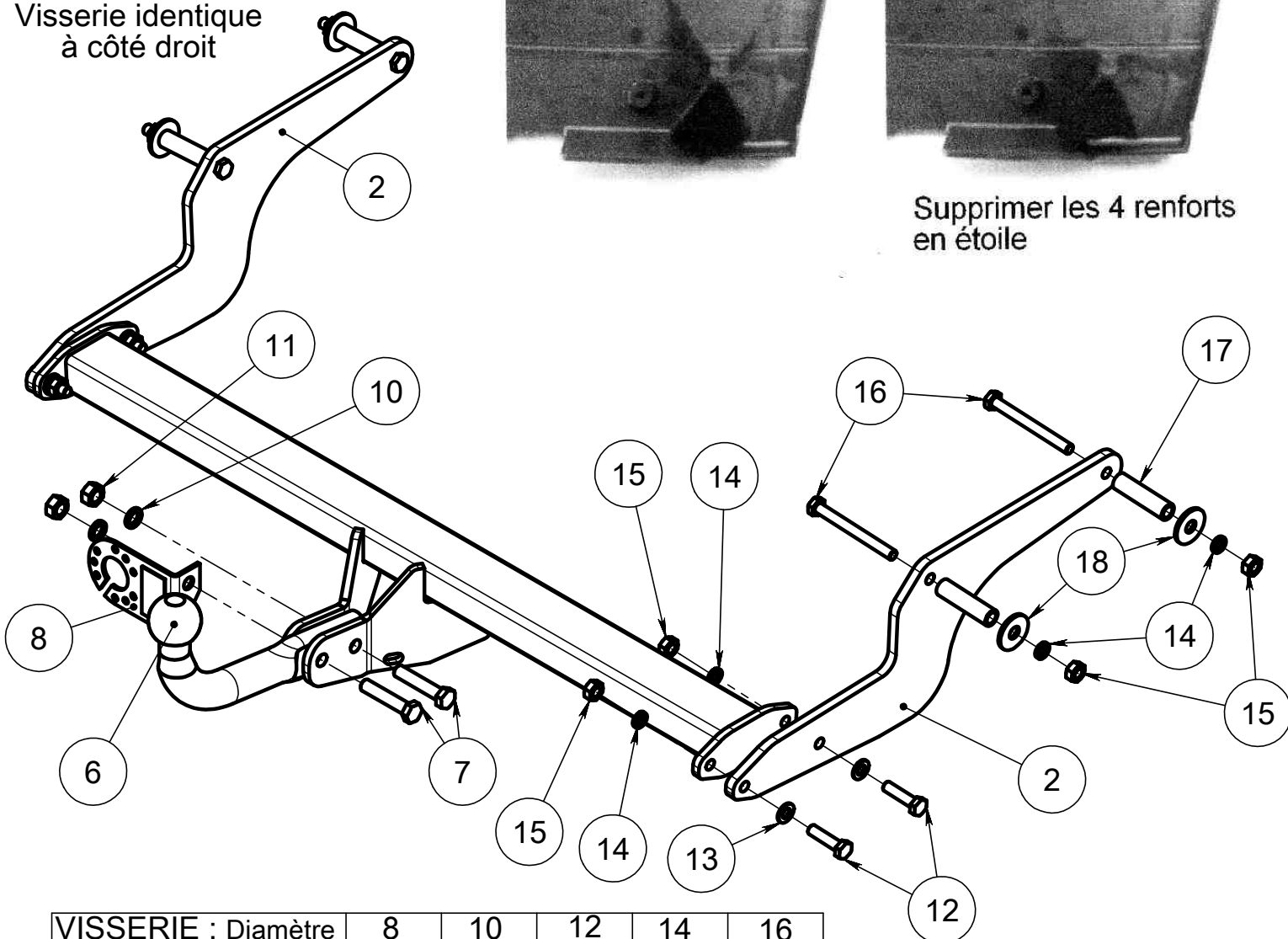





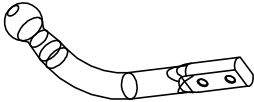
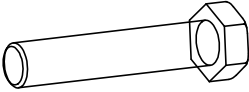

Visserie identique à côté droit

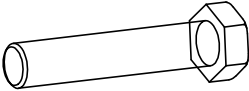

VISSERIE : Diamètre	8	10	12	14	16
Couple de serrage C.L 8.8 daN.m	2.3	4.5	8.0	13.0	19.0
C.L 10.9 daN.m	3.2	6.5	11.0	17.5	27.0

RENAULT LAGUNA 3 BREAK ESTATE

REF.: 04194

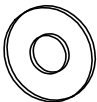
Schéma	Rep.	Qté.	DESIGNATION	CODE
	2	2	BRAS DROIT ET GAUCHE	0419440
	6	1	COL DE CYGNE 240/22	001024
	7	2	vis DIN 931 M12x60 zn	700.00.12060
	8	1	SUPPORT PRISE PLIEE	PRISE PLIEE
	10	2	rondelle GROWER M12 DIN128A zn	700.20.12
	11	2	écrou H DIN 934 M12	700.22.12
	12	4	vis EF DIN 933 M10x40 zn	700.03.10040
	13	4	rondelle 10,5x20x2 DIN125A	700.34.10520020
	14	8	rondelle GROWER M10 DIN128A zn	700.20.10
	15	8	écrou H DIN 934 M10	700.22.10
	16	4	vis DIN 931 M10x100 zn	700.00.10100
	17	4	Entretoise 12x17x65	950055
	18	4	rondelle 13x37x3 Din 9021	722.10.13037030

