



# NOTICE DE MONTAGE ATTELAGE RENAULT TWINGO 2

N° CE : e11\*94/20\*6734\*00



## BOISNIER SAS

REF.: 04190

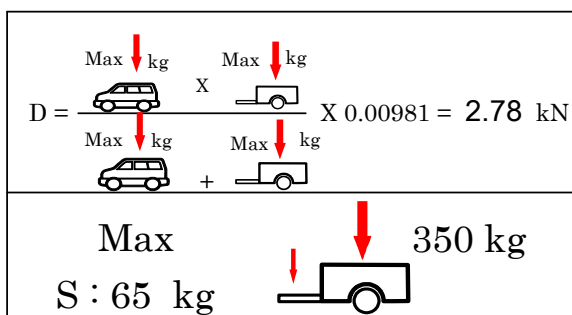

REF.: 04190

Démontage pare chocs :  
Trous à réaliser :

NON
NON

Découpe :

OUI
NON

Découpe visible :

- Déposer les vis situées sous le pare chocs.
- Dégager les zones de fixation des mastiques de protection.
- Faire la découpe du pare chocs conformément au schéma ci contre.
- Assembler sans serrer l'attelage avec la visserie fournie conformemnt au schéma ci contre.
- Bloquer la visserie (voir tableau des couples de serrage).
- Remettre les 3 vis du pare chocs.

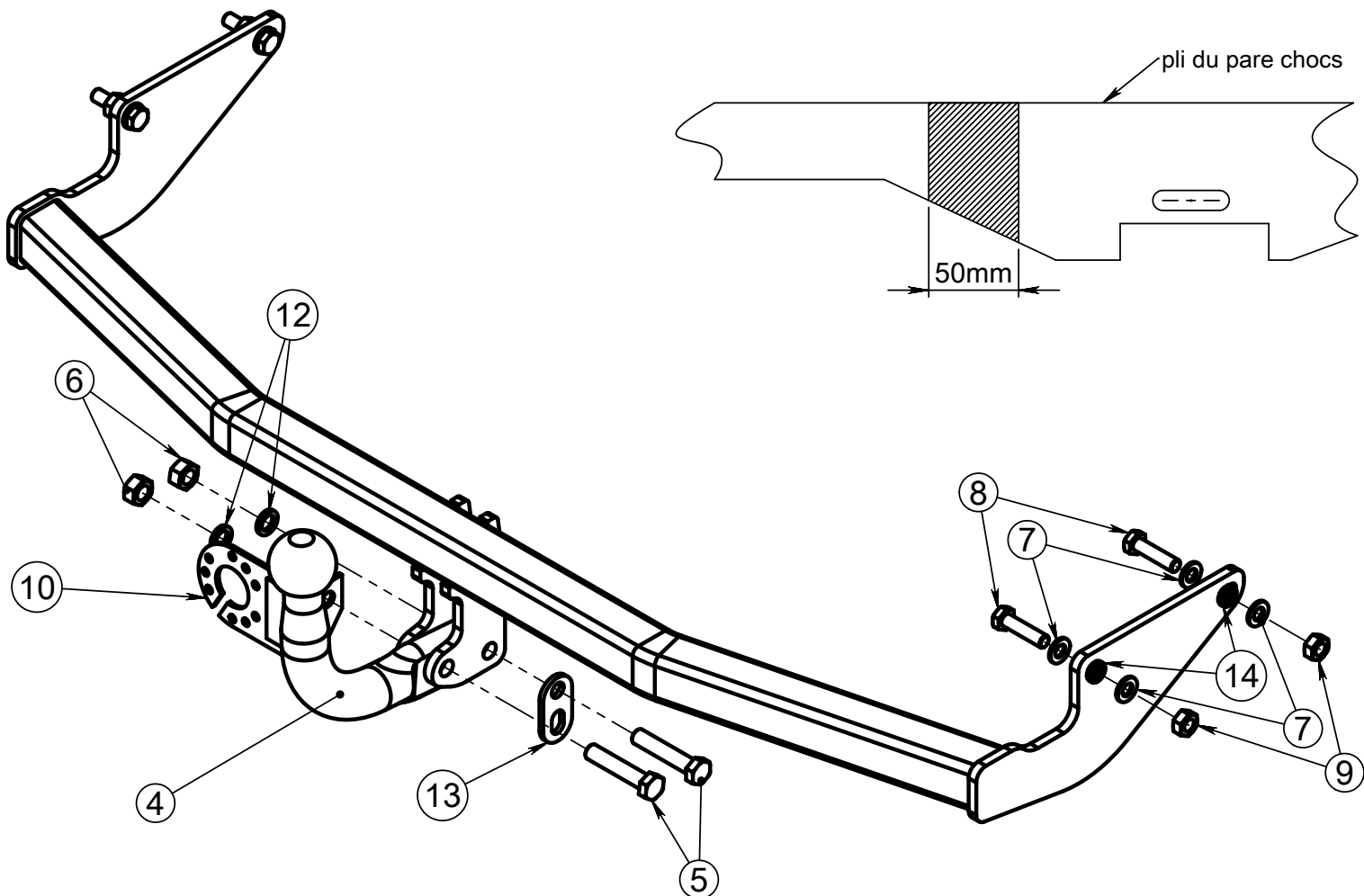

Visserie identique  
à côté droit

## DECOUPE PARE CHOCS

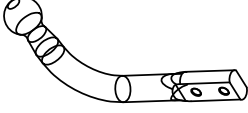
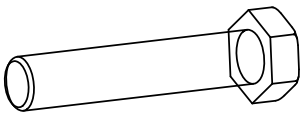
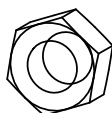
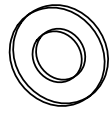
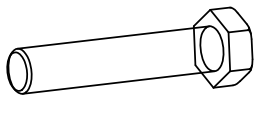
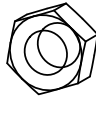
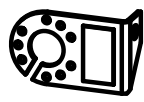
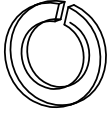
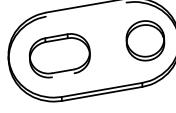

VISSERIE : Diamètre	8	10	12	14	16
Couple de serrage daN.m C.L 8.8	2.3	4.5	8.0	13.0	19.0
Couple de serrage daN.m C.L 10.9	3.2	6.5	11.0	17.5	27.0

REF.: 04190

Schéma	Rep.	Qté.	DESIGNATION	CODE
	4	1	ROTULE COL DE CYGNE	001020
	5	2	vis DIN 931 M12x60 zn	700.00.12060
	6	2	écrou H DIN 934 M12	700.22.12
	7	8	rondelle 10,5x20x2 DIN125A	700.34.10520020
	8	4	vis EF DIN 933 M10x40 zn	700.03.10040
	9	4	écrou H DIN 934 M10	700.22.10
	10	1	Support prise pliée	PRISE PLIEE
	12	2	rondelle GROWER M12 DIN128A zn	700.20.12
	13	1	ANNEAU DE SECURITE	958000
	14	4	rondelle GROWER M10 DIN128A zn	700.20.10

