

NOTICE DE MONTAGE ATTELAGE

PEUGEOT 207 SW

N° CE : e11*94/20* 6756.00*



BOISNIER SAS

REF.: 02118



$$D = \frac{\begin{array}{c} \text{Max} \downarrow \text{kg} \\ \text{Car} \end{array} \times \begin{array}{c} \text{Max} \downarrow \text{kg} \\ \text{Trailer} \end{array}}{\begin{array}{c} \text{Max} \downarrow \text{kg} \\ \text{Car} \end{array} + \begin{array}{c} \text{Max} \downarrow \text{kg} \\ \text{Trailer} \end{array}} \times 0.00981 = 6.84 \text{ kN}$$

Max \downarrow 1150 kg

S : 46 kg \downarrow 

- Déposer le pare chocs (4 vis + 2 clips dessous, 1 clips sous chaque aile).
- Déposer les sabots plastiques (2 clips et 1 écrou papillon).
- Découvrir les logements des écrous cages sur les faces externes des longerons et le taraudage sur la face intérieure.
- Positionner et fixer sans serrer l'attelage avec la visserie fournie conformément au schéma ci-contre.
- Bloquer toute la visserie (voir tableau des couples de serrage).
- Remonter les éléments précédemment démontés.

Découpe pare-chocs pour 207 SW Outdoor

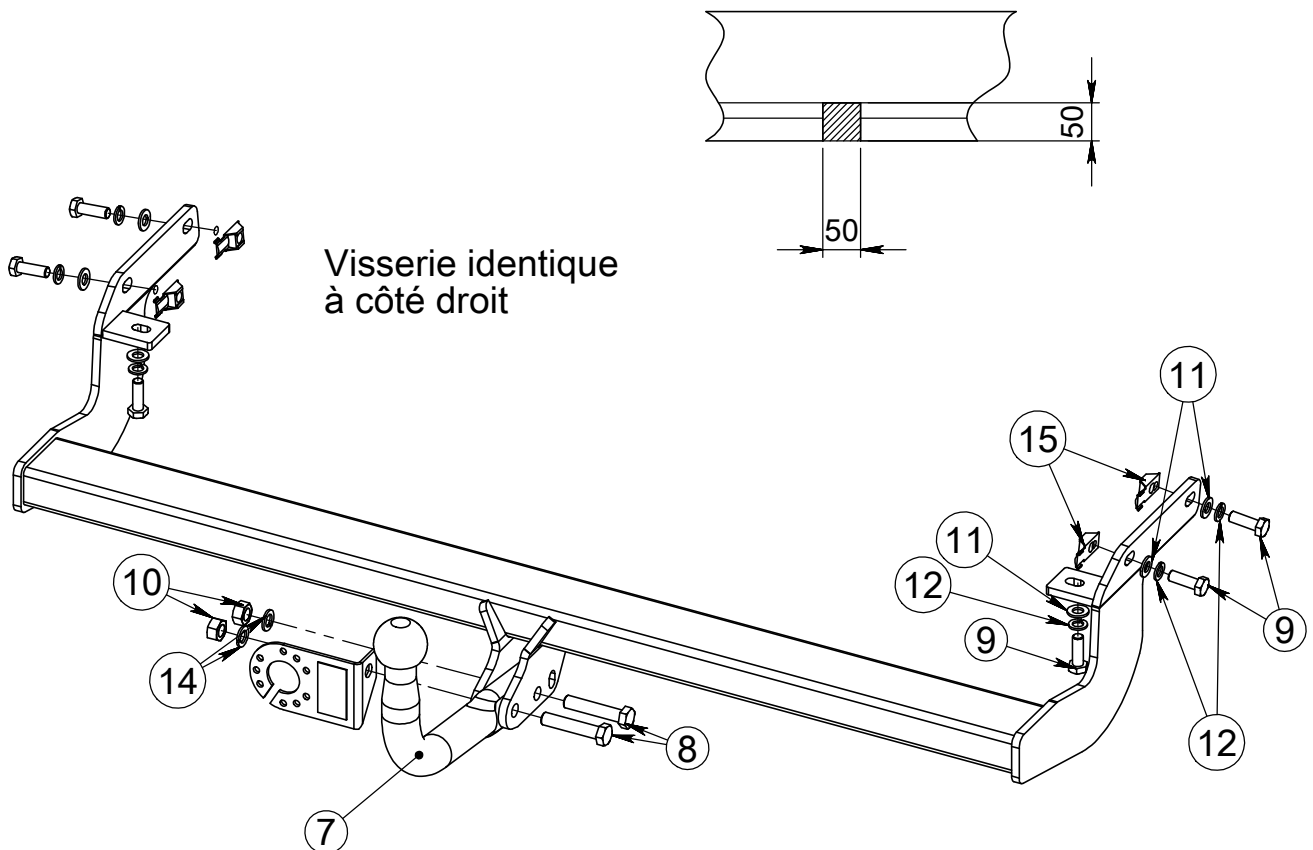





VISSERIE : Diamètre	8	10	12	14	16
Couple de serrage daN.m	C.L 8.8 2.3	4.5	8.0	13.0	19.0
	C.L 10.9 3.2	6.5	11.0	17.5	27.0

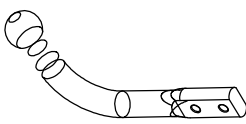

PEUGEOT

207 SW

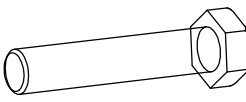
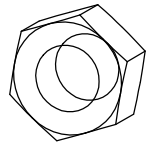
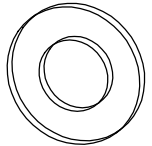
REF.: 02118

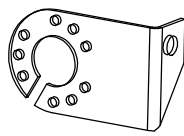
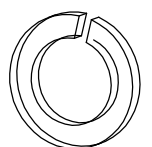
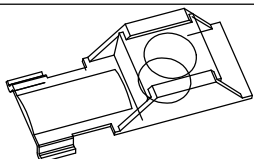
Schéma	Rep.	Qté.	DESIGNATION	CODE
	7	1	COL DE CYGNE 260/22 TOWING BALL 260/22	001026
	8	2	vis / screw DIN 931 M12x60 zn	700.00.12060
	9	6	vis / screw EF DIN 933 M10x30 zn	700.03.10030
	10	2	écrou / nut H DIN 934 M12	700.22.12
	11	6	Rondelle / washers 10,5x20x2 DIN 125A	700.34.10520020
	12	6	rondelle / washers grower M10 DIN 128A zn	700.20.10
	13	1	PRISE PLIEE / TRAILER SOCKET HOLDER	PRISE PLIEE
	14	2	rondelle / washers grower M12 DIN128A zn	700.20.12
	15	4	Ecrou cage / Cage nut M10 44x23	775.00.04

